

ROCHESTER INSTITUTE OF TECHNOLOGY

**A Thesis Submitted to the Faculty of
The College of Fine and Applied Arts
in Candidacy for the Degree of
MASTERS OF FINE ARTS**

The Aqua-Dock

A portable, submergible scuba diving platform

BY

Louis Iannone

Date: 10-22-92

APPROVALS

Advisor: James Sias

Date: 11/12/92

Associate Advisor: Robert Kahute:

Date: 11/17/92

Associate Advisor: Paul Hoogesteger:

Date: 12/2/92

Special Assistant to the Dean of Graduate Affairs: Philip Bonarth

Date: 1/27/93

Dean, College of Imaging Arts and Sciences: Dr. Margaret O. Lucas

Date: 2-2-93

I, Louis Iannone, hereby grant permission to the Wallace Memorial Library of RIT to reproduce my thesis in whole or in part. Any reproduction will not be for commercial use or profit.

Date: _____



ACKNOWLEDGEMENTS

I would like to thank all those who helped me physically, financially, emotionally and in an advisory manner. Without you this thesis would not exist.



TABLE OF CONTENTS

PROPOSAL

CONCEPTION AND RATIONALE	1
RESEARCH	2
DESIGN PARAMETERS AND OBJECTIVES	3
INITIAL DESIGN PROBLEMS	8

PROJECT

PROCESS	9
POWER SOURCE	10
PERIMETER (FLOAT)	12
EQUATIONS	13
CENTER SUPPORT	16
CONTROLS / VALVING	20
LEGS	23
PLATFORM BASE	24
MISCELLANEOUS	26
EVALUATION	27

APPLICATION

APPLICATION OF DESIGN (PRODUCT DEVELOPMENT CONCEPTS)	31
ALTERNATIVE DESIGNS	38
CONCLUSION	43

BIBLIOGRAPHY	44
--------------------	----

APPENDIX I COLOR IMAGES	45
----------------------------------	----

APPENDIX II CONCEPTION AND FORMATION OF DESIGN	52
---	----

APPENDIX III COMPUTER AIDED DESIGN	60
---	----



PROPOSAL

CONCEPTION AND RATIONALE

The Aqua-Dock is a portable, submergible scuba diving platform. It is a floating dock that can be submerged to the sea floor and brought back to the surface.

The initial purpose of the Aqua-Dock is to give student divers a base to work off of and a reference point both above and below the surface during open water dives. Any platform that is currently used by instructors is bolted permanently to the sea bed. As dive sites are constantly changing and expanding, fixed platforms become less used. Also, as the sport of scuba diving increases in popularity, instructors have less time to build their own platforms, nor can they risk the product liability in case of product failure.

The Aqua -Dock is designed to meet the training needs of the instructor and adapt to a variety of dive sites while being operated easily and safely. As a scuba diver myself, I can appreciate the practicality of the Aqua-Dock for the training of students. As a designer, I can see that it has much more potential beyond this initial purpose.

The idea for the Aqua-Dock originated when I was a student diver in consultation with my instructor Dominic Gasbarre. He expressed a need for such a device and that it had no working precedent. Interviews with several other instructors re-affirmed his expression of need . Here, I found a unique chance to combine my thesis with one of my great interests.

RESEARCH

The first step in my design process was to see if there was some unknown, documented precedent that I could study and perhaps improve upon. Research through the Rochester Central Library's records and associated resources proved fruitless. Many hours were spent going over magazine articles, dive books, equipment lists and equipment evaluation sheets with no mention of anything resembling the Aqua-Dock. Consultation with several local and out of town dive shops and their long time instructors confirmed that the only platforms they knew of were those already in use and fixed to the sea floor. Several phone calls to the Diving Equipment Manufacturers Association (D.E.M.A.), Undercurrent (a diver oriented consumer magazine), the Underwater Society of America and several scuba manufacturers all reinforced that this was a unique idea and that I was on my own.

Satisfied that I was in new territory (for the product and myself) I continued my research. Many aspects were examined, including; the divers needs and wants, possible construction materials and processes, costs and mathematical computations concerning air, water and weight displacement. These will be addressed further in the processes section of this thesis.

DESIGN PARAMETERS AND OBJECTIVES

Design is an ongoing process that is forever evolving and improving upon what has been done before. New products, in particular, have no predecessors to learn from and are under constant change. Therefore, for the sake of time, space and clarity, I will limit the discussion of this part of the thesis to the original design parameters and goals. Alternative ideas and purposes will be discussed later on.

The initial purpose of the Aqua-Dock was to be a tool, used by scuba instructors, during the training of their students, in the basic underwater skills of scuba diving. The objectives set forth for this product can best be described in a scenario of how the Aqua-Dock would be used to fit the intended purpose. The scenario would go like this:

The Aqua-Dock could be taken to the dive site in one piece, or assembled at the dive site with minimal time and effort involved. Once assembled, the Aqua-Dock could be floated, towed or dropped off a boat into the water where the instructor was holding class that day. It could be left floating as a dive buoy / support dock held in place by any standard anchor or it could be sunk easily, unattended and relatively level to the sea floor. Once down, its supports would be adjusted to fit the variations in the sea floor so that the platform remained level. Student divers and their instructors would kneel on the platform as the students went through their drills. Other students, waiting for their turn, could hover around the perimeter. After the training session, the Aqua-Dock could be brought back to the surface easily, unattended and relatively level. It would then be towed, floated or brought back aboard ship and taken back to shore.

With the objective of efficient operation described in the preceding scenario in mind, design parameters were established to give me some boundaries in which to work and a focus in

solving the requirements of the project. The established design parameters are as follows:

-Design for the diver: The platform is to be used by divers for divers, so all designs were done to meet their needs. I took into account what would work best for them, how the platform would work with what they already have and how it would make their situation better.

-Three person capacity: While learning how to dive, my partner and I were brought down to our instructor by one of his dive masters. At that time the two of us faced our instructor and went through our drills. Since my diving instructor was a consultant and the students in his dive program were my test subjects, I opted to design around his method of teaching as well (Professional Association of Diving Instructors (P.A.D.I.) training course). This required a space large enough for three people, in full dive gear, to kneel facing each other without knocking into or crowding one another.

-Fresh water use only: By limiting the design to use in fresh water only, there was no need to worry about salt corrosion or the differences in densities and weight that exist between salt water and fresh water. This also eliminates having to be concerned about strong ocean currents, huge waves, coral damage or any of the other destructive or fragile natural elements associated with salt water. This parameter is included with the knowledge that the Aqua-Dock could be re-fitted for ocean use fairly easily following the same guidelines applied to the original design.

-Maximum 30-35 foot depth: Student divers are rarely taken down deeper when learning how to dive, therefore, the platform need not go down any lower. At 35 feet, you only have to deal with the pressure of two atmospheres instead of the increased pressures found at greater

depths. Also, greater depths means having to deal with less visibility.

-Simple to operate: When working underwater, your life literally, depends on your equipment. This includes all support equipment as well. The controls should be large enough to be operated while wearing dive gloves, of up to 1/4" thick neoprene. Visibility may be restricted under some circumstances, therefore it is important to be able to see and operate the controls properly and comfortably. I also feel that being able to use the platform easily and quickly is important in freeing the divers mind so that he/she may concentrate on more pressing matters.

-Mechanical simplicity: Keeping the mechanical operation of the Aqua-Dock simple should allow for easier repairs and hopefully reduces the cost of the product as a whole. Also, with simple mechanics, there is less chance of something breaking down or interfering with the rest of the platform.

-No riders while platform is ascending or descending: The initial purpose of the design was to be used as a floating dock or a stationary platform on the sea floor. It is not equipped to handle the weight imbalance that a rider would impose during ascent or descent. The Aqua-Dock has no metering system to gauge the rate of ascent or descent. Also, a diver at any depth, particularly student divers who are not used to sudden pressure changes, must have time to equalize.

-Lightweight: The more the platform weighs as a whole the less lift that you are going to get with the same amount of air. Beyond the mathematics lies the very human aversion to lugging about heavy equipment for any great distances on dry land. Regardless of how it gets there on land, the Aqua-Dock will have to be carried to the water.

-Easily disassembled: The ability to break down the Aqua-dock is important for off season storage and long distance transportation. This is necessary because of its large size when fully assembled.

-Sturdy: The Aqua-Dock must withstand being assembled and disassembled repeatedly, work in a variety of environments, varying temperatures, rough handling by nervous students and all the other little accidents that can happen to any product when people use it (dropping, misuse, etc.).

-Flexibility: Since there is no way of knowing what dive sites the Aqua-Dock may be used at, it must be flexible enough to adjust to a wide variety of conditions and users. (such as rocky, sandy or muddy bottoms, novices etc.)

-Level ascent and descent: In order to maintain diver safety, it was desirable to prevent the platform from flipping over. Level movement would also help keep any object that was brought up from the bottom from rolling off. Also, leveling would help in controlling the device and make placement on the sea floor easier.

-Use of computer aided design: Because of the increasing use of computers in the design field, I felt it important to incorporate the computer in my design process. It provided the ability to come up with many variations in design quickly, and to make alterations without having to start from scratch. Also, computer data is helpful after the design for documentation and preparation for production. All computer work was done on an IBM computer system. The program used for the 3-D design was Intergraph's Microstation. Microsoft's Windows program was used for graphics and presentation. All plots were done on a Hewlett-Packard 7586B, 8 pen plotter.

-Built with standard industrial materials: One of the tougher parameters was the use of standard industrial (off the shelf) materials in the design and construction. This was done for several reasons:

1. Try to keep the costs of parts, in production and repair, low
2. Make use of the durability and effectiveness of already proven and tested sub-units
3. Using these materials to build a working prototype (a decision made during the design process) proved the design theories and turned an academic and theoretical exercise into reality.
4. It is a personal challenge to create new and different uses for commonplace materials

INITIAL DESIGN PROBLEMS

A number of design problems can occur throughout the design process. There are, however, some problems that must be addressed before the project can even begin, especially with an undertaking of this size.

The biggest problem was time. The Rochester Institute of Technology, being on a trimester system, and having to prepare for a thesis show allowed for only three months in which to complete the bulk of the work. The time was sufficient to solve most of the initial design problems and present an all-around cohesive product. Additional time will be required to iron out details and to explore other design options.

The second biggest problem was that there was no product precedent. These were new concepts that were new to me as well. This meant that in order to make a logical presentation of my ideas, it had to be proven that they all worked. It also meant that it was important to make sure all the sub-units worked for the whole. This was one of the major factors in deciding to build a full scale working prototype.

Many of the other problems are common to all designers:

- What would the projected cost be?
- What size, shape, materials and production methods should be used?
- How to make the mechanics work simply and easily?
- How to put it all together?

Some of the problems were addressed by the creation of a time schedule and the preceding design parameters. The rest were a matter of process and testing out ideas.

PROJECT

PROCESS

All the different parts of the Aqua-Dock were worked on simultaneously. No individual part of the design was complete without it relating in some way to another part. Many new and consistently better ideas were generated to solve old problems which changed the design rapidly, even during the final construction.

These solutions did not present themselves unaided. Throughout this process there was constant contact with many different manufacturers and various industry professionals concerning all facets of the design and the outcome of the final project. The manufacturer's assistance, plus the bi-monthly meetings with my thesis committee helped me narrow down the design and stay focused on the parameters and objectives. The computer aided design was a constant part of the process allowing three dimensional visualization of different ideas and the ability to make design decisions from them.

To maintain some semblance of order and clarity throughout this section the design decisions will be presented by breaking them down into a description of the major parts and how they relate to the whole. Description of the decisions will be limited to those that were applied to this first prototype.

A portable, submersible scuba diving platform has many different aspects to it. Since research confirmed that this was a unique project, I started at one point and followed where it led.

POWER SOURCE

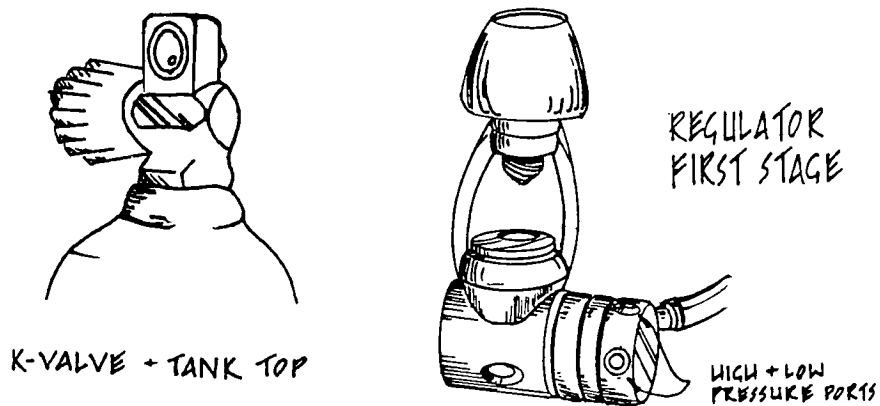

(Illustration 1.)

The two elements that a diver always has is water and air. Being able to utilize them would be ideal for the design. Compressed air is available from the tanks that divers carry on their backs. Instructors usually have a ready supply of tanks, regulators and other equipment available in their classes for those students who cannot afford all the equipment at once, but still want to learn the sport. Being able to use some of the instructors own equipment would lower the inherent cost of the Aqua-Dock for them. With this in mind, it was decided to use the tanks as the renewable power source. Tanks come in various sizes and capacities, therefore any design would have to accommodate whatever tanks the instructor used for his classes. A 3000 psi, 80 cu. in. tank was used for this thesis studies. It is one of the larger size tanks.

In order to transfer the air from the tank to the Aqua-Dock, a Sherwood regulator was used. A regulator is standard equipment for all divers. The main part of a regulator is its first stage. The first stage is the piece that actually fits on the air tank and reduces the pressure of the compressed air. A regulator has four ports that accommodate two types of hoses. One of these is a high pressure hose that goes to the pressure and depth gauges, the other three are low

pressure hoses that go to the second stage mouthpiece, emergency mouthpiece and the BC (buoyancy control). The BC is the jacket that the tank is strapped to. The capacity of the low pressure hoses is approximately 250 psi. A low pressure system was chosen for safety and better monitoring of the air flow. In order to join the elements of scuba and industry a link had to be created through one of these hoses. The BC connector was fitted with a 1/2" female connector that would match up with the rest of the valving that will be described later.

PERIMETER (FLOAT)

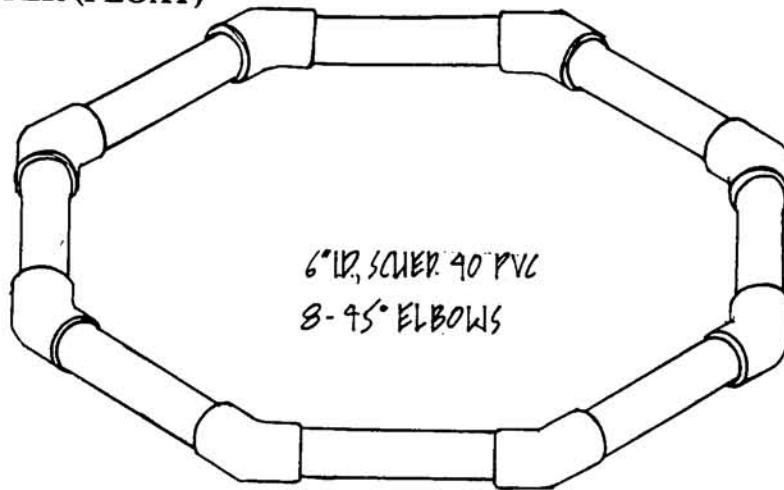

(Illustration 2.)

When this thesis began I interviewed a certified dive instructor of long experience who helped me form the first thoughts as to how the Aqua-Dock would eventually look and work. We concluded that in order to have a platform you would need some sort of surface to work off of and a perimeter in which to enclose it. A perimeter at least 6' in diameter (to accommodate three kneeling people) was needed but what shape should it be? Basic geometry tells us that a circle gives the greatest amount of area with the least circumference. An octagonal shape was chosen because it approximates a circle and can be fabricated without making special parts. An octagonal shape also gives eight straight sides to work with. This was the only part of the design that did not change throughout the thesis.

We also concluded that the platform should remain as level as possible during ascent and descent and while on the bottom. This meant that to offset the tipping it would need to have a higher point of bouyancy around the perimeter with a lower centerpoint of static weight. Having a buoyant perimeter meant that it needed to be hollow and of a fairly large diameter to give enough lift. Mathematical equations, concerning the available space and the displacement of water from that space, helped determine that a perimeter 6 feet in diameter using 6" ID (inner diameter) tubing would be the most practical.

EQUATIONS

FOR 6' DIA. OCTAGON USING 6" ID PVC TUBING

pi * radius squared= The Area of a circle

$$\pi * R^2 = A$$

$$3.14(3)^2 = A$$

$$3.14(9) = 28.26"$$

Area * Length= Volume

27.6"= The length of each cylinder

$$A * L = V$$

$$28.26" * 27.6" = 779.976 \text{ cu. in.}$$

$$779.976 * 8 \text{ (total number of cylinders)} = 6239.808 \text{ cu. in. totally}$$

$$6239.808 / 1728 \text{ (the number of cu. in. in 1 cubic foot)} = 3.611 \text{ cu. ft.}$$

1 cu. ft of fresh water =62 lbs

$$3.611 * 62 = 223.882 \text{ lbs of water displaced by air in the perimeter.}$$

223.882- The total weight of the platform= estimated amount of lift

These equations were also applied to 8', 7' and 6' diameter octagons using 4", 5" and 6" ID tubing.

What eventually came out of the search was 6" ID, schedule 40 (c. 1/4" thick) PVC (polyvinyl chloride) tubing. It is basically sewer pipe that is very tough, can handle up to 250 lbs of internal pressure, is a standard plumbing component and can be solidly cemented to other PVC materials. Therefore the choice of 6" ID tubing did not come about arbitrarily, though it was the largest size commonly available. The equations used provided an approximate number to work with in terms of the overall design. The total weight of the platform had to be kept under 100 pounds if an equal (c. 100 lbs.) amount of lifting (buoyancy) capability was to be achieved.

After choosing a size, shape and initial working material, it was important to test out the ideas to see if they would work at all. To do this several 1/8th scale models were made out of 3/4" ID, sched. 40 PVC tubing. The initial tests were done in the RIT Industrial Design shops sink using the shops pneumatic hose as an air source. Subsequent test were done in the RIT pool which simulated depth at scale.

The first model was a solid octagon of PVC tubing. The next five variations of the original were all tests on filling and dumping the air. It became clear quickly that to try and fill the entire perimeter from one point was time consuming and made balance and disassembly impossible. To rectify this, the perimeter was blocked with PVC disks at equidistant points breaking the one solid tube into four separate chambers.

Each chamber would have its own air fill and dump holes. The fill hole would be placed on top at one end of the chamber and the dump hole would be on the bottom at the other end of the chamber. This insured that the air would not blow straight out the dump hole and that the entire chamber would have to be filled for the air to finally escape through the dump hole. Because the chambers are equidistant from one another the air should distribute evenly and it

should be possible to control the air flow to each chamber if need be. By placing the PVC blocking disks deeper into the ends of the four chambers they could be connected with a single bolt at each intersection. This created a dead space at the connection point. This small space of air (.065 cu. ft.) seemed to be negligible to the whole. (see illus. 3, pg. 15)

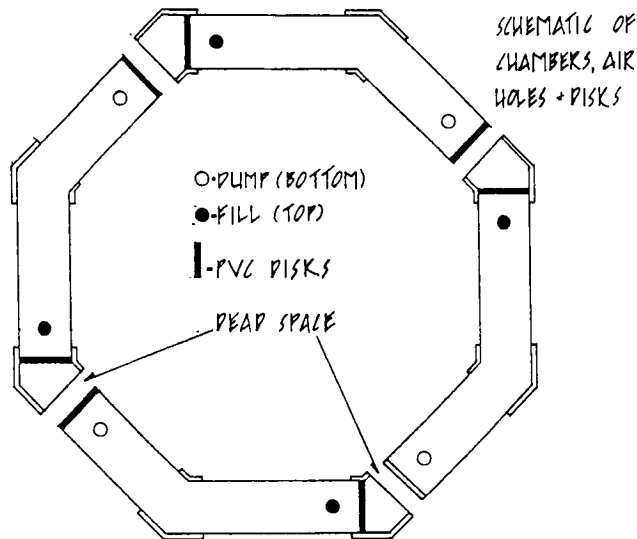

(Illustration 3.)

Tests in the sink showed that, with a constant air flow, the perimeter ascended evenly, even after some initial imbalance. Later tests, in the pool, showed that the perimeter, completely filled with air and completely filled with water, ascended and descended evenly. Several similar tests were done using a heavy center weight, minimal off center weight and solid and mesh covers that all showed the same even rate. Heartened by this success, full scale sections of PVC tubing were tested in the sink. Once again, the material responded as hoped and plans for the final design began.

CENTER SUPPORT

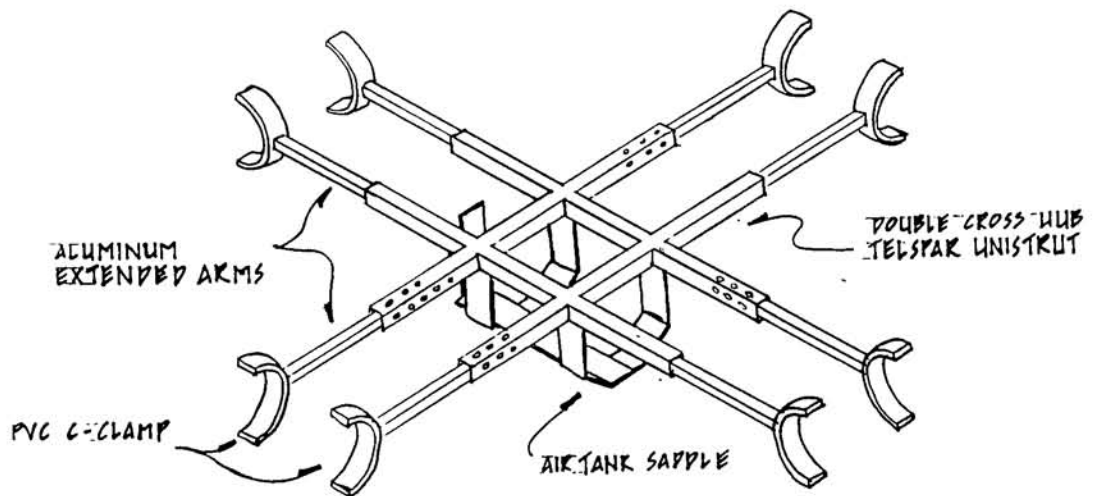

(Illustration 4.)

Deciding on a float, it had to be determined how to support it and its power source. This problem was addressed with the understanding of two things: 1) The tank, regulator and all subsequent valving had to be centralized for balance and better control and 2) The tank should be able to be secured in place from above and below the platform.

The tank should be able to be secured in place from above when the Aqua-Dock is on dry land so that the platform will not have to be tipped on end. Also, the regulator should be attached out of the water because it is harmful to the equipment if water is run through it. Being able to access the tank and valving from below would be useful for operating it in the water and when the Aqua-Dock is floating on the surface. It gives the diver buoyancy control on both planes.

What is the minimal amount of structure needed to hold a scuba tank in place suspended within an octagon? This was the next question on the agenda. Using the straight sides of the octagon, it was possible to clamp a simple, thin armed cross to the perimeter which would give me the support structure I needed. Expanding on this idea, knowing that support was needed for the

platform base and allowances had to be made for placement of the tank, it evolved into a double cross. This double cross gave greater support from the perimeter, room between the adjacent arms for securing the tank and twice as much surface area to attach the platform base to. Unistrut Telspar tubing was chosen to form the hub of this center section. It is corrosion resistant (galvanized steel), extremely strong and inherently heavy (which would aid in countering any tipping).

Since the Telspar was intended only for the hub, it needed to have arms that extend from it to the perimeter. Telspar is square and can be purchased already perforated which makes construction of the extended arms much easier. Square tubing prevents the extended arms from rotating once they are locked in place and gives a flat surface to build the platform on. For the extended arms I chose square aluminum tubing that is strong, corrosion resistant and easily worked but much lighter in weight than the Telspar. The aluminum would extend from the inside of the Telspar to the perimeter, held in place by carriage bolts.

In order to hold the tank securely, a saddle was constructed that it would slide into and be held in position. The saddle consists of two U-shaped aluminum bars with one inverted, elongated L-shaped bar that joins the two U's. A velcroed BC strap across the center holds the tank securely in place. Pieces of closed cell neoprene are attached to the inside of the saddle for greater friction and to prevent the tank from rolling while in the saddle. The tank can be removed quickly and easily for replacement or in case of an emergency (if an extra tank was needed to breathe from). (see illus. 5, pg. 18)

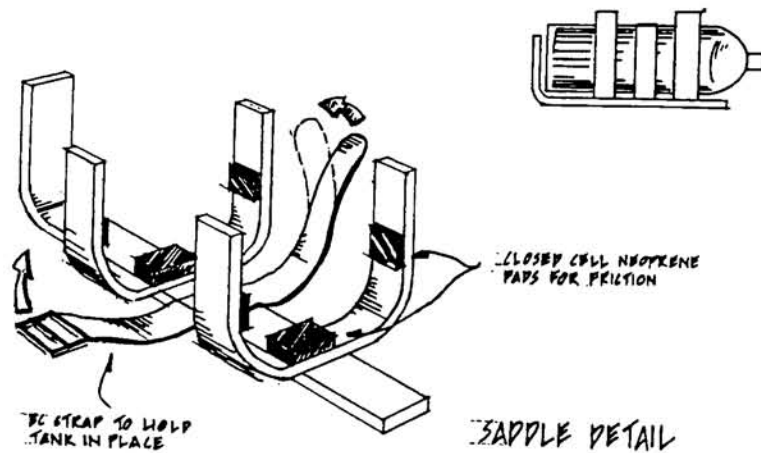

(Illustration 5.)

The toughest part of the inner structure was how to attach a square hollow tube to the cylindrical perimeter without making more holes in the chambers than is necessary. The answer, ironically, came during the construction of the final full-size prototype. Smaller sections of the PVC tubing cut into a C shape fit snugly and firmly around the cylinders. There was no need for extra holes in the chambers but, a round surface still had to be attached to a hollow flat surface. Screwing it in place seemed the most effective solution. Round PVC rod that fit inside the aluminum was used. The rod was held in place by a bolt that went through both the aluminum and the PVC. The C clamp was bolted through its center into the PVC rod. Washers were placed on either side of the C clamp to spread out the stress forces that would be acting on that connection. (see illus. 6, pg. 19) This was a jury rigged solution to the initial problem of construction. Alternative production methods will be discussed in the Application of Design section of this thesis.

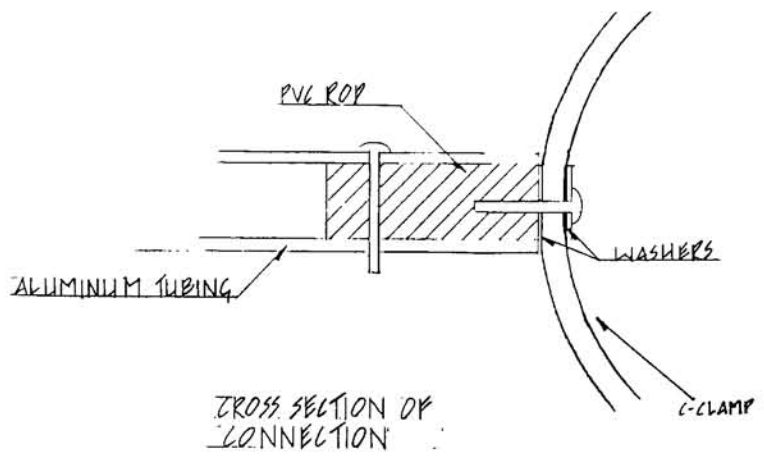

(Illustration 6.)

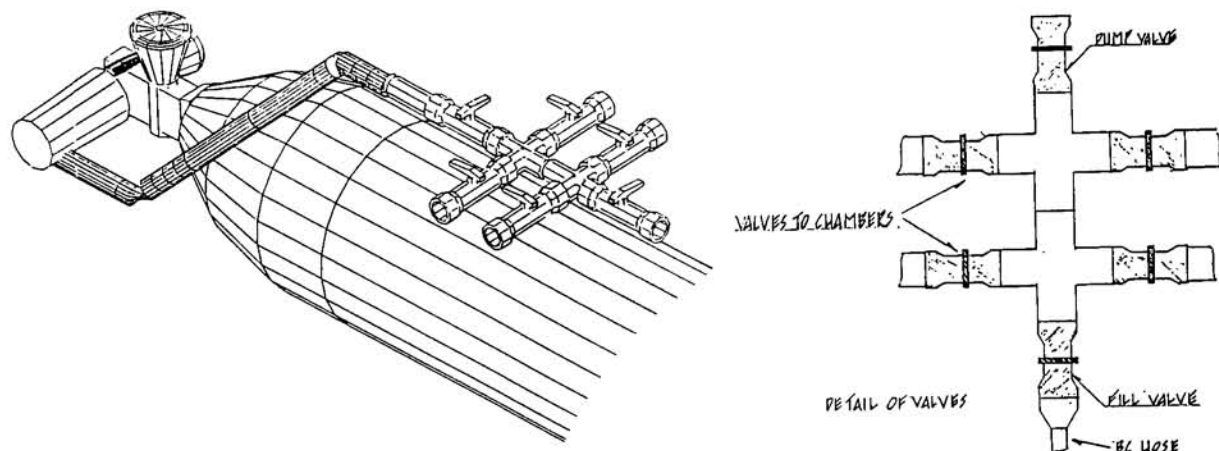

(Illustration 7.)

It was mentioned earlier that the mechanics were to be kept as simple as possible. Natural forces, if used correctly, could do a majority of the work. The idea behind the dump and fill system was very simple. By opening a dump valve in the control area, an open airway would be formed to the chambers. The ambient pressure of the water (being greater than that of the air pressure in the Aqua-Dock) let in through the dump holes, would force the air out of the chambers through the central dump valve. As the Aqua-Dock took on water, its density would become greater than the surrounding water and it would sink. To raise the Aqua-Dock you would close the dump valve and open the fill valve that was connected to the air tank. Compressed air would fill the chambers and displace the water that was there, forcing it out the dump hole. As the chambers filled with air, the perimeter would become less dense than the surrounding water and would rise. When the chambers completely filled, the excess air would bubble out of the dump hole. This prevented any sort of pressure build up since it was an open system when ascending or descending. With both the dump and fill valves turned off it became a closed system that neither let air out or water in allowing the Aqua -Dock to remain afloat.

The controls for the Aqua-Dock should be simple to use, centralized and sufficient to handle the air pressure (approximately 250 psi for a low pressure system). The original thought was that all four ports of the original regulator, could be used extending their hoses to the four chambers and let the air come back through the hoses for descent. Several factors made this impractical. They are: 1) one of the ports is high pressure and this is a low pressure system 2) the rate of air flow back through the hoses would be very slow and 3) you should not force water through a regulators first stage because the water will damage it.

1/2" hoses and connectors were found that could handle the pressure. It was possible to construct a one hose system to each chamber and use the valves and hoses to serve a double purpose. This allowed for the air to fill (and dump) to a central point, where it would be distributed evenly. Standard ball valves and PVC connectors were used to form a double short armed cross. (see illus. 7, pg. 20) These valves were also chosen because they had to be rotated to be opened. Ambient pressure at depth can play havoc with push button controls but it cannot turn a switch. The four valves extending equally from the center led to the four separate chambers. (see illus. 8, pg. 22) This allowed individual air control of each chamber. The valve at the top of the cross was the dump valve that opened up to the water itself. The valve at the bottom of the cross was attached to the specialized BC hose that connected to the air tank through the regulators first stage.

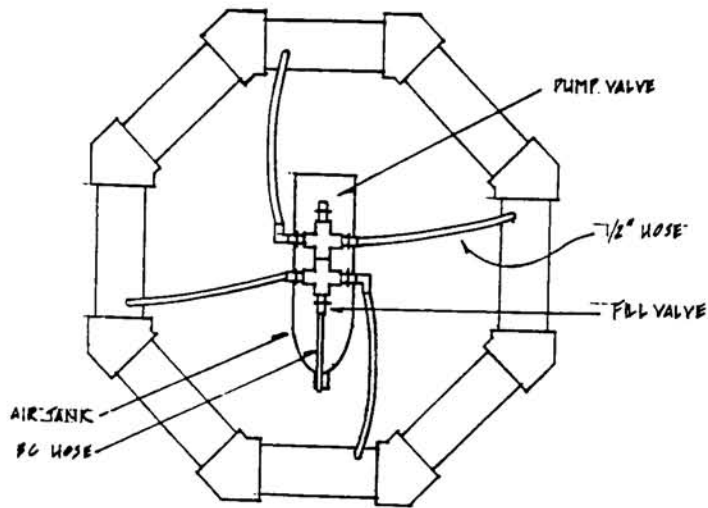

(Illustration 8.)

L-connectors were used to attach the hosing to the chambers. These were put on one end of the chamber to offset the dump hole that was on the bottom of the other end. They were also placed slightly down the inside face of the cylinder so there would be less chance of them being in the way or getting damaged. The L-connectors were rotated 30 degrees to the inside of the perimeter to prevent kinking in the hose and provided a more direct air flow. (see illus. 9, pg. 22) Bill Shaw of Mitten Fluidpower was of great help to me in matching up all the fittings and altering the scuba hose for its new purpose.

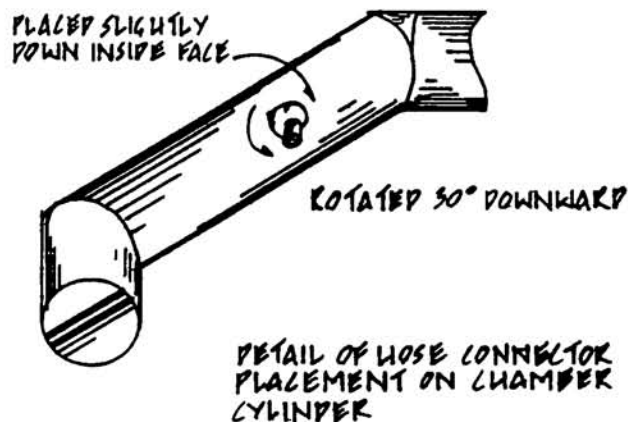

(Illustration 9.)

LEGS

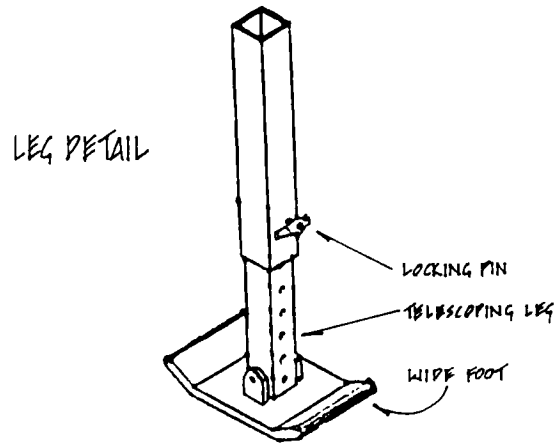

(Illustration 10.)

The legs telescope with a minimal length of 12" and a maximum length of 20". The minimal length of 12" allows for clearance of the scuba tank that is suspended in the center of the platform. The telescoping legs are needed for adjusting to a variety of sea floors in order to keep the platform relatively level. The legs also keep the main structure from sitting on the sea bed where it could literally get stuck in the mud.

In order to prevent the legs from driving into the sea floor like tent poles, wide feet are needed. These would distribute the weight of the Aqua-dock and its users so that any sinking in the mud is minimal. For this prototype, static aluminum legs were welded to four of the extended arms and had closed cell neoprene nailed on as feet. This was a jury rigged solution to the initial problem of construction. Alternative production solutions will be discussed in the Application of Design section of this thesis.

PLATFORM BASE

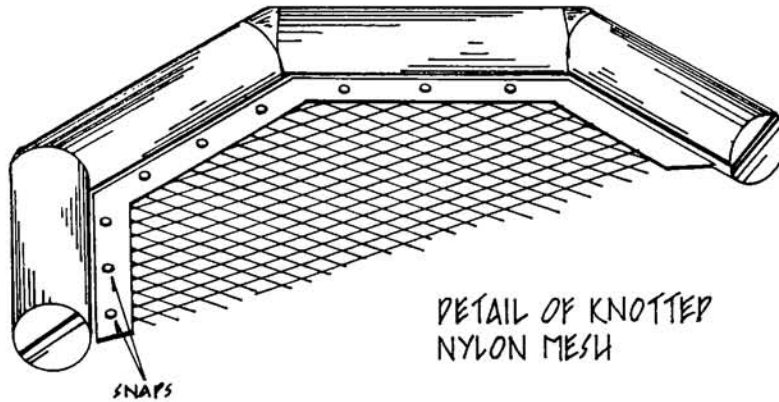

(Illustration 11.)

The platform base is the actual element that the divers would be kneeling on when they go through their drills. The base had to be made of a lightweight material that could also be broken down for storage. It had to be perforated in some way to allow the water to pass through to prevent a leafing effect during descent or a drag during ascent. Most of the inner hole of the perimeter had to be covered and space had to be made to fit the air tank through. This became one of the longest and in depth material searches in the thesis. Many options were considered and discarded because of weight, corrosion or cost.

Eventually, knotted nylon mesh was chosen. It is tough, durable, all-weather, non-corrosive mesh that can be worked with in many ways. This mesh would be stretched across the center of the perimeter much like a trampoline. The fact that its meshing is knotted together lets you cut it where ever you want and it will not unravel the whole. The mesh allows for water to pass through it with little or no resistance and is available commercially in a number of varying tightnesses. Also, the control switches fit easily through the mesh eliminating the need to cut it more.

[REDACTED] To attach the mesh to the perimeter, the plan was to sew an octagonal canvas rim to the mesh that could be snapped to the perimeter. The female part of the snap would be clipped into the canvas, while the male part would be short screwed into the PVC perimeter. A flap in the center could be opened for placing the tank. It would work much like a boat cover. The mesh could also be used to clip extra equipment that the diver might want or need. On the prototype the mesh was stapled to an octagonal frame made of wood and bolted to the inside of the perimeter. This was fragile but adequately represented the mesh's intended purpose.



MISCELLANEOUS

In preparation for the thesis show the Aqua-Docks perimeter was painted a bright fluorescent yellow (Yuba yellow) and the rest of it black. This allows for greater visibility underwater and follows the trend in contemporary scuba equipment of offsetting black with bright primary or fluorescent colors. To help explain the purpose of the Aqua-Dock several computer generated images were also used in the presentation. The sum of this endeavor was a full-scale working prototype that could be used to further test out the design theories and improve upon them.

EVALUATION

The tests that were done on a 1/8th scale gave insight into how the Aqua-Dock would work ideally under controlled conditions. It was during the full scale tests that much more was learned.

There were three test done in the RIT pool at full scale. The first test, prior to the thesis show, proved that the Aqua-Dock indeed floated well. So well as a matter of fact that one had to question the validity of the initial calculations. Going over the numbers again showed a miscalculation in the amount of displacement and testing proved that the Aqua-Dock could hold considerably more before it became overweighted. This was more of an asset than a problem. While floating, the Aqua-Docks water level is at the mid point of the cylinders.

Several problems made themselves known right away however. The weight of the air tank in the center was supposed to help offset the tipping, since it weighs approximately 30 pounds on dry land. Unfortunately, a full compressed air tank is almost neutrally buoyant in the water and as it empties becomes positively buoyant. The saddle held the tank in place well but, more weight had to be added to the center.

In order to deliver the air to the valves, the remaining ports on the regulators first stage were stopped up. This gave no allowance for bleeding which is one of the purposes of the other hoses. The result was an overflow of air blowing out at the first stage connection. In subsequent tests all the other hoses were left connected and it worked perfectly.

It became obvious that it was even a benefit to leave the other hoses connected. They would tell you how deep you were, how much air was left in the tank and the emergency mouthpiece could be used by some one who was in trouble.

Another problem with the regulator was its make and model. A Sherwood regulator was used as the air control. That meant that the hosing that was jury rigged only worked on that model regulator. To suit the needs of all divers a rigged up hose would have to be made to fit all the different types of regulators in use, or a specialized regulator would have to be designed to work only with the Aqua-Dock.

The Aqua-Dock did sink and did come back to the surface, but an apparent imbalance in one of the chambers caused it to tip dramatically and continue to do so even on the bottom. By tipping I mean that one side sank faster than the other. Once the excess air was shaken out of the highest chamber, the Aqua-Dock sat evenly on the bottom of the pool. Air will always travel to the highest point and once the tipping started there was no stopping it. All subsequent tests were aimed at getting the Aqua-Dock to ascend and descend relatively even.

For the second series of tests, extra weight was added to the center, but not enough was available to make a difference. It was also noted which chamber sank faster than the others and what was unusual about it. For the third test, an extra dump valve was added to the chamber that consistently stayed floating. This valve was added to the top of the chamber whereas the original L-connector had been attached off to the side. The idea behind attaching the connectors off to the side was to keep them safe and out of the way. It was believed that the small amount of air that would be left in the chambers would be of no consequence.

We were wrong. As it turned out every bubble of air made a difference. What this succeeded in doing was causing the revised chamber to sink more quickly losing all of its air through the top opening.

While being held level on the surface in shallow water the Aqua-Dock did sink and rise evenly, even gracefully, but this is impractical at greater depths. It did prove to me though that the Aqua-Dock would work as planned if the air could be evenly dumped and filled.

These tests gave offered several ideas on how the problem might be solved.

1) Restructure the inside of the chambers in some way so that the air was forced to go in and out evenly. This could be done by adding more stops within the chamber to guide the air or by adding buoyant elements such as styrofoam, or static air pockets.

2) Develop a metering system, either computerized or mechanical, that would gauge when the Aqua-Dock was tipping and make adjustments by opening and closing off the air flow to different chambers to maintain balance.

3) Remove and introduce the air so quickly that the Aqua-Dock doesn't have time to go off balance. This occurred to me after reviewing the first tests with the 1/8th scale models. The air hose from the industrial design work shop at RIT blew air at much greater pressure at scale than the scuba tank did at full size. The air flow system would have to be adjusted to handle the greater pressure.

4) The heaviest single piece of the platform was the perimeter. If the same amount of space

could be created using a lighter material with the weight still in the center it would hopefully follow the example of its smaller predecessor.

In general the Aqua-Dock fulfilled or surpassed all of the design parameters originally set for it. The only major problem was the uneven sinking and raising but I believe that can be rectified by any of the above mentioned solutions. As a first run prototype I would say it worked remarkably well. Future development would require the assistance of other technical disciplines that have a greater understanding of materials, water and air displacement and production methods.

APPLICATION

APPLICATION OF DESIGN (PRODUCT DEVELOPMENT CONCEPTS)

To put this design into production, it could be developed in two ways. The first way, is selling the blueprints of the design as a do-it-yourself kit. Any aspiring dive instructor could buy the parts himself and construct it the way I did. The second idea is to tool for production by a manufacturer of scuba equipment, or related production materials. Assuming the best, the Aqua-Dock can be foreseen as a low production item of 3000- 5000 units a year. To tool up for production, however, it would have to go through some radical redesign.

Keeping the perimeter octagonal, it would have to be redesigned to serve in more ways than its present function. It would be manufactured using rotational molding. This would not only allow for greater diversity in design but, could lower the total weight of the perimeter by using different plastics in the production.

"Rotational molding is a process for the manufacture of hollow forms in a limited number of plastic materials. Tool costs are low, only a female mold is used, and the production rates are slow. No molding pressure is required at all, so the tooling can be lightweight and simple to construct. The process is often used to produce large one-piece tanks and containers that would be extremely difficult and costly to make by any other process. In contrast to blow molding, rotational molding does not stretch the material; parts, therefore, do not have thinning at the corners or edges." (Hoogesteger 1987, 66)

Using the rotational molding process a solid lip that would run along the inside meridian of the perimeter could be designed into the mold. The male part of the snaps could be put through this lip without fear of compromising the solidity of the chamber. The same knotted

nylon mesh could still be used in much the same way as the original design.

Without having to support as much weight there is no need for the double cross center support. Female bracing holes could be added to the design of the mold to fit two parallel bars that would support the air tank in the center of the platform using the same saddle idea. The legs, still made of aluminum, could be fitted into additional female bracing holes on the bottom of the perimeter. This can be achieved with the addition of a threaded female insert that could be cemented into the negative space. The tops of the legs would be fitted with the threaded male counterpart. (see illus. 12, pg. 33) This would give greater support to the entire platform and make it easier to reach the legs for adjustment underwater. The Aqua-Dock would still be able to be disassembled, but the ends would either be formed to lock together independently or with the aid of a separate locking device. (see illus. 13, pg. 34)

The Aqua-Dock would have a two control system. One control would cause it to sink. By turning that one off and turning on the other one the Aqua-Dock would rise. A switch control would still be used because ambient pressure under water will not effect its performance. To ultimately save money and hassle for the instructors, a specialized regulator head with all its own fittings would come with the Aqua-Dock . This would create one independent system needing only the instructors own tanks and air. Gauges that tell how much air was left in the tank and the depth would also be part of the control panel design.

(see illus. 14, pg. 35)

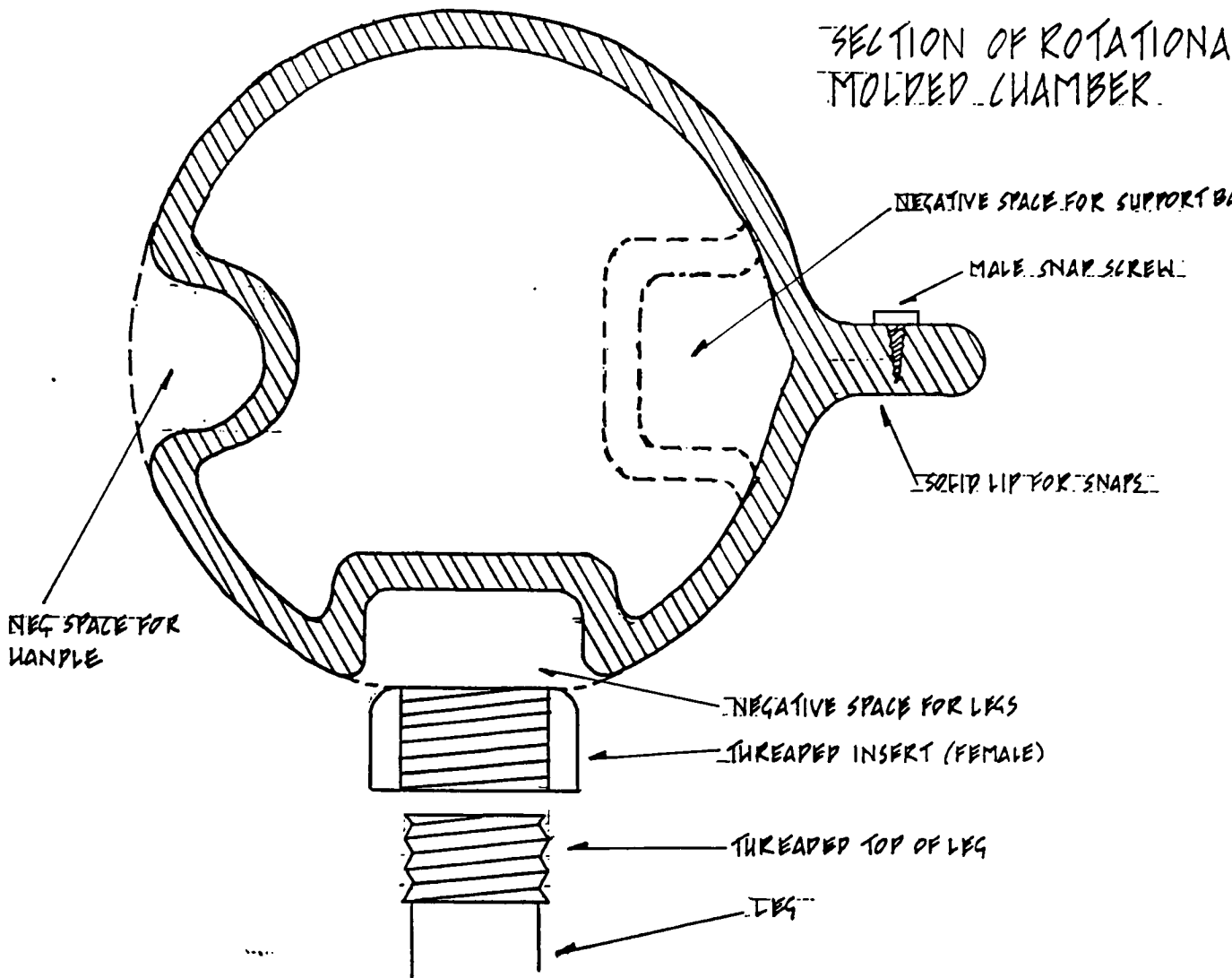

(Illustration 12.)

DETAIL OF MOLDED
CHAMBER CONNECTION

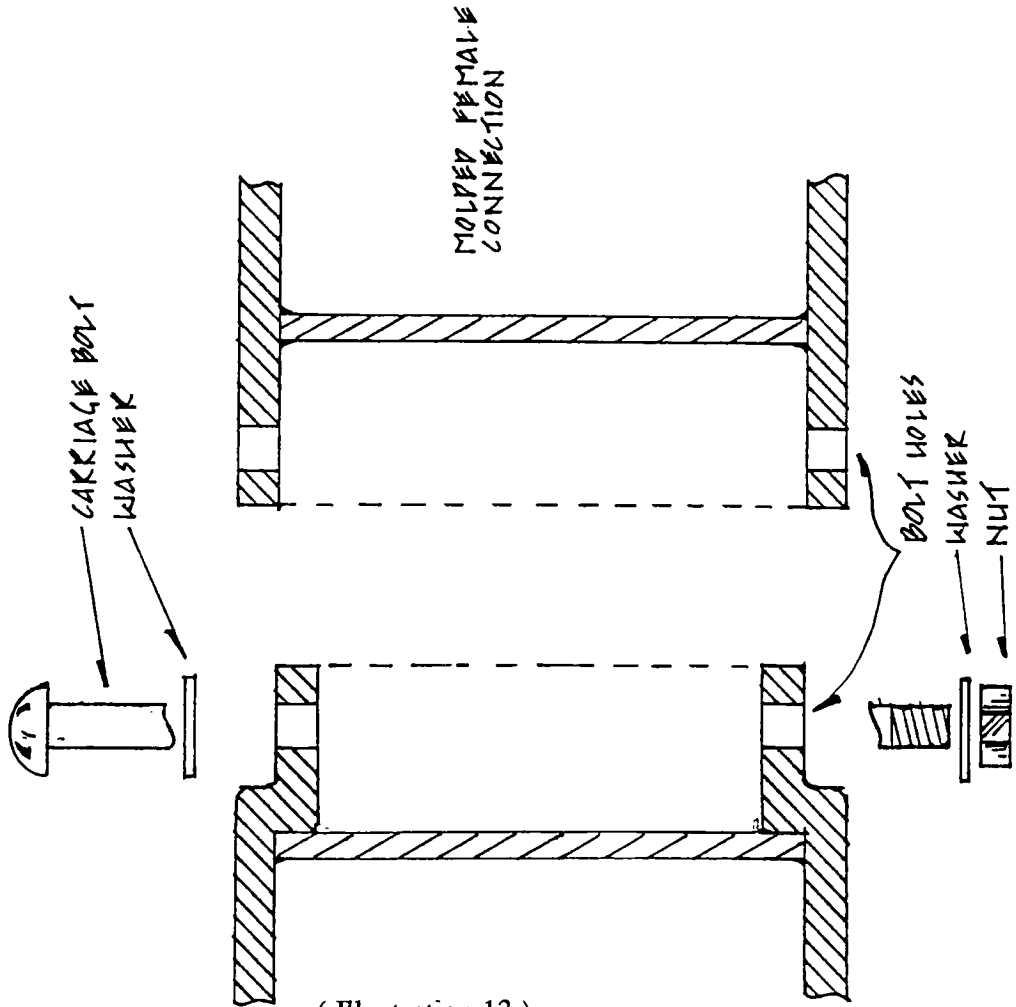

(Illustration 13.)

BOTTOM VIEW

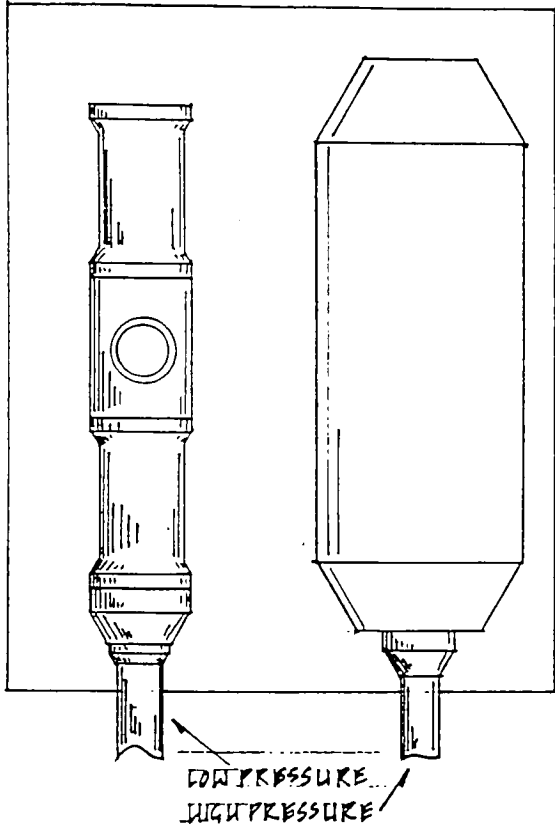

TOP VIEW

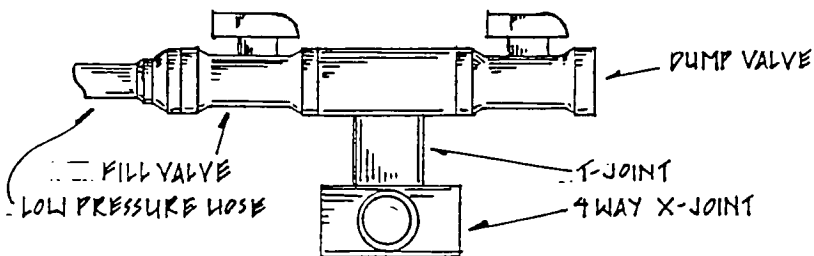
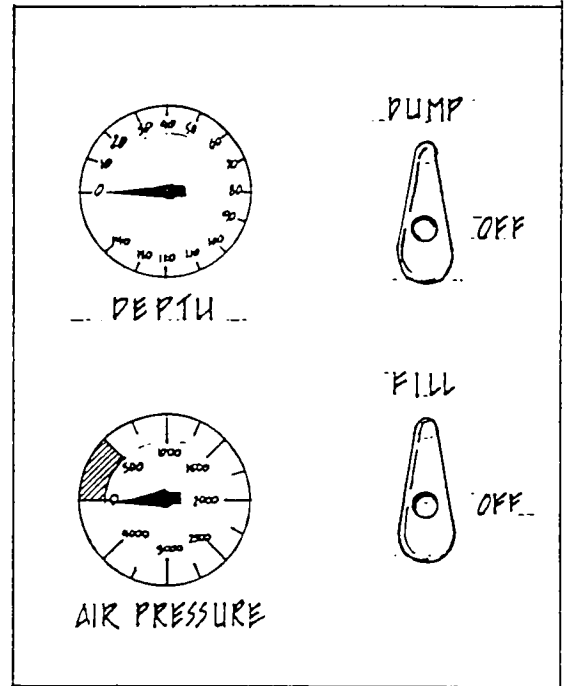

DETAIL OF CONTROL PANEL

(Illustration 14.)

The color should continue to follow the contemporary style of black with very bright primary and fluorescent colors accenting it. Open cell neoprene (which floats) would be used to cover any hard areas that would increase comfort and add to the buoyancy of the whole.

To give the Aqua-dock an identity of its own (even within a corporate structure) a logo was conceived that utilizes both the name and the shape as an identifying mark. The name Aqua-Dock came as a derivative of the platforms function. Using both upper and lower case letters of Review typeface, an initial logo with a signature below it was created. The two upper case letters "AD" had such a strong presence, it was decided to use them instead of a picture for the main focal point. When these two letter are stretched out in Review type they almost form a silhouette of the Aqua-Dock itself. The initials with the name below make the mark unmistakable. This logo could be placed anywhere on the Aqua-Dock with great effect but, it would be most effective on the outside of the perimeter. (see illus. 15, pg. 36)

(sales sheet design idea, appendix iii, pg.80)



(Illustration 15.)

APPLICATION OF DESIGN

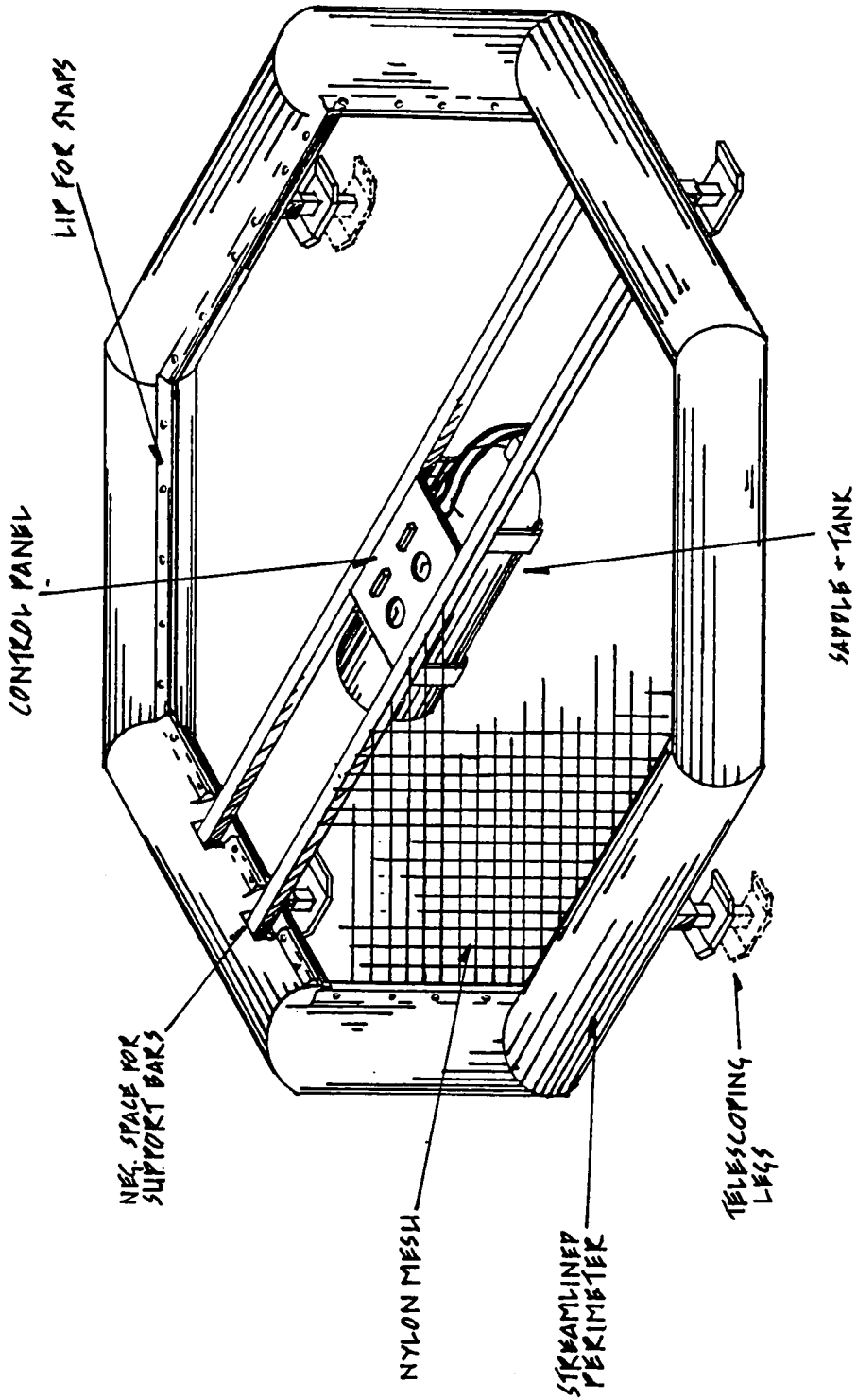

(Illustration 16.)

ALTERNATIVE DESIGNS

The Aqua-Dock, as it stands, has a maximum capacity of three people at a time. It cannot support riders or heavy objects and needs to be treated as a single function piece of equipment. I know the Aqua-Dock can expand beyond these limitations. Future designs could look into expanding its functions, design parameters and repositioning and modifying its sub-units.

One very probable expansion would be increasing the size of the Aqua-Dock by elongating it horizontally. The two central elongated cylinders could then become solid air chambers independent from the ends. Therefore, the ends do not have to be disassembled, but can be hinged and folded up so that, from the front, it forms a square U shape. (see illus. 17, pg. 39) They could be locked in their 90 degree position, while the whole is attached to a flat trailer. (see illus. 18, pg. 40) Shaped blocks would fill the space of the hinged sections to give extra support and take the bulk of the weight off the hinges. The Aqua-Dock would become the bed of the trailer. (see illus. 19, pg. 41) All the scuba equipment, extra tanks and gear could be tossed into it for transport. Since the chambers are independent of each other, there is no problem of damaging any connections.

Also, instead of increasing the size, perhaps it could be decreased for single person use in salvage or rescue. It could be inflated with a mini-tank or through a divers BC hose. Different shapes of perimeter, number of chambers and methods of inflation are all further variations that could be made in the design.

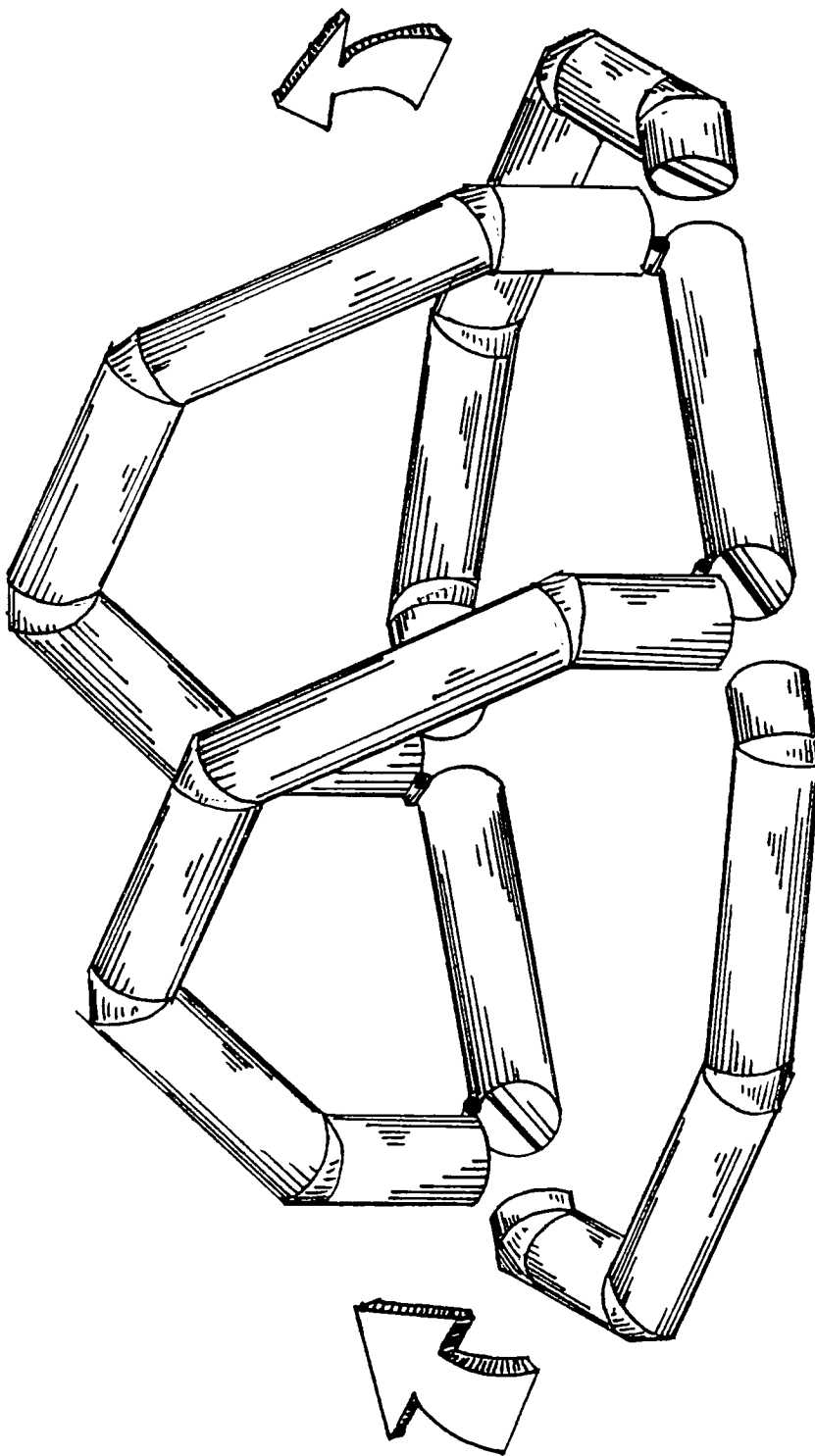

FOLDING ROCK

SCHEMATIC OF CHAMBERS

SOLID AIR CHAMBERS

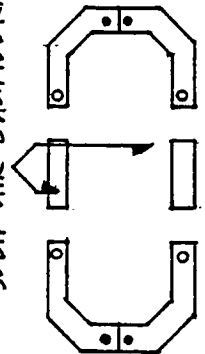

●=FILL
●=PUMP

(Illustration 17.)

DETAIL OF HINGE

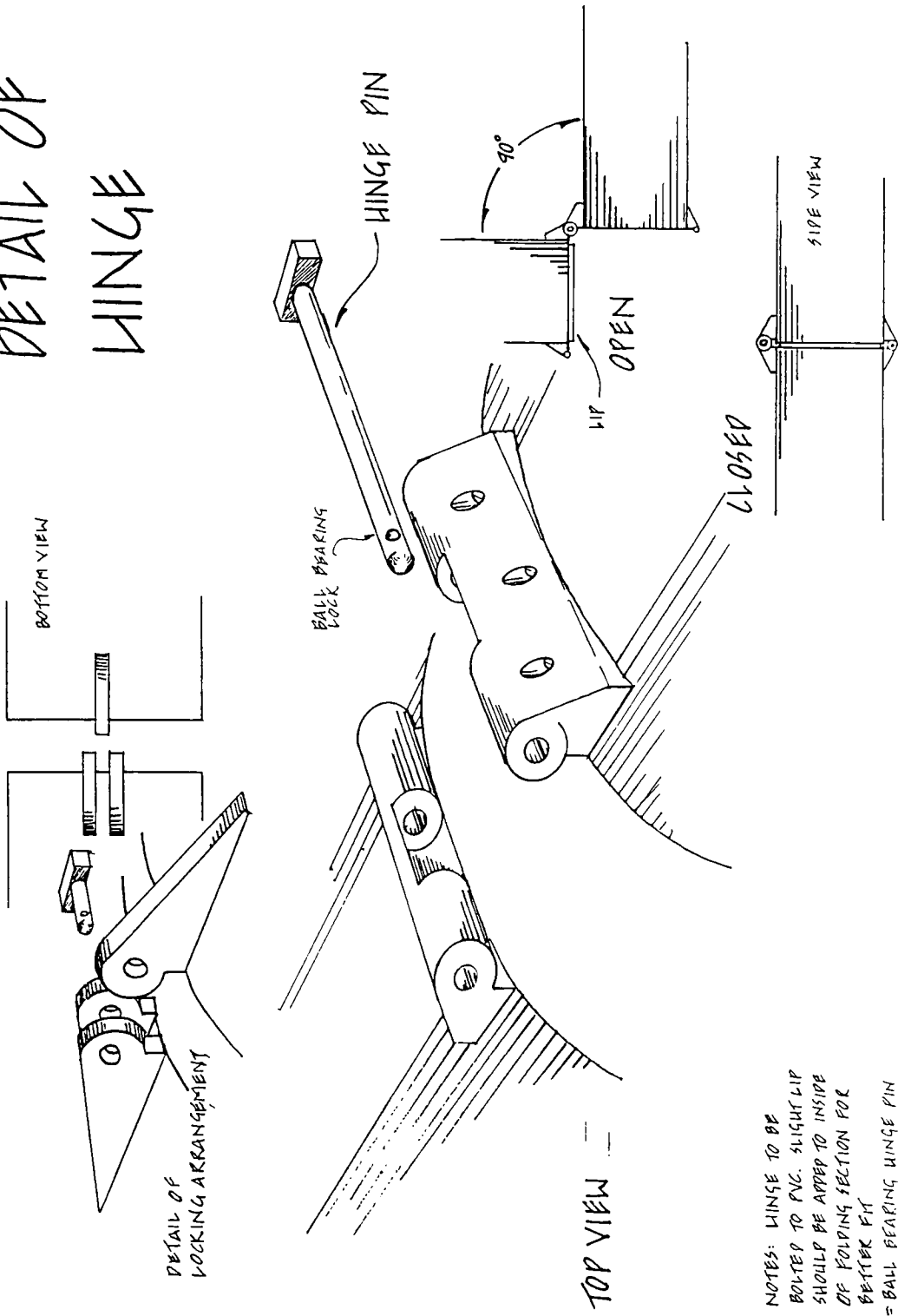

NOTES: HINGE TO BE BOLTED TO PVC. SLIGHT LIP SHOULD BE ADDED TO INSIDE OF FOLDING SECTION FOR BETTER FIT = BALL BEARING HINGE PIN

(Illustration 18.)

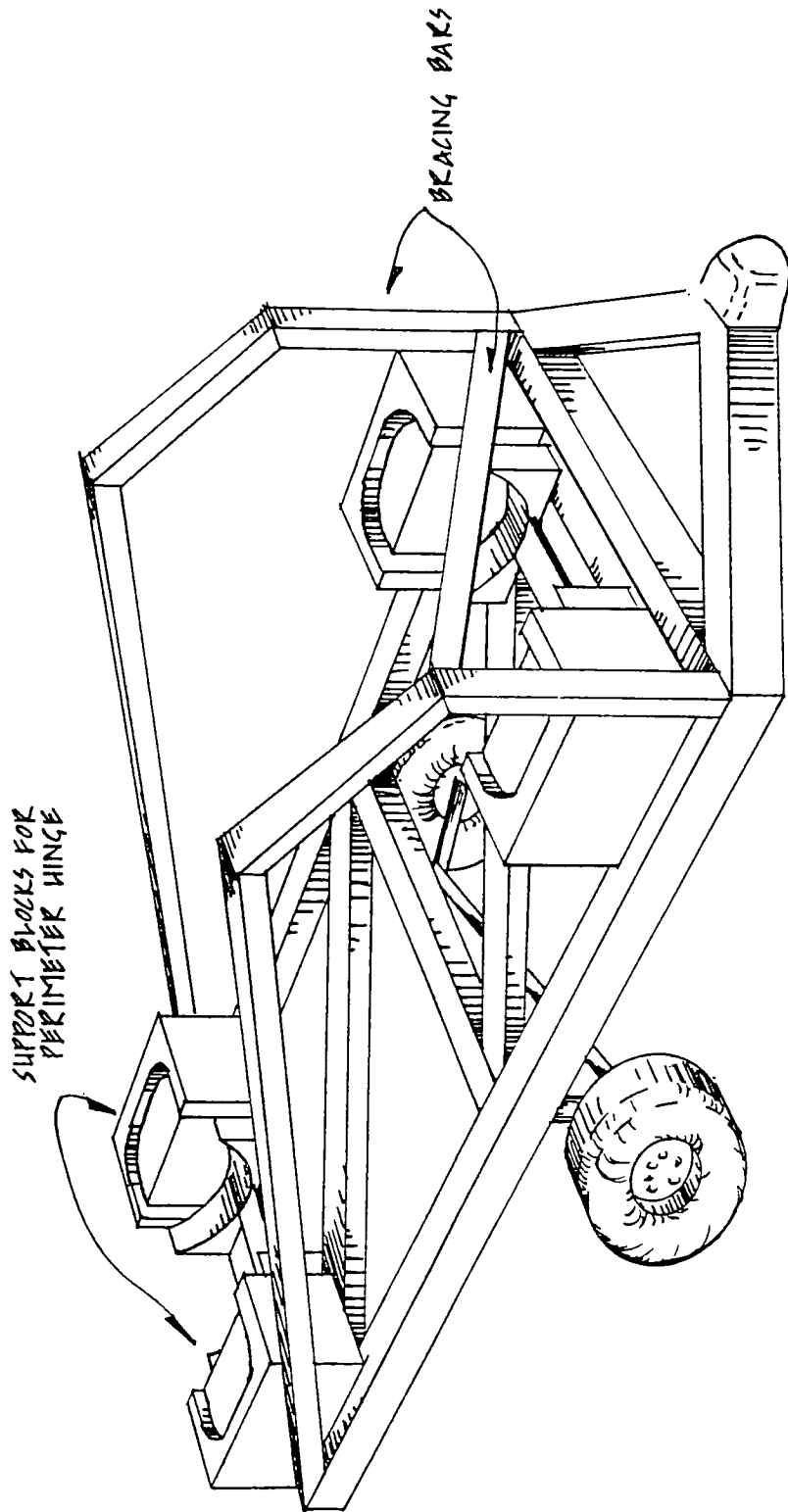

BASE TRAILER PLATFORM
IS MOUNTED ON

SIDE VIEW OF
PLATFORM ON TRAILER

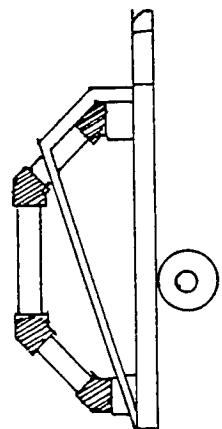

(Illustration 19.)

Additional equipment and variations that could be added to the design include:

- lights for night diving

- couplings, to link several platforms together

- handles for carrying

- an extra handle bar to grasp while hovering underwater or floating on the surface

- compartments for tools, special equipment, etc.

- ability to carry extra tanks



CONCLUSION

Since construction began on the Aqua-dock, I have considered it a work in progress. It has so much potential to expand in so many directions, it is hard to say where it might lead. All aspects of it however, look promising.

I personally feel very proud of the work I did on the Aqua-Dock. Every solution revealed another problem and every answered question sparked ten more but, it was worth it. It forced me to work beyond what I thought were my limitations. It allowed me to use my imagination to picture a final solution and then make it a reality. It gave me a chance to make contacts with in the business community and to see how business is done and deals are made. I have high hopes that the Aqua-Dock will one day become a useful, marketable product.

BIBLIOGRAPHY / SOURCES CONSULTED

- Hoogesteger, Paul A. Introduction to Material & Processes.
Rochester, NY: Privately printed, 1987.
- Hornsby, Al, Drew Richardson, and CK Stewart, eds. PADI Open Water Diver Manual.
Santa Ana, CA: PADI, 1990.
- Gasbarre, Dominic., dive instructor at RIT [Thesis Consultant].
Interview by author, 10 September 1991,
Rochester, NY. Notes. dive office at RIT.
- Plano, Joseph., dive instructor and owner of Aquatic Center dive shop.
Interview by author, 3 November 1991,
Rochester, NY. Notes. Aquatic Center, Rochester.
- Gray, Robert., executive director of Diving Equipment Manufacturers Association (DEMA).
Interview by author, 26 November 1991,
Tustin, CA. Phone interview. Rochester.
- Zigahn, Armand., executive vice president of Underwater Society of America.
Interview by author, 26 November 1991,
Daly City, CA. Phone interview. Rochester.
- Davison, Benjamin., editor of Undercurrent magazine.
Interview by author. 26 November 1991
New York, NY. Phone interview. Rochester.
- Torok, Joseph Dr. Ph.d., engineering professor at RIT [Thesis consultant].
Interview by author, 17 January 1992,
Rochester, NY. Notes. Mechanical engineering office, RIT.
- Iannone, Louis Sr., designer.
Interview by author, 19 January 1992,
Buffalo, NY. Notes. Iannone residence, Buffalo.
- Shaw, William., sales representative for Mitten Fluidpower.
Interview by author, 6 February 1992,
Rochester, NY. Notes, samples, brochures. Mitten Fluidpower, Rochester.
- Phelps, Douglas., sales executive for Rinky Dink Golf and Games.
Interview by author, 7 March 1992,
Rochester, NY. Phone interview, donation. RIT.
- French, Fred., welder.
Assisted in construction, 14 March 1992,
Rochester, NY. Welded steel, advised on construction. French residence, Rochester.



APPENDIX I

COLOR IMAGES

3-D COMPUTER GENERATED IMAGES	46
PHOTOS	50
HAND RENDERING	51

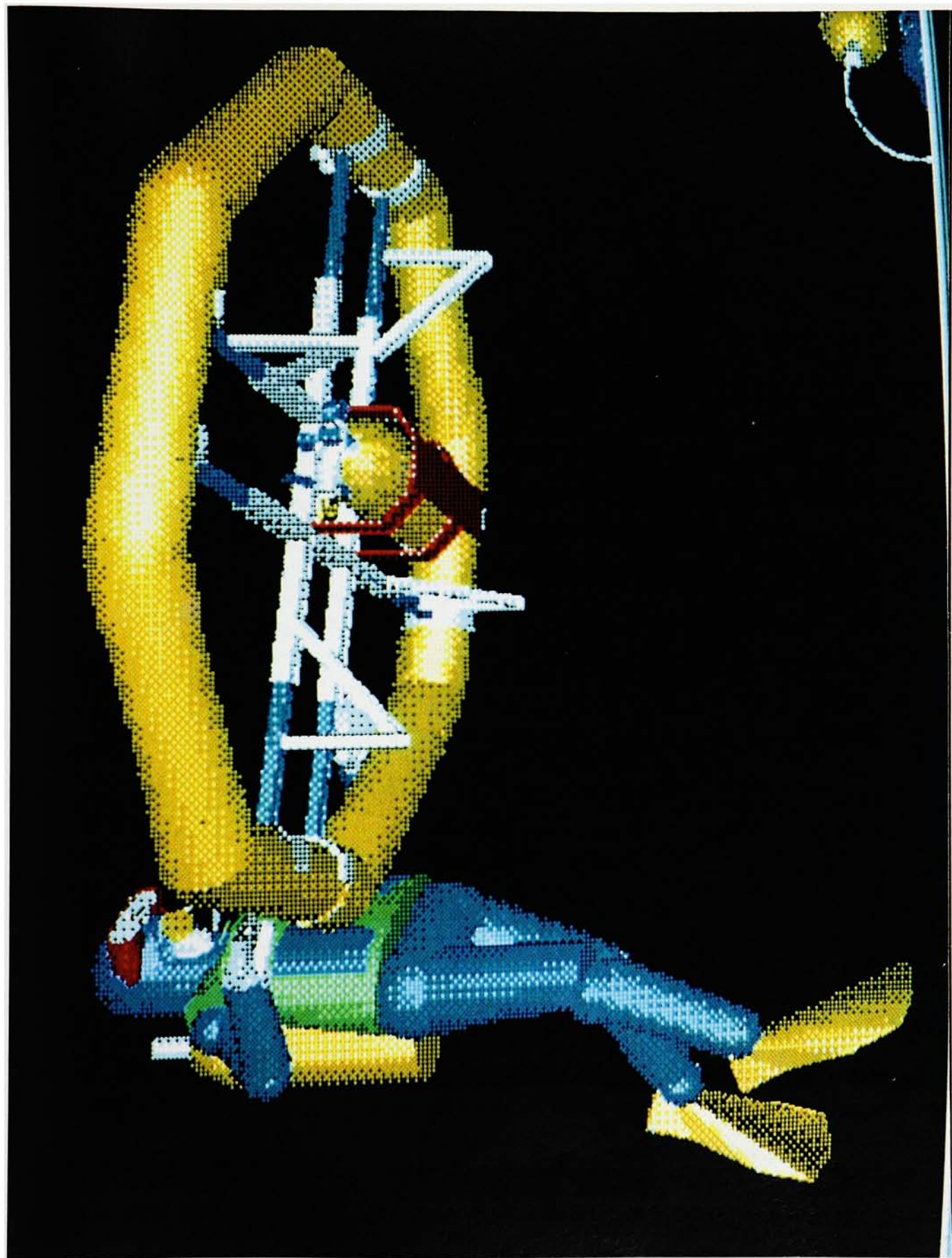

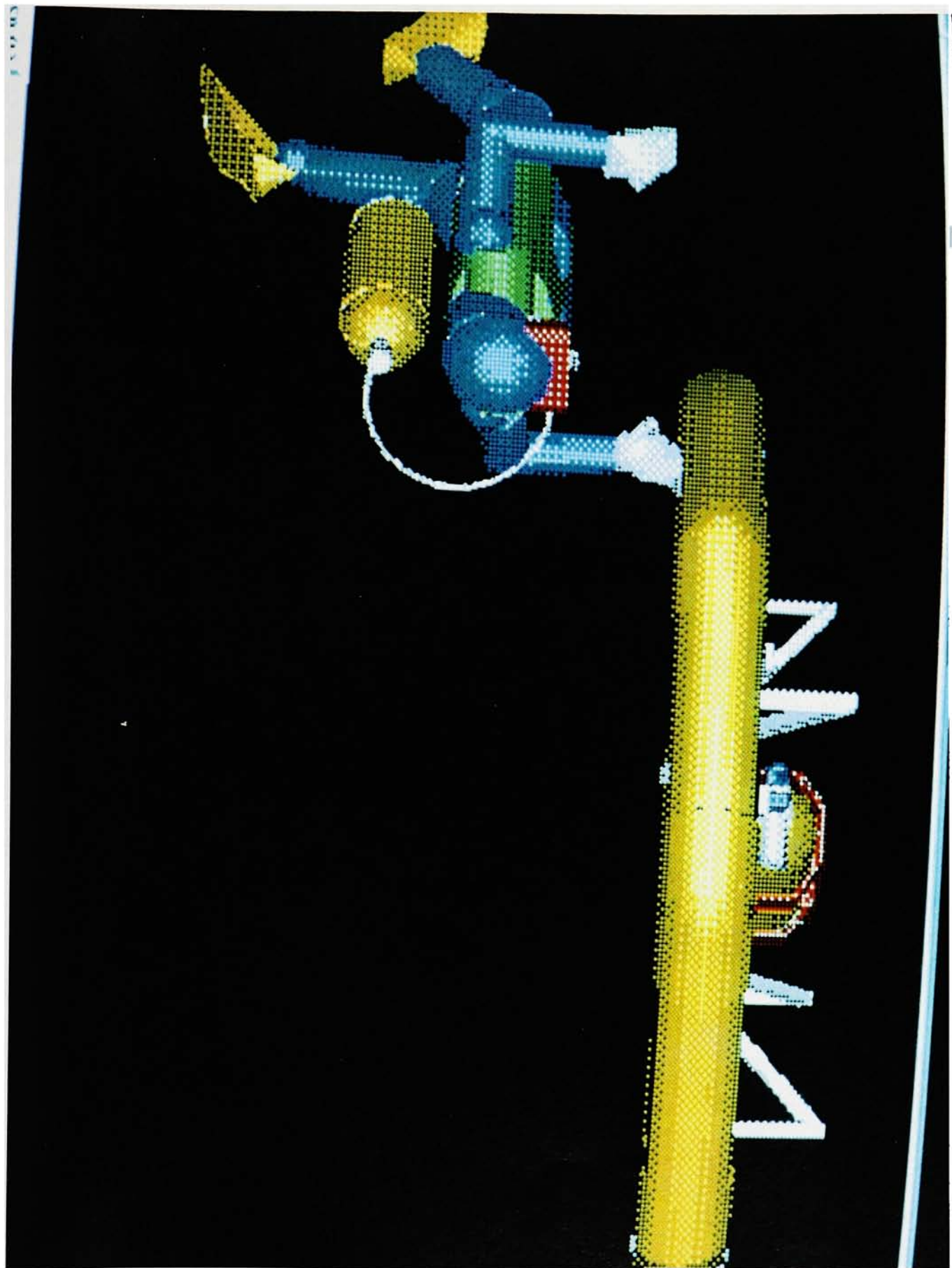

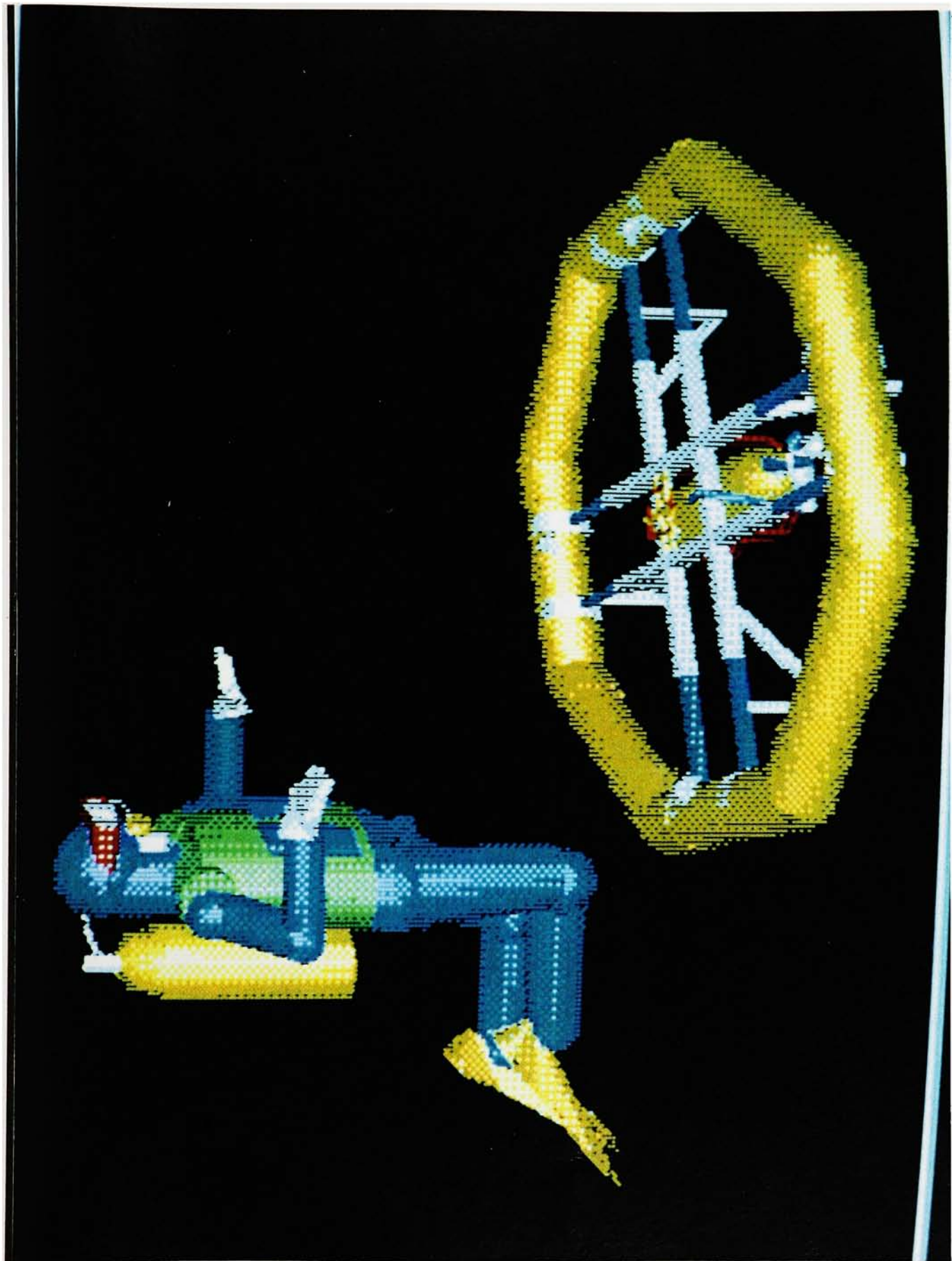

View 2-130

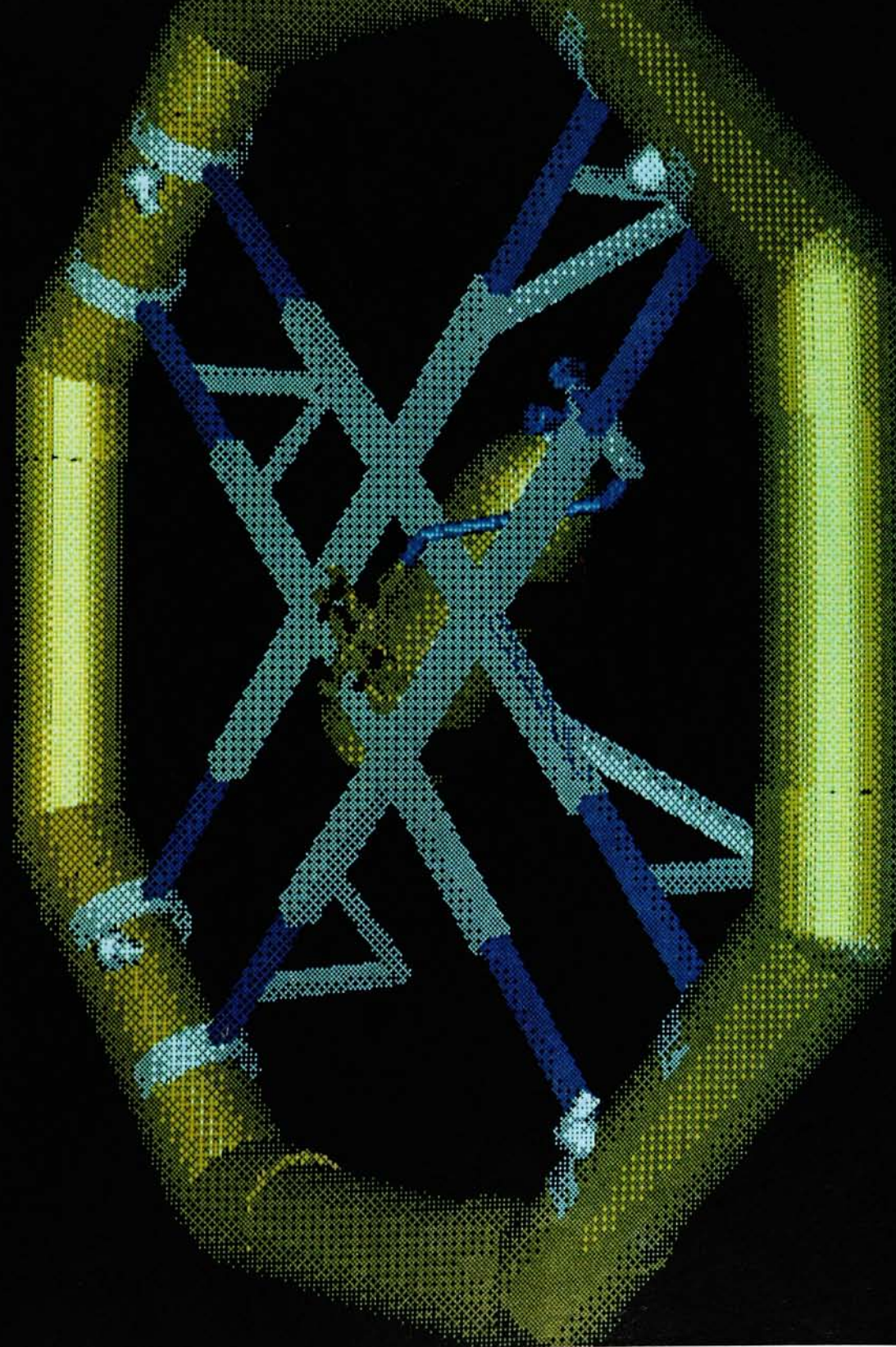



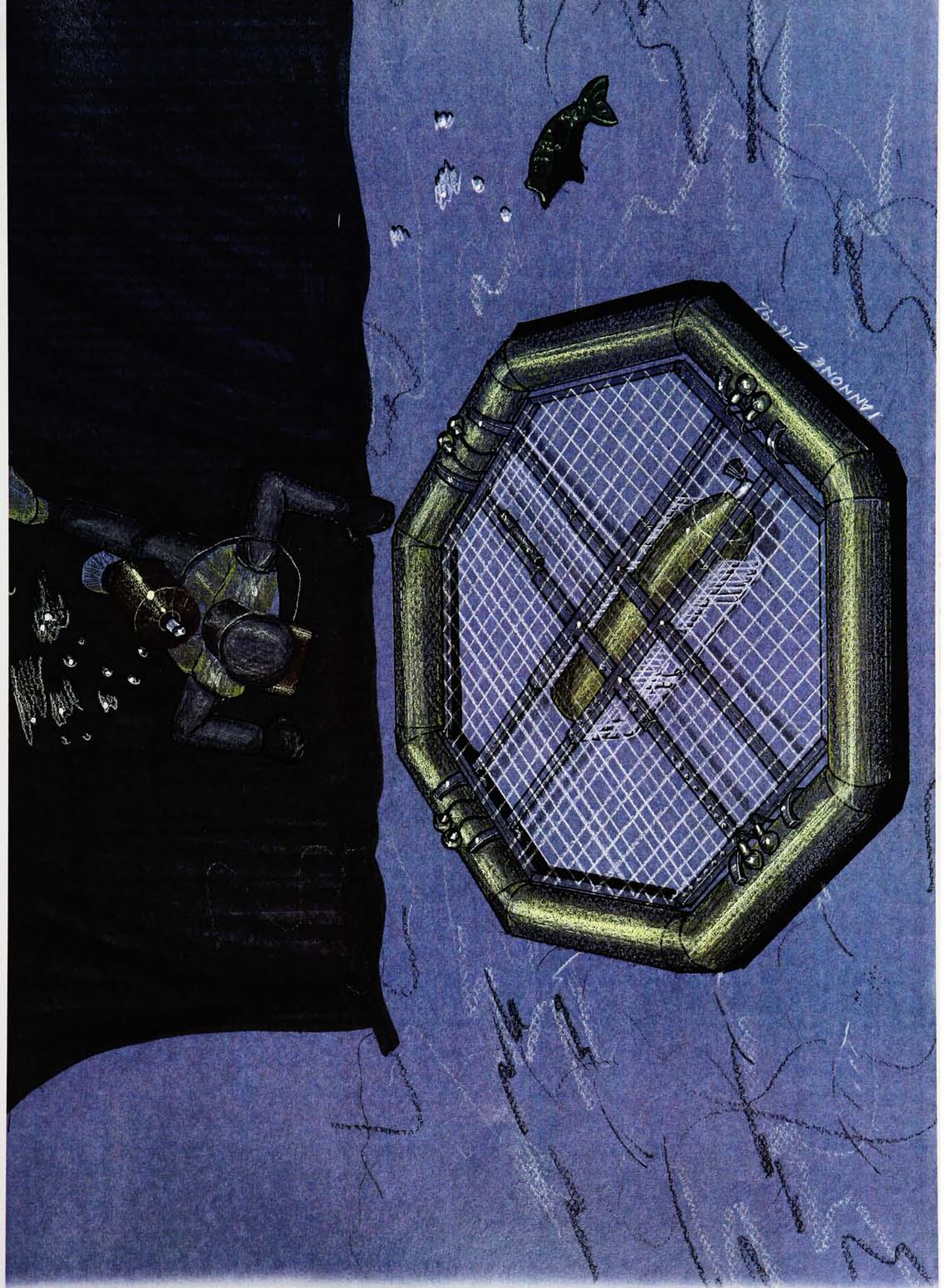



APPENDIX II

CONCEPTION AND FORMATION OF DESIGN

BEGINNING CALCULATIONS	53
INITIAL SKETCHES	55

1728

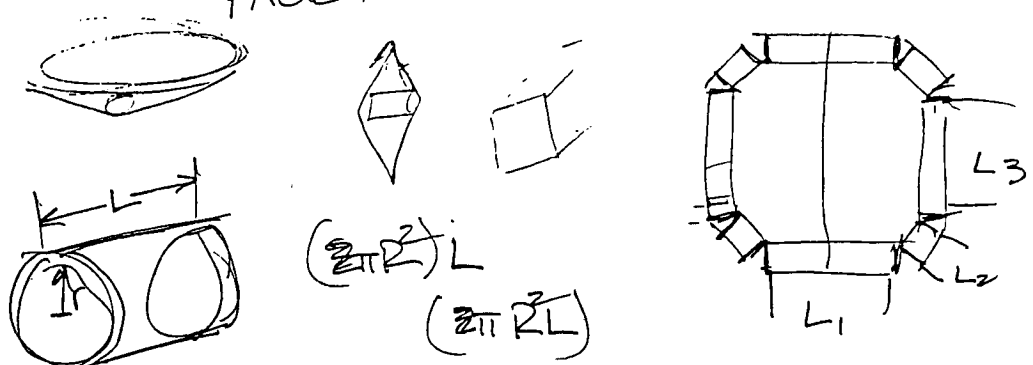

1036 lbs.
13 in H₂O

$$V_{OL_TOTAL} = 2(\sum \pi R_i^2 L_i) + 2(\sum \pi R_i^2 L_i) + 2(\sum \pi R_i^2 L_i)$$

144 lbs.
filled

$$V_{OL_TOTAL} = 2\pi(R_1^2 L_1) + 4\pi(R_2^2 L_2) + 4\pi(R_3^2 L_3)$$

$$V_{OL_TOTAL} = 2\pi[(R_1^2 L_1) + (R_2^2 L_2) + (R_3^2 L_3)]$$

$\pi = 3.14$

LET $R_1 = R_2 = R_3 = 6$ in
 $L_1 = L_2 = L_3 = 2$ FT = 24 IN

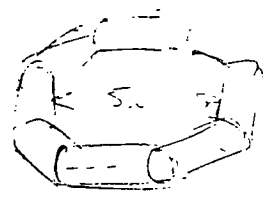

$2\pi R = C$
 $\pi R^2 = A$
 $\pi R^2 \times L = V$
 $W = V = \text{Density}$

FOR OCTAGON $V_T = 2\pi[(R^2 L) + (R^2 L) + (R^2 L)]$
 $2\pi[3(R^2 L)]$

$V_T = 2\pi(3R^2 L)$
 $V_T = 5426 \text{ in}^3$
 $(V_T = 4,069.44)$

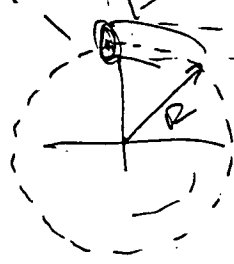

$(\pi R^2) \times 2\pi R = V_{TOTAL \text{ CIRCULAR}}$
 $(\pi 3^2) \times 2\pi(36)$

6,389 in³
 5,857

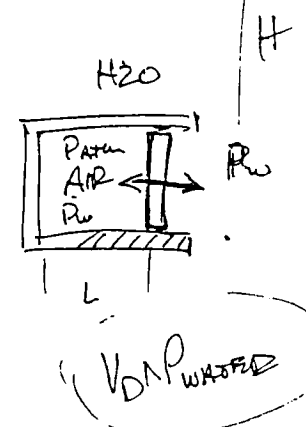
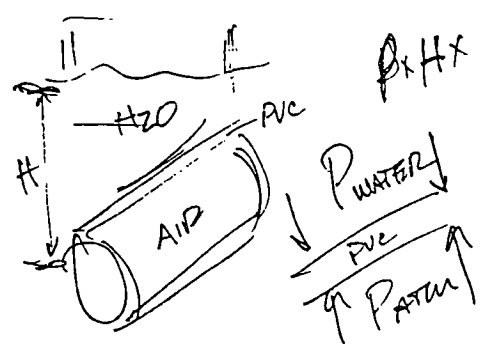

-Initial calculations on volume of cylinders

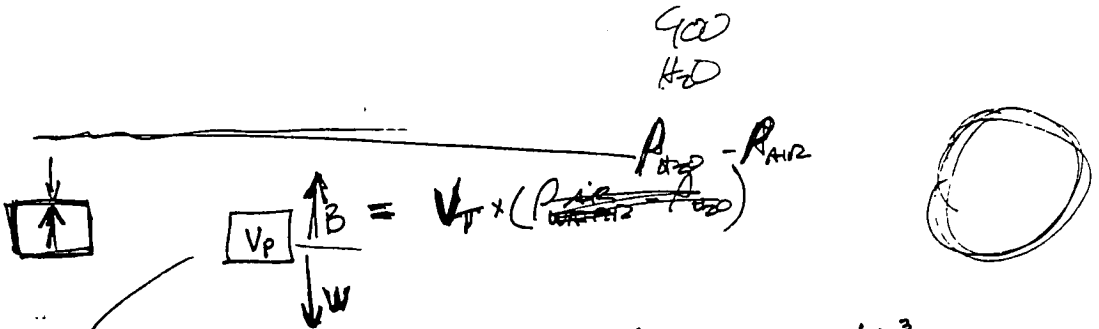

$V_{max} = 4000 \text{ in}^3$
 $V_{min} = 0$

$$B = V_T \times (\rho_{air} - \rho_{air})$$

$$W = V_T (\rho_D)$$

$$w = (4000 \text{ in}^3) \left(\times \frac{160}{\text{in}^3} \right)$$

4 in^3

$$w = 1000$$

$$w = 5,000$$

$$200 = (V) (.25)$$

$$V = 800 \text{ in}^3$$

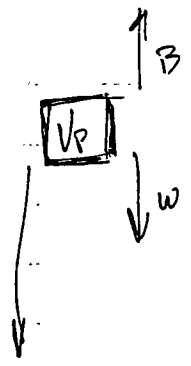

-Initial calculations on weight versus buoyancy

PAUL HOGY.

~~XXXXXXXXXX~~

THURS. 8.

11-5-91
DOMI GASPARI
45 min.

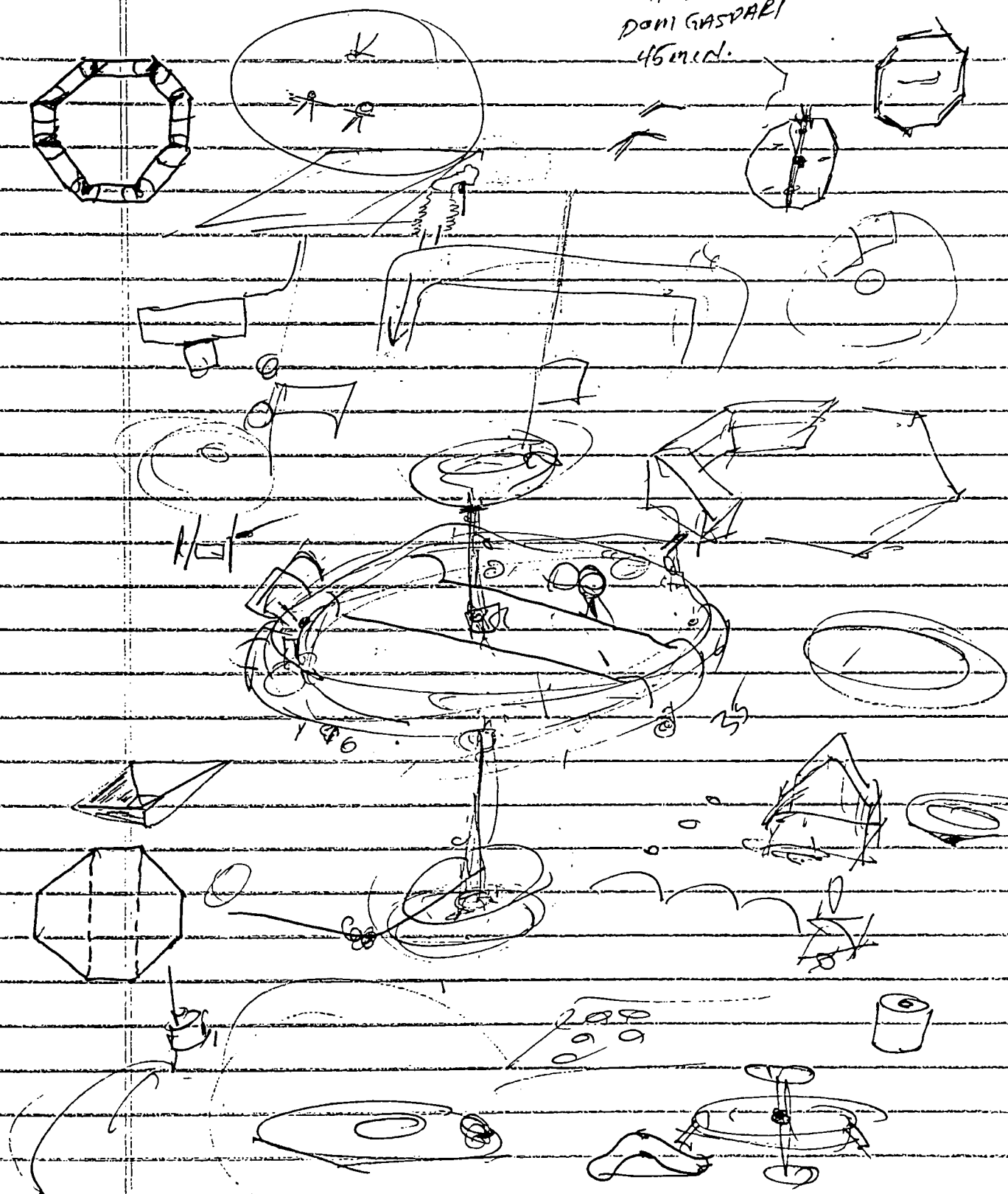

-Initial ideation sketches with
thesis consultant Dominic Gasbarre

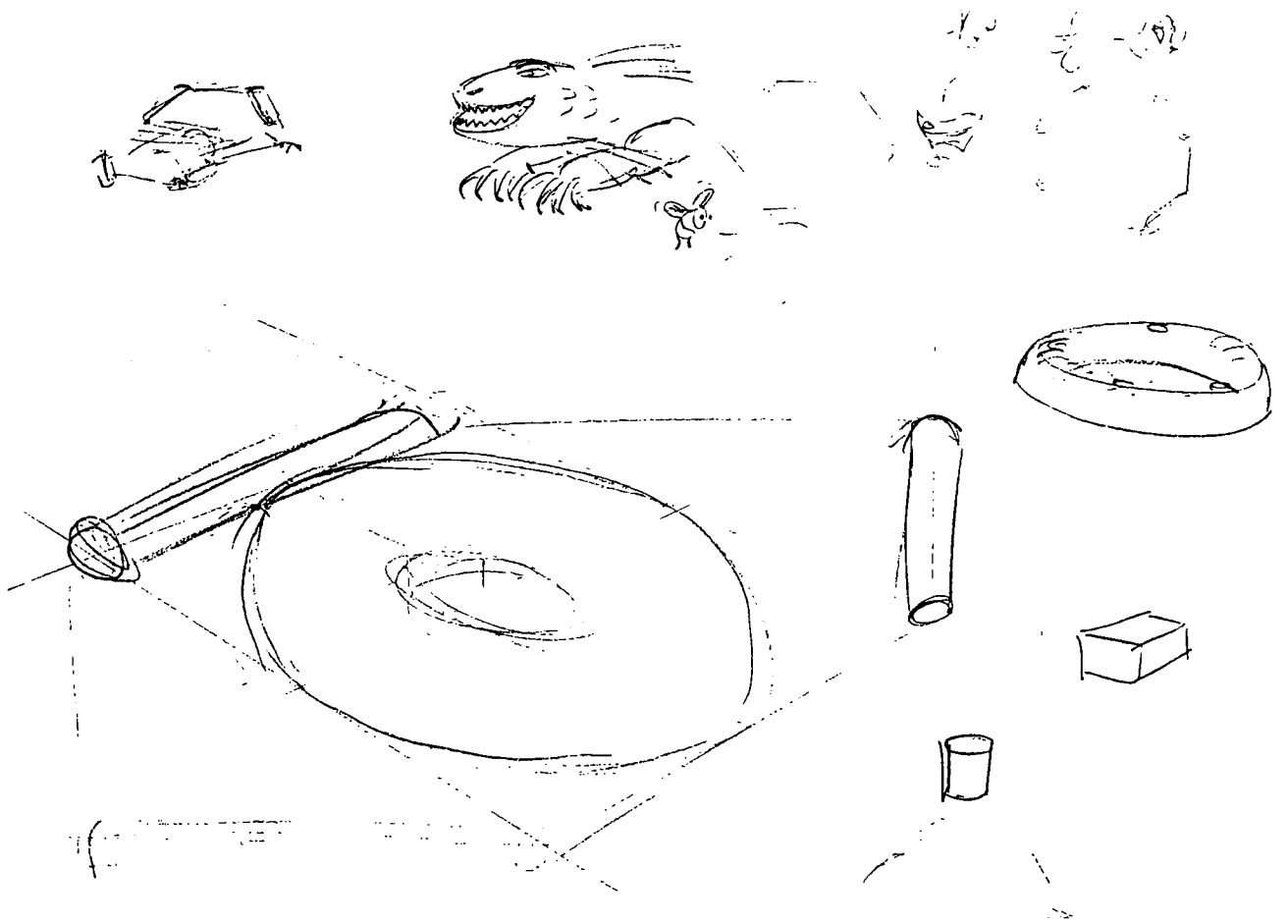

-Ideation sketch, circular format
versus rectangular

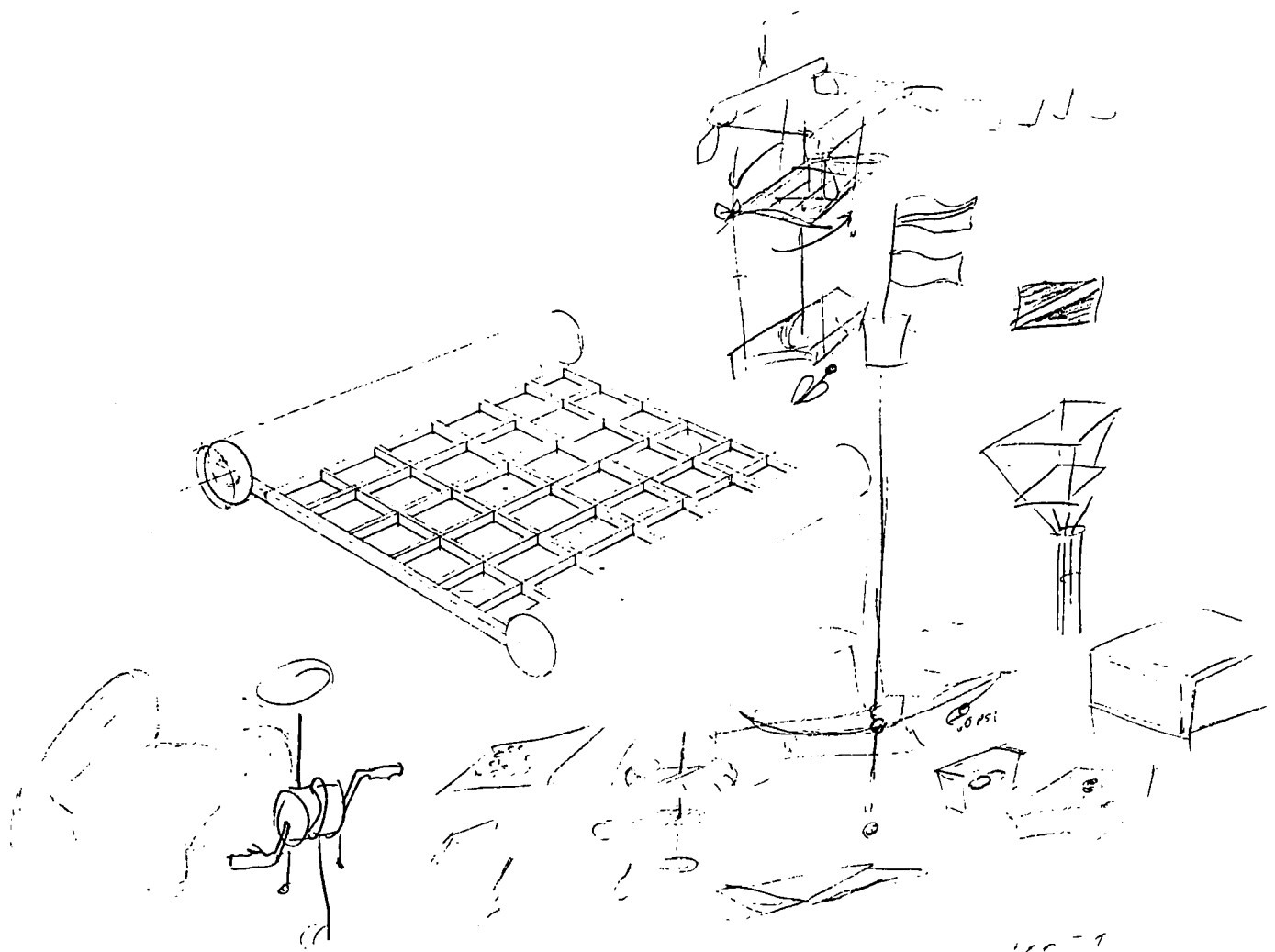

-Ideation sketch of rectangular format
reference to use of dive flags and anchor winch

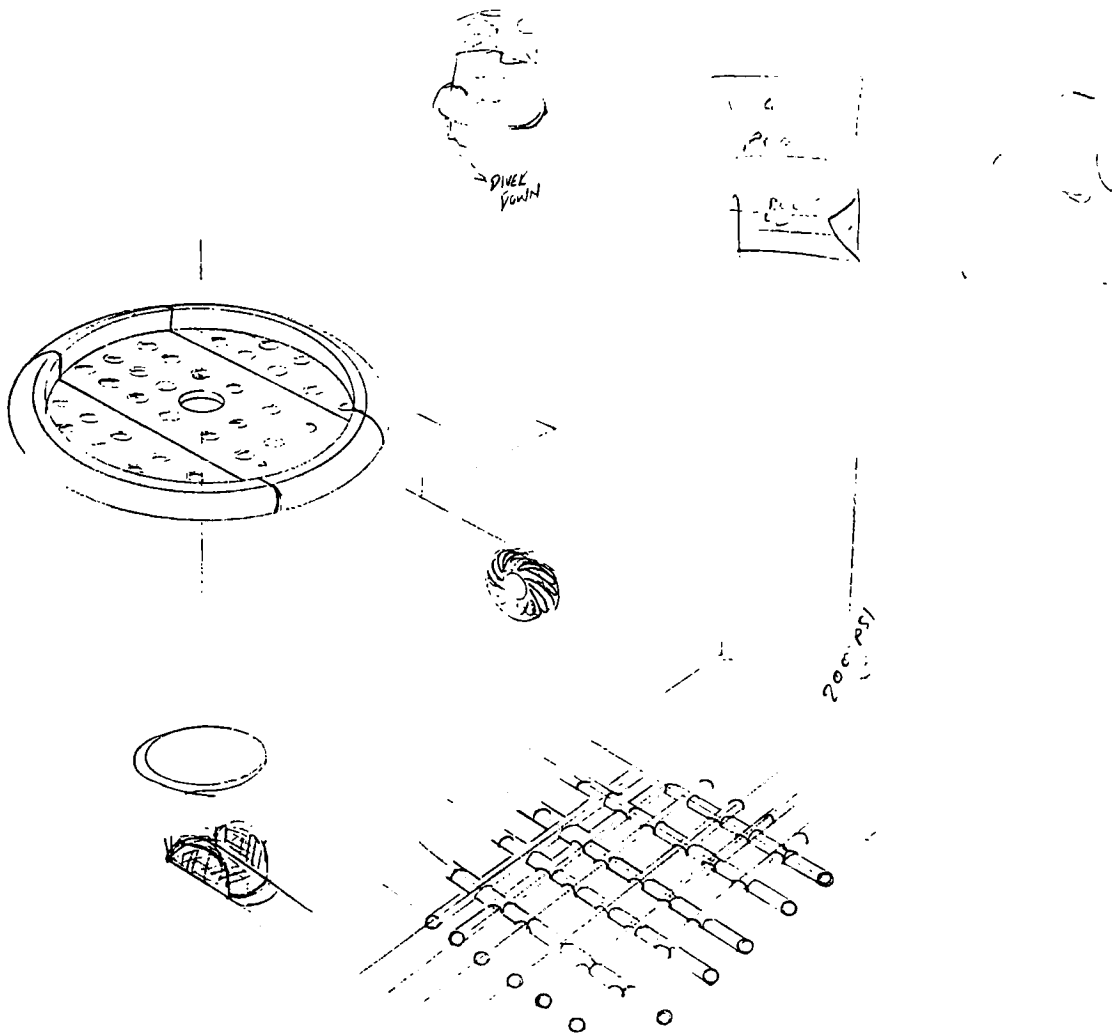

-Ideation sketch of circular format with reference to mesh / grating and folding dock concept

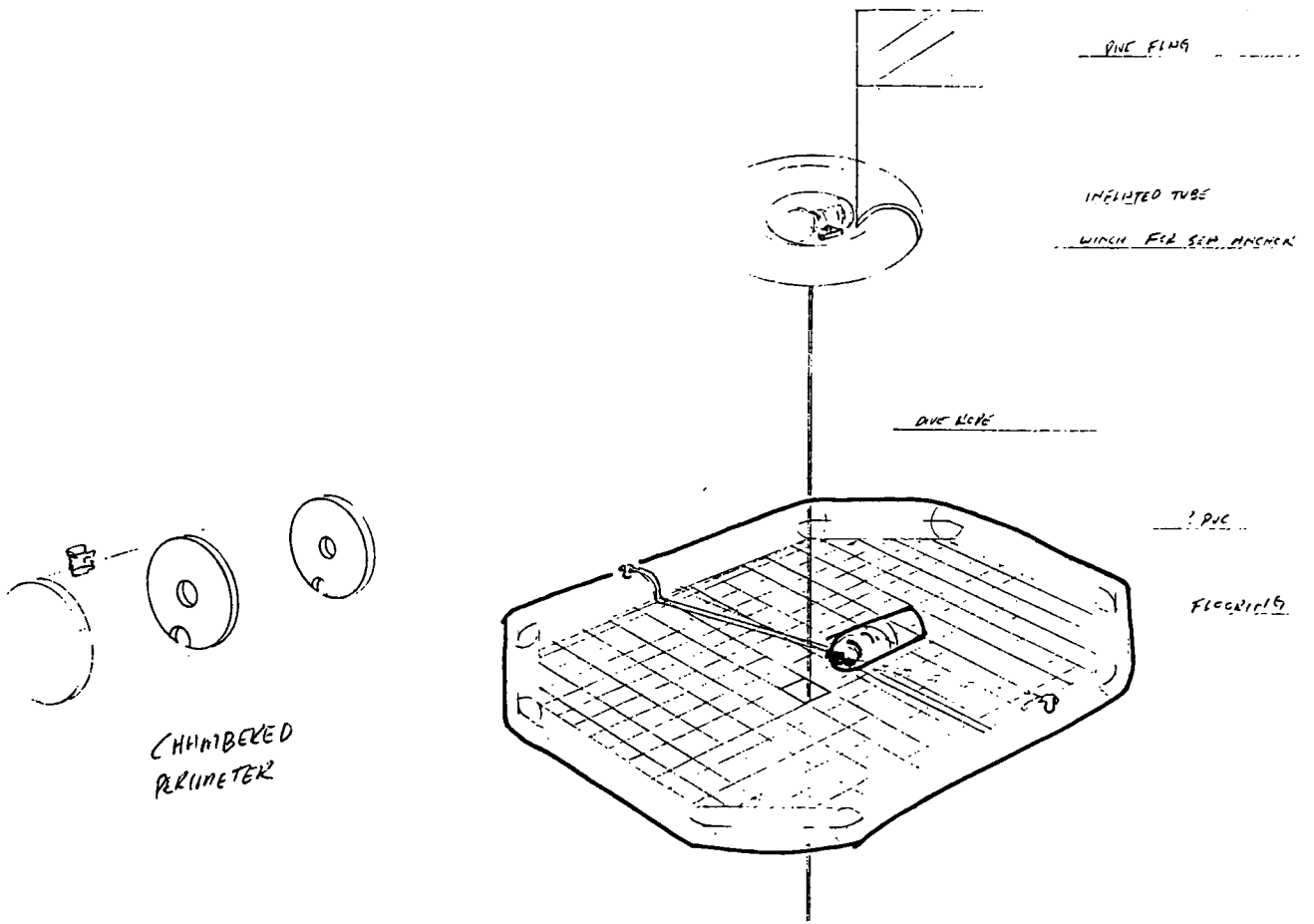

-Ideation sketch of octagonal format with reference to chambered perimeter



APPENDIX III

COMPUTER AIDED DESIGN

ERGONOMIC DIVER	61
CAD IDEATION SKETCHES AND RENDERINGS	62
GRAPHIC DESIGN DEVELOPMENT	77
SALES SHEET DESIGN	80

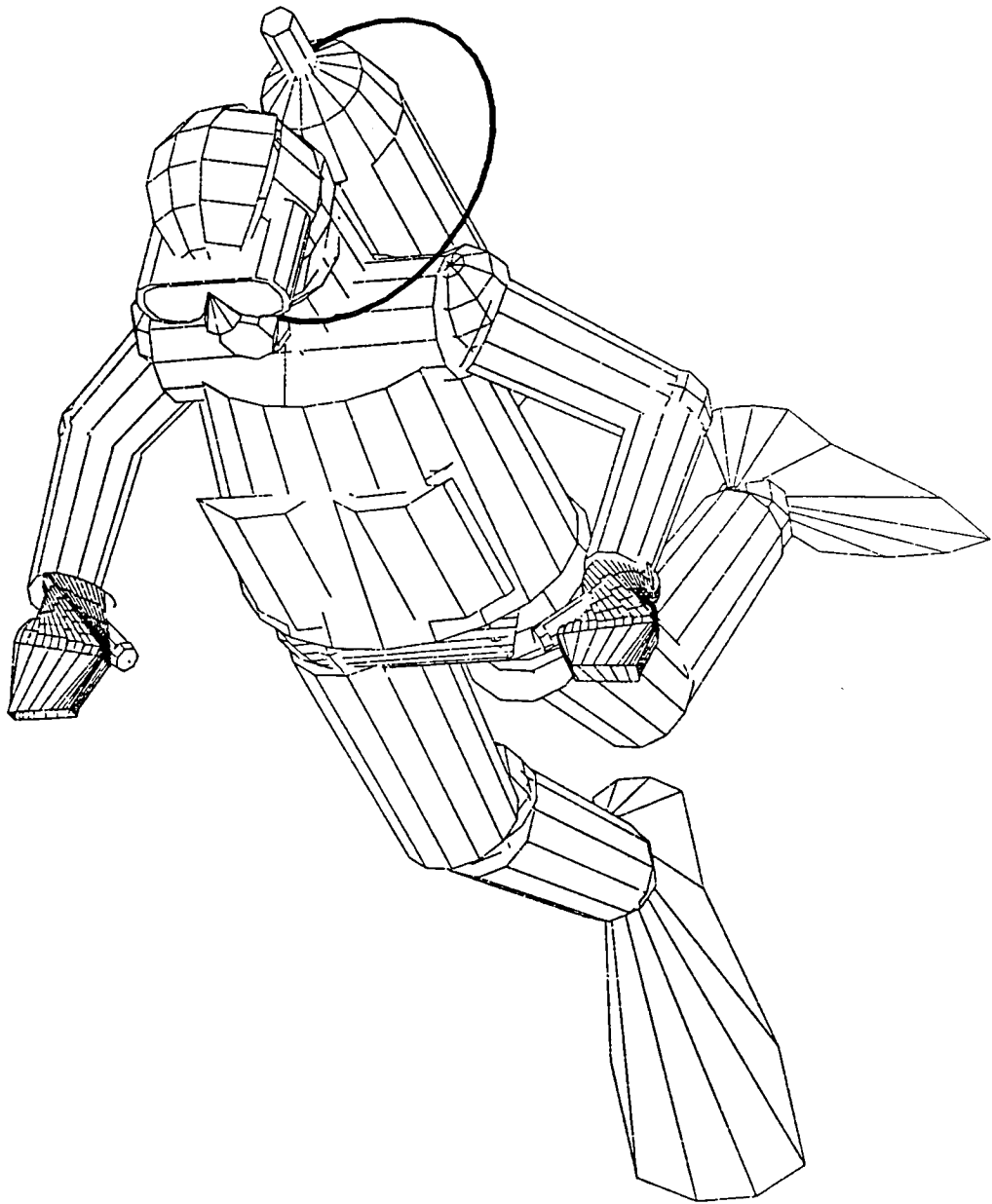

**CAD sketch: hidden line perspective
-ergonomic diver**

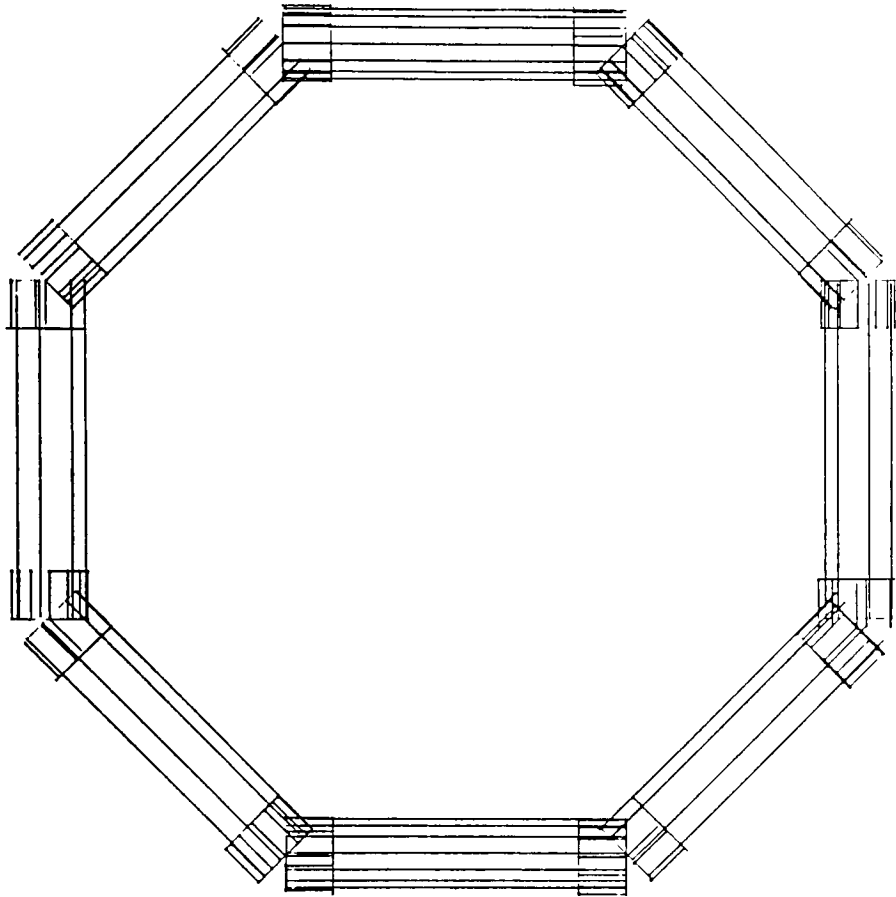

b:\lou0212.dgn May. 20, 1992 10:19:51

**CAD sketch: skeleton top view
-octagonal perimeter**

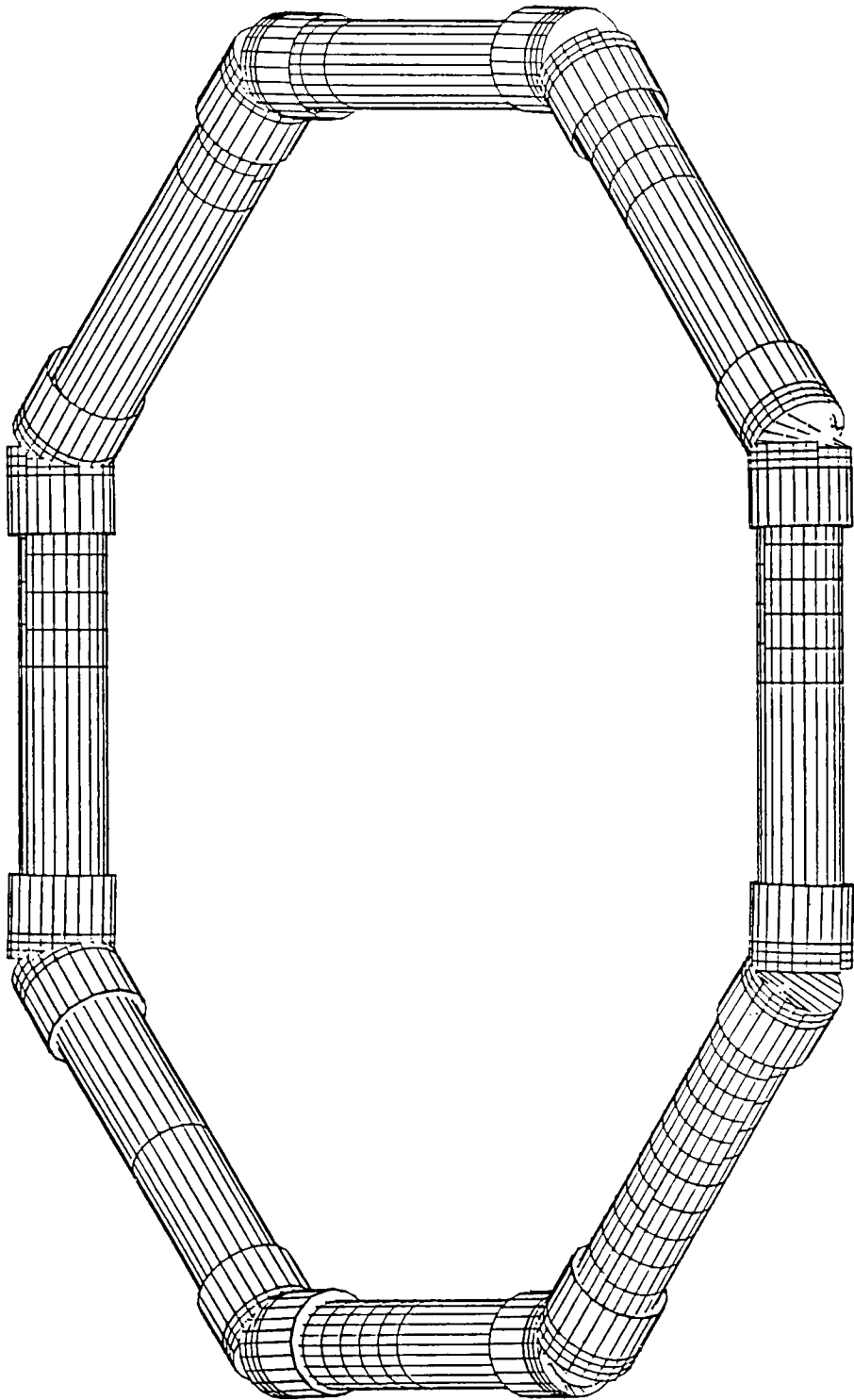

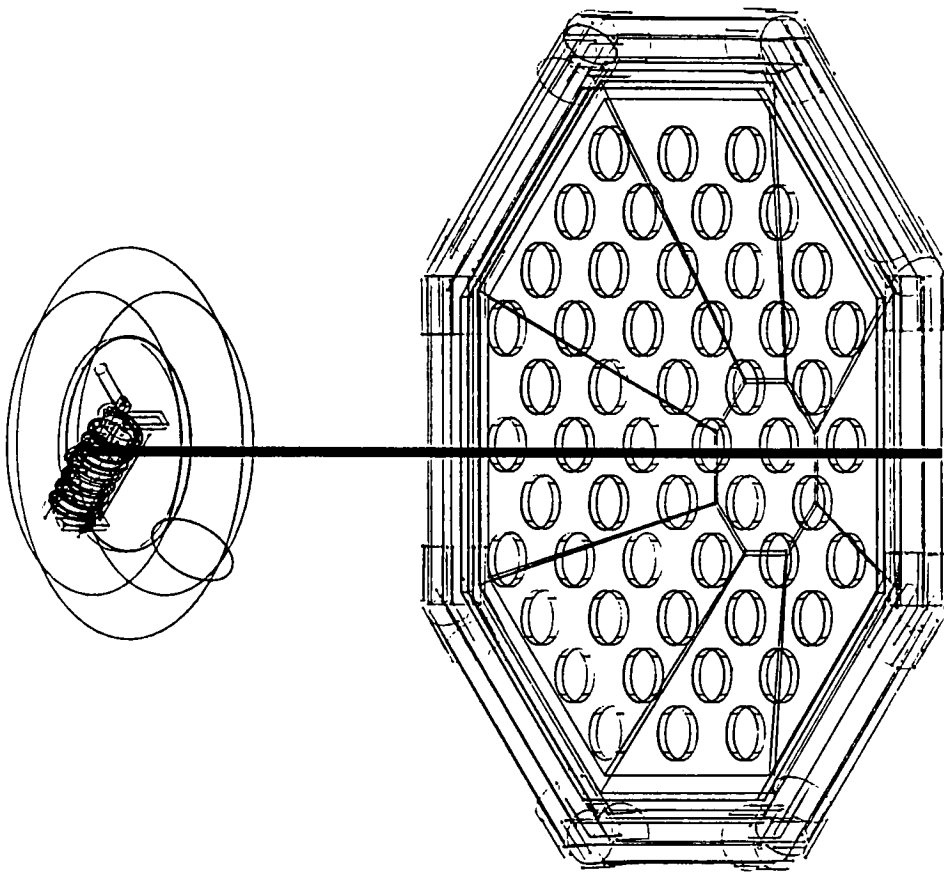

b. \low1211.dgn May. 20, 1992 11:11:55

- CAD sketch: skeleton perspective**
- octagonal platform
 - perforated platform base
 - inverted cone bottom to centralize weight
 - dive float equipped with line winch

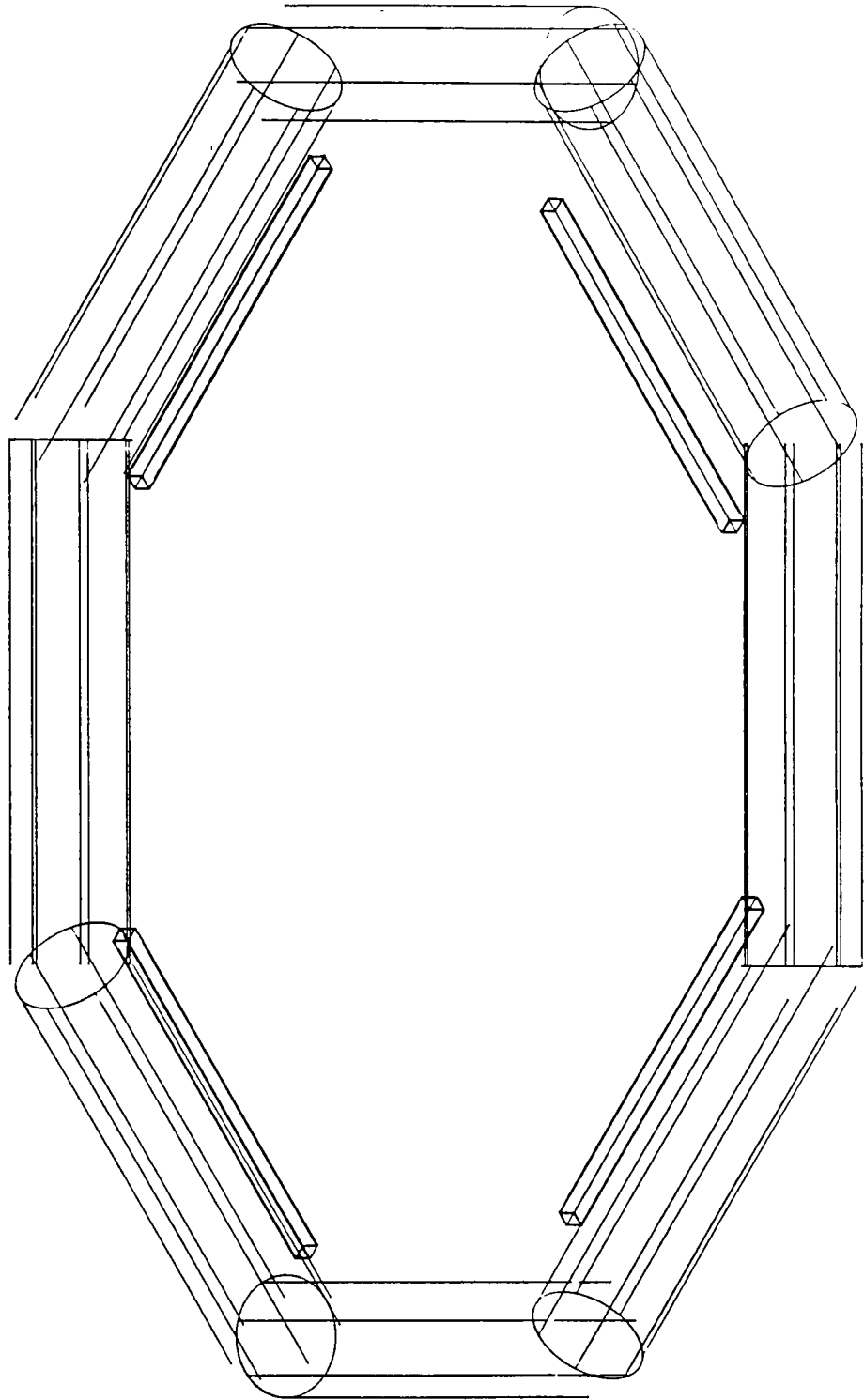

CAD sketch: skeleton perspective
- octagonal perimeter
- bar concept of how to attach nylon mesh base

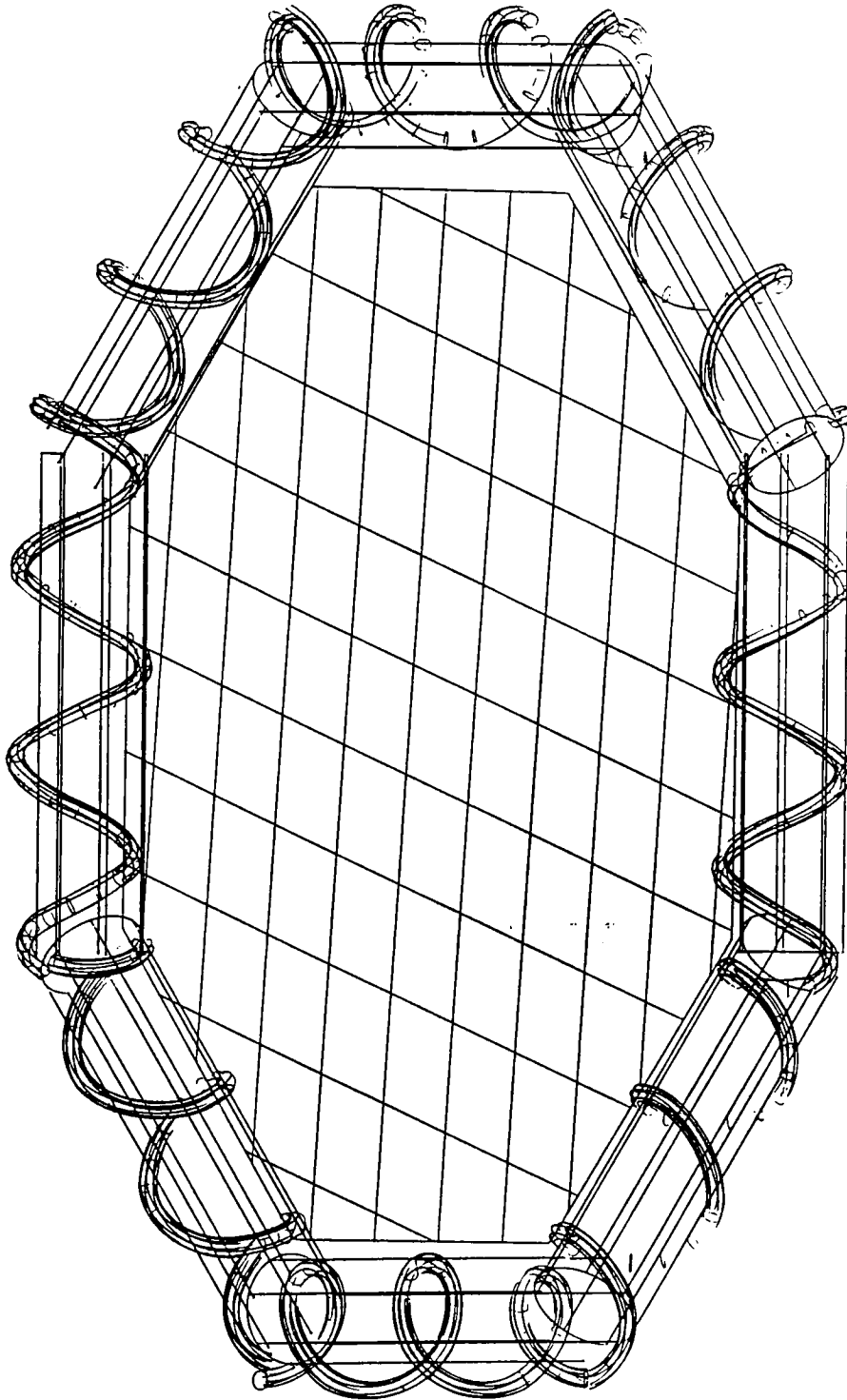

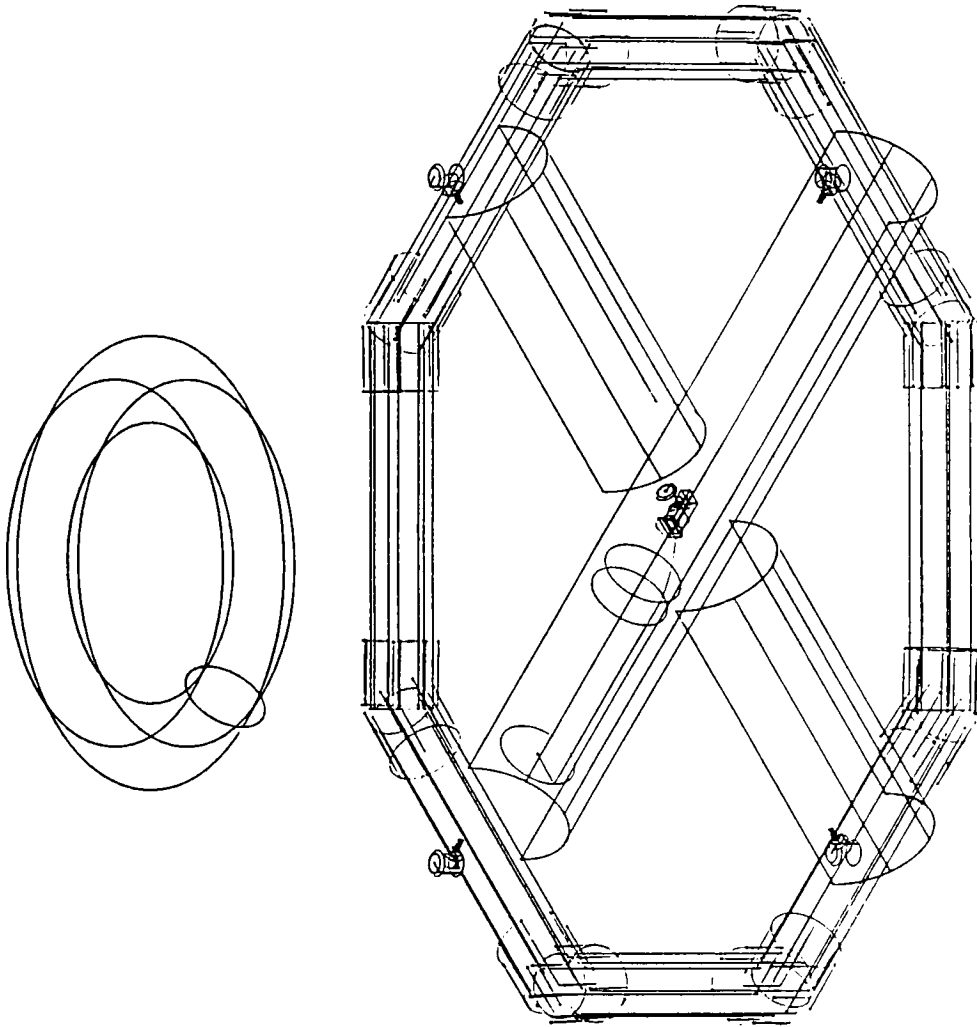

b:\lou0114b.dgn May. 20. 1992 11:05:35

- CAD sketch: skeleton perspective**
- octagonal perimeter with elbows
 - half tube concept for static footing
 - top of perimeter placement of valves
 - placement of tank in footing sections
 - dive float

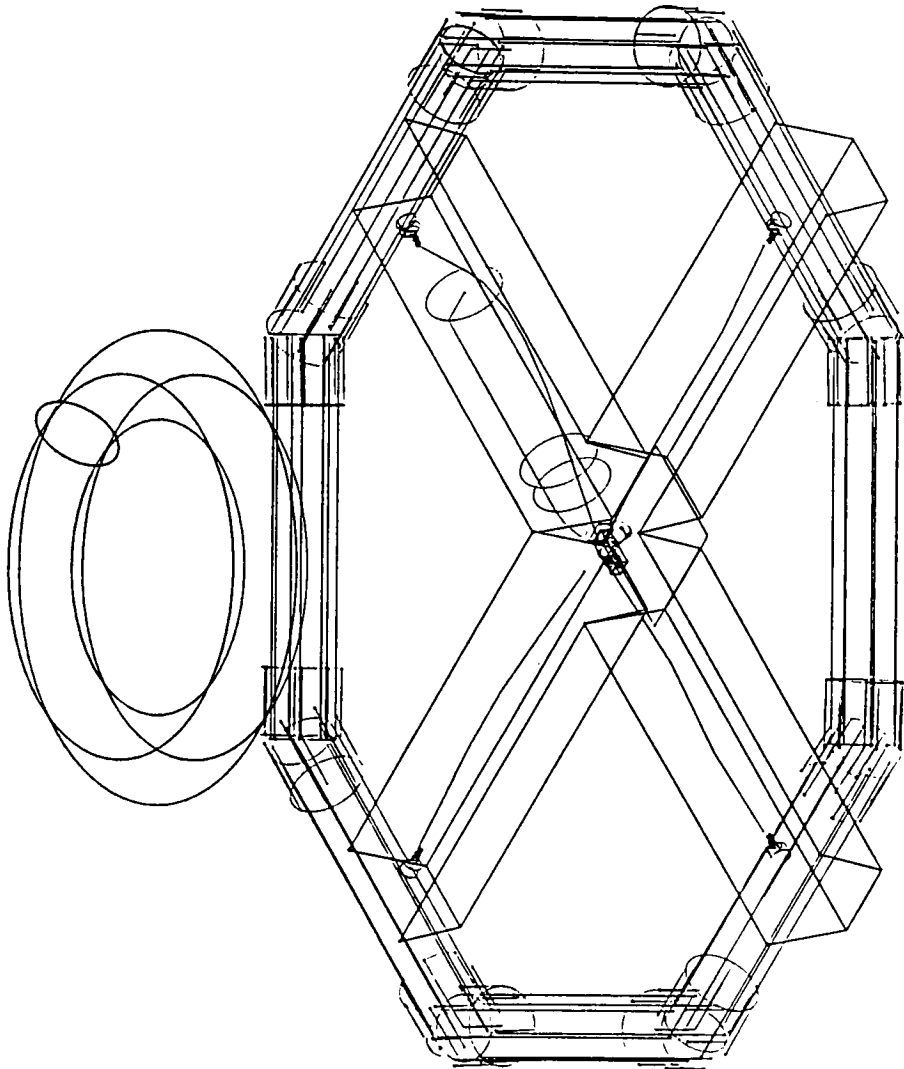

b. \lou0114.dgn May. 20, 1992 11:03.52

- CAD sketch: skeleton perspective**
- octagonal perimeter with elbows
 - boxed concept for static footing
 - placement of tank in footing
 - placement of valves inside perimeter
 - dive float

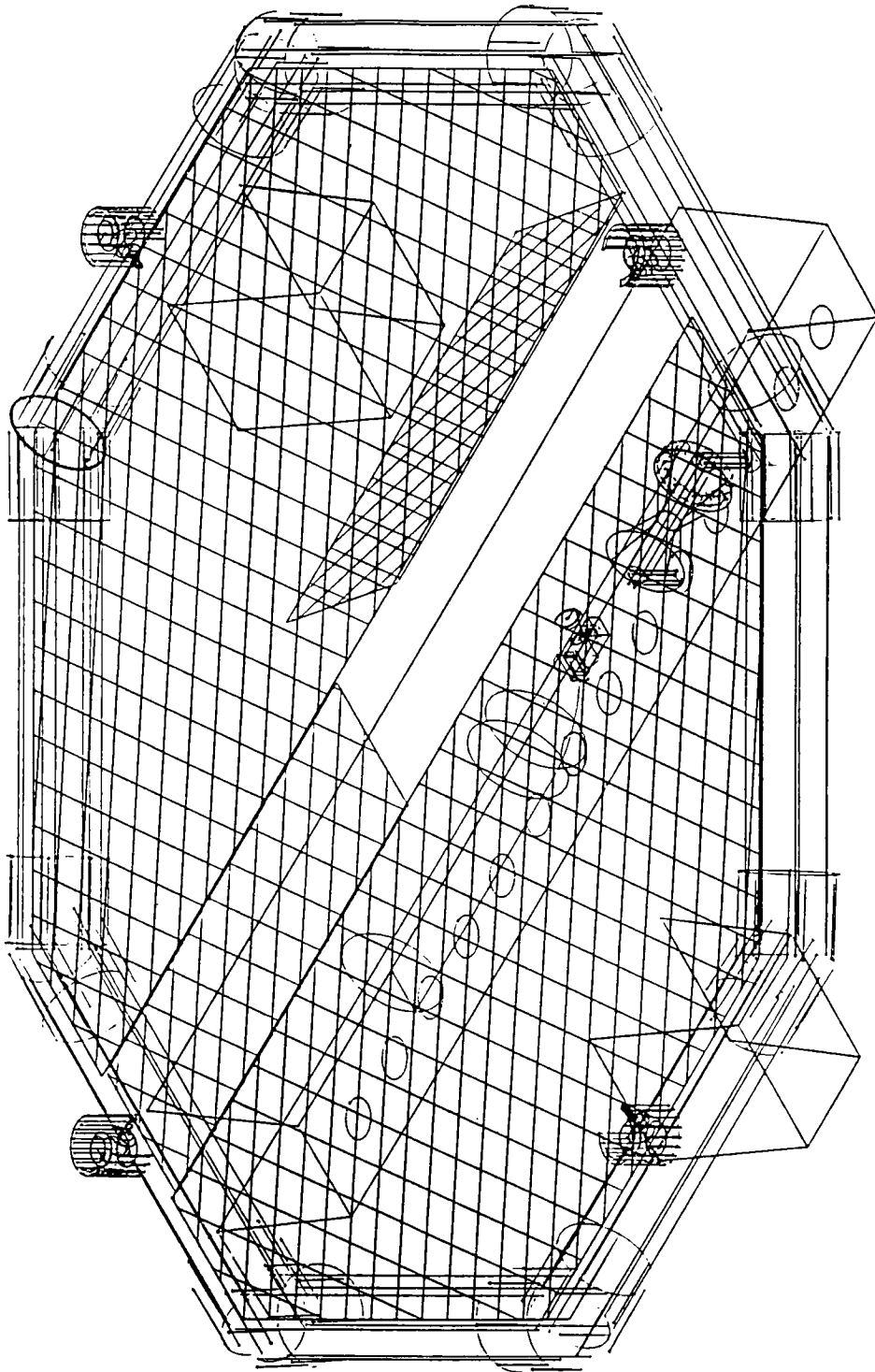

b:\lou0116.dgn May. 20. 1992 11:07:03

CAD sketch: skeleton perspective

- octagonal perimeter with elbows
- top of perimeter placement of valves with guards
- half box static footing concept
- static mesh with tank access flap concept
- placement of tank in static boxed footing
- dive float, cable winch concept

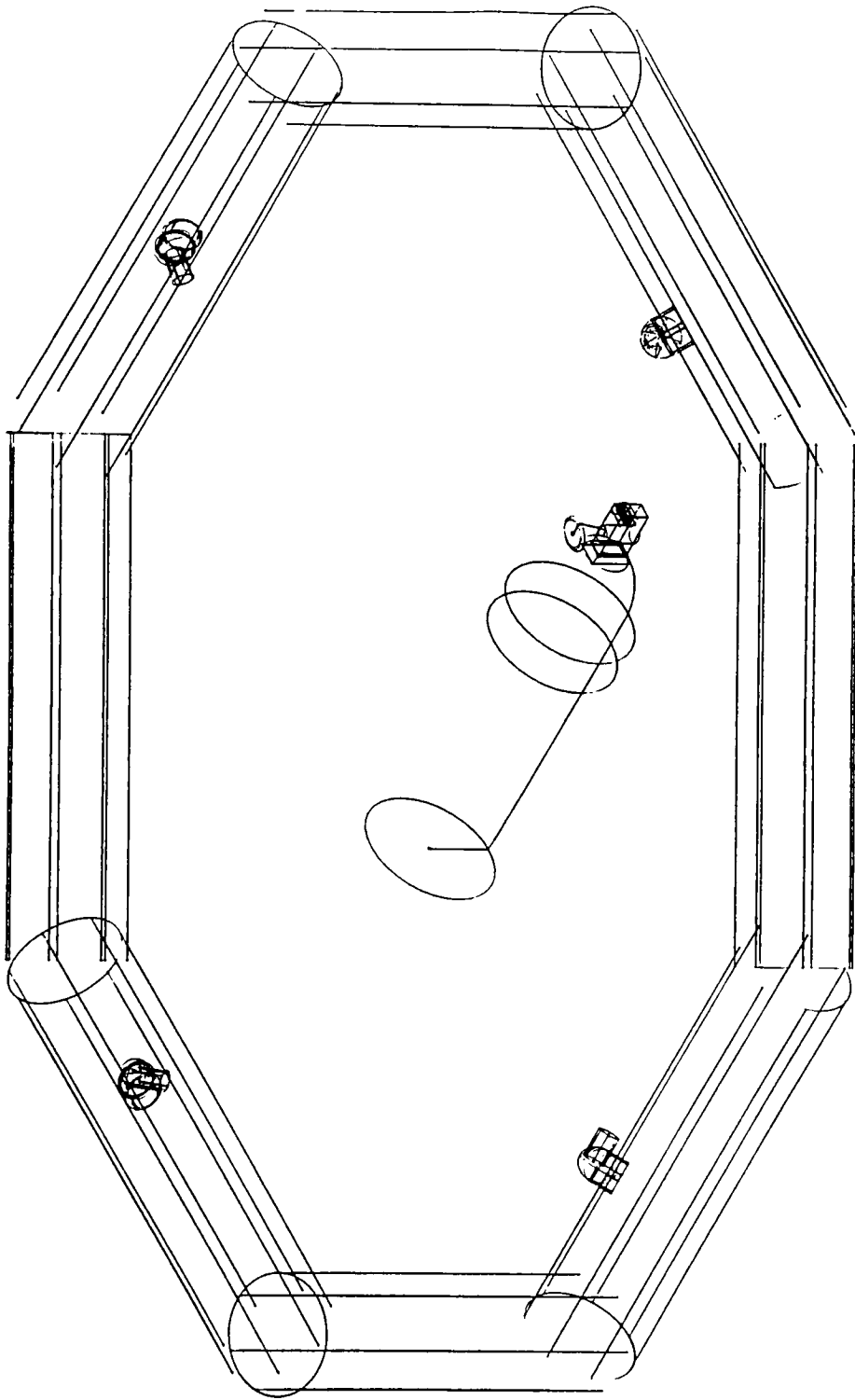

c:\cad\micro\dgn\loufinal.dgn May. 20, 1992 10.50.25

CAD sketch: skeleton perspective
- octagonal perimeter
- placement of tank
- rotated valving on inside of perimeter

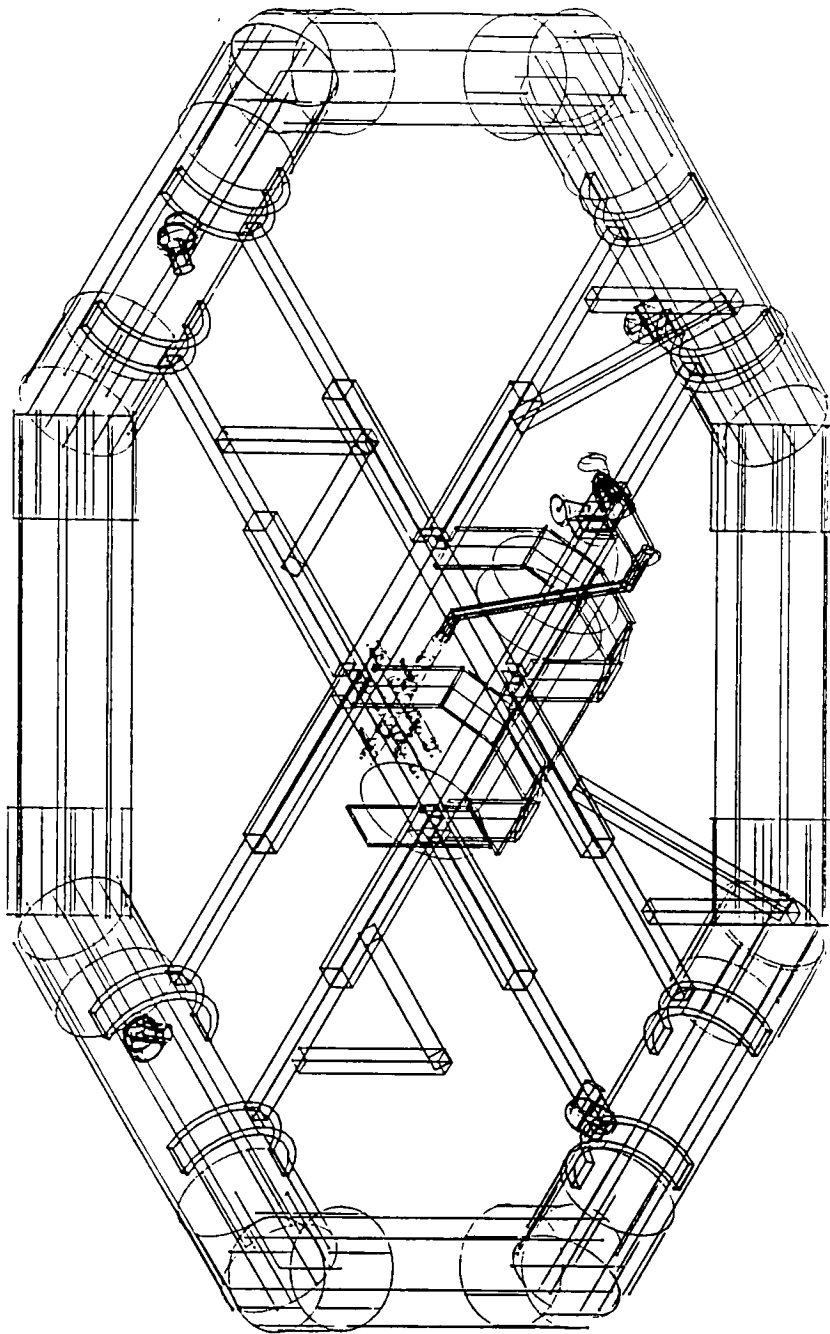

b:\lou0318.dgn May. 20, 1992 10:25:25

- CAD sketch: skeleton perspective**
- octagonal perimeter with elbows
 - double cross center support with angled legs
 - rotated valving on inside of perimeter
 - tank saddle
 - placement of tank in saddle
 - central valving and connection to tank

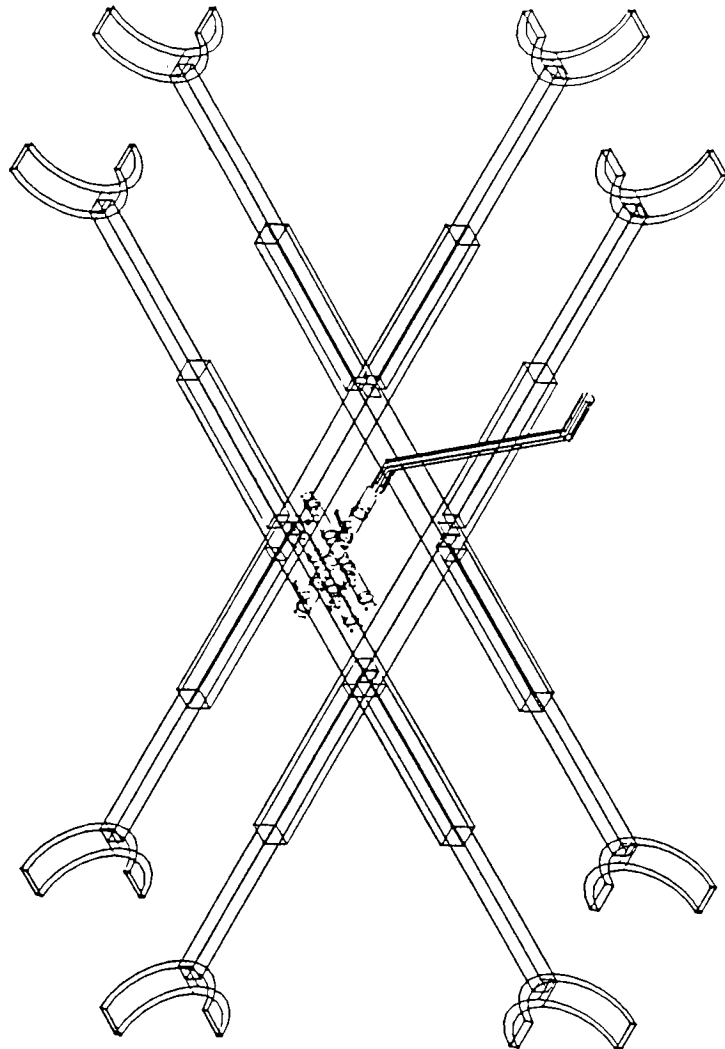

c:\cad\micro\dgn\loufinal.dgn May. 20, 1992 10:44:11

CAD sketch: skeleton perspective
- center support without legs
- central valving placement with hose

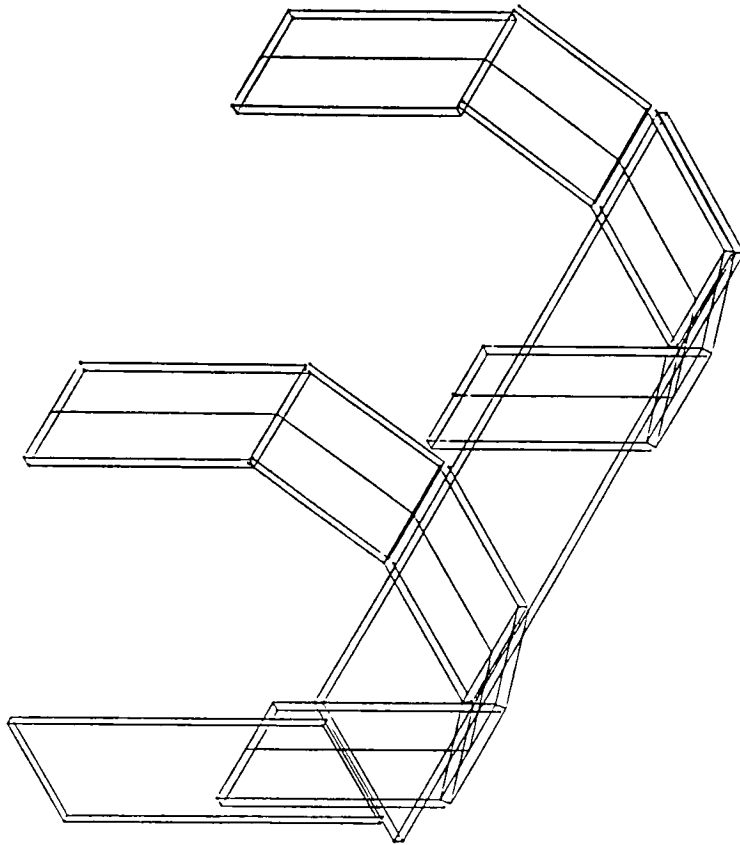

c:\cad\micro\dgn\loufinal.dgn May. 20, 1992 10:55:02

**CAD sketch: skeleton perspective
- tank saddle**

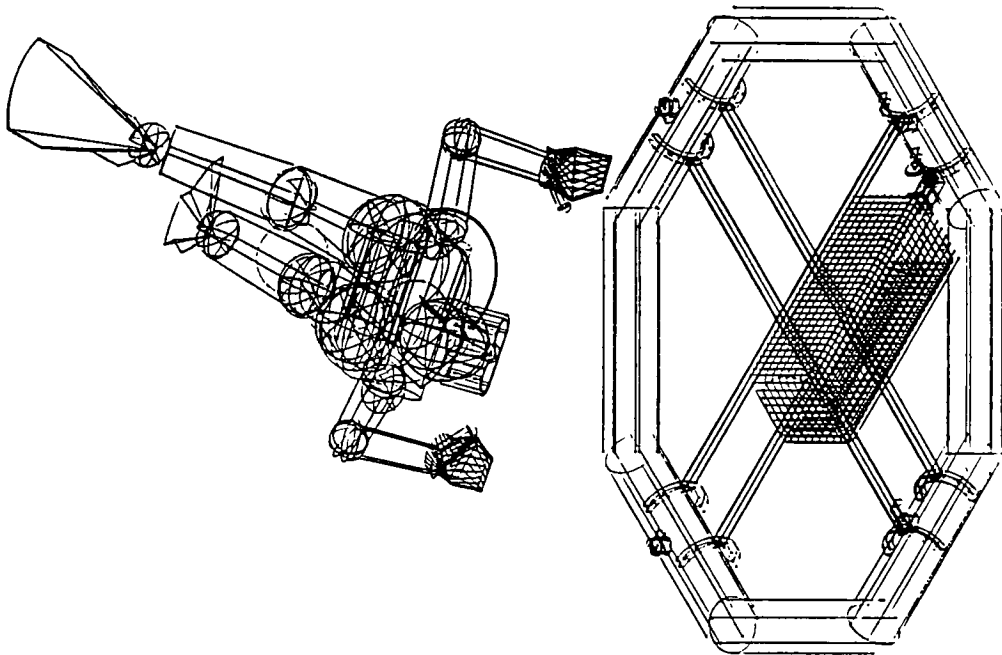

b. \lou0203.dgn May, 20, 1992 11:30:35

CAD sketch: skeleton perspective
- octagonal perimeter
- tank basket concept
- double cross center support
- top of perimeter valving
- skeleton of ergonomic diver

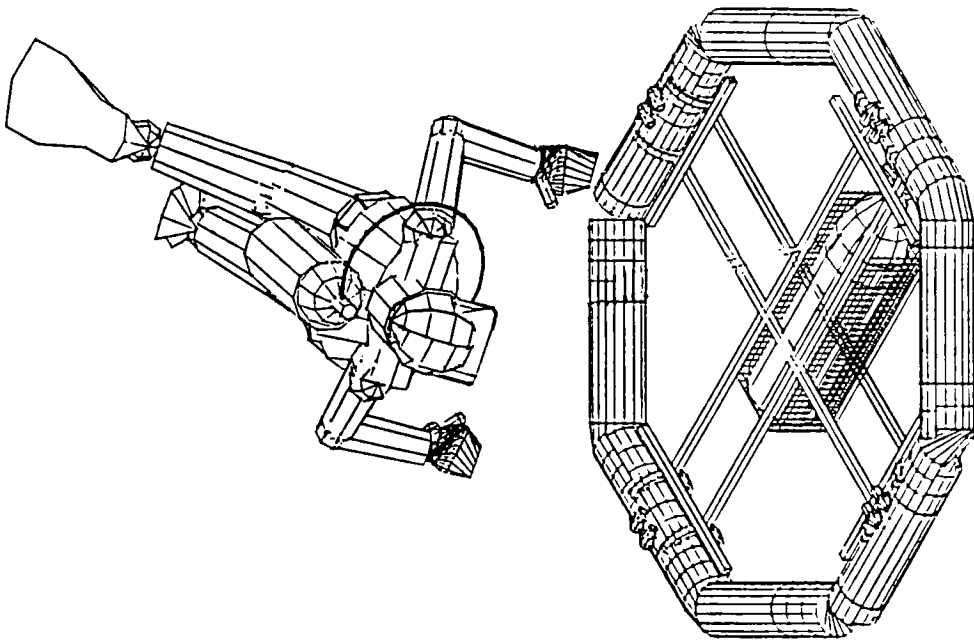

b:\lou0203.hin May. 20. 1992 10:10:21

CAD sketch: hidden line perspective

- octagonal perimeter
- double valving on top of perimeter concept
- double cross center support
- tank basket concept
- placement of tank in basket
- bar concept of where to attach wire mesh
- ergonomic diver

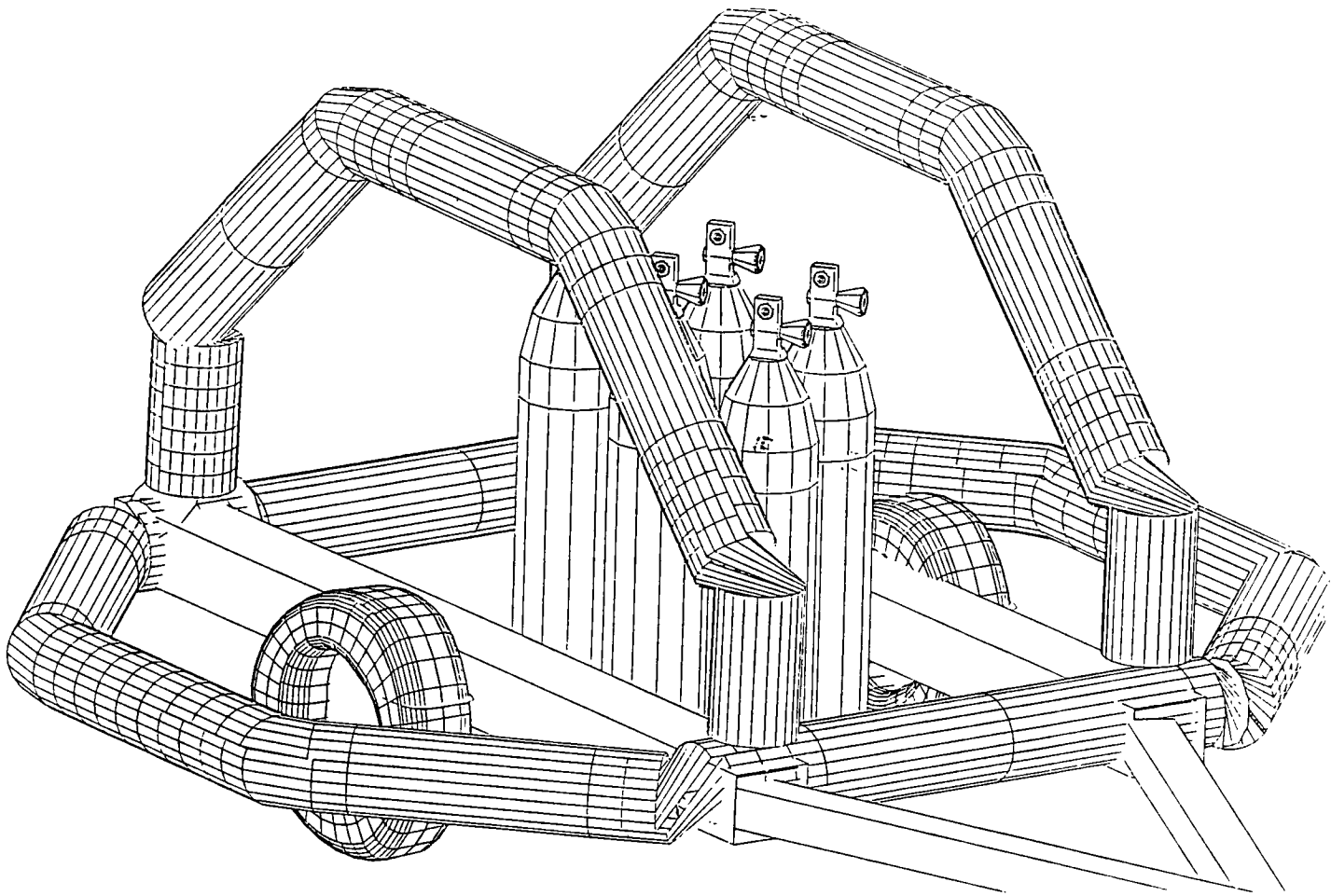

CAD sketch: hidden line perspective
- folding dock concept
- trailer base
- example of additional tanks in trailer

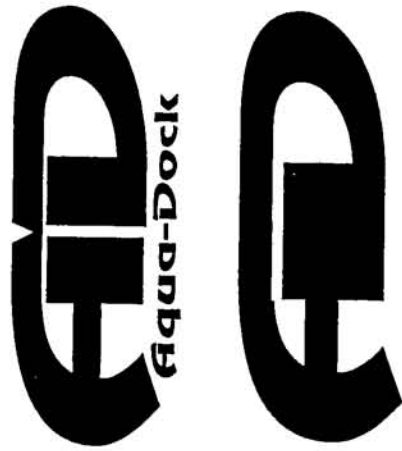

AQUA-DOCK

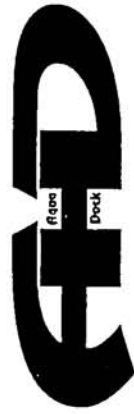
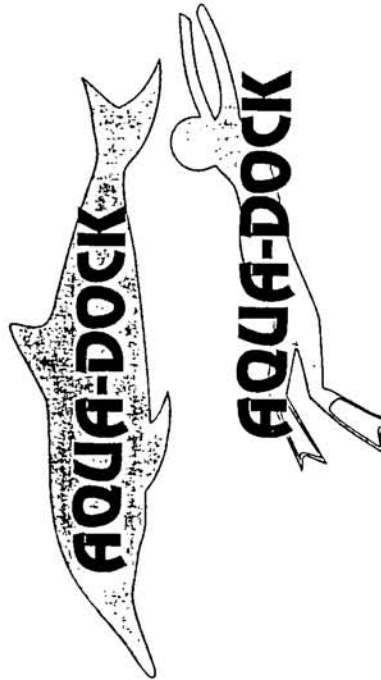

**AQUA
DOCK**

AQUA-DOCK Aqua-Dock
Aqua-Dock Aqua-Dock

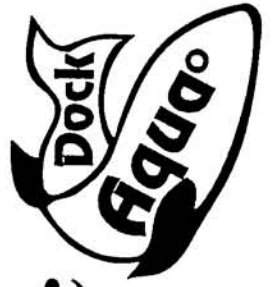

Aqua-Dock
Aqua-Dock
Aqua-Dock



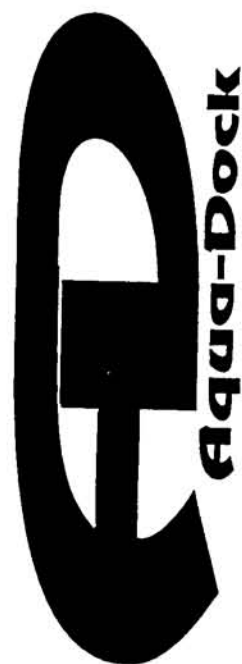
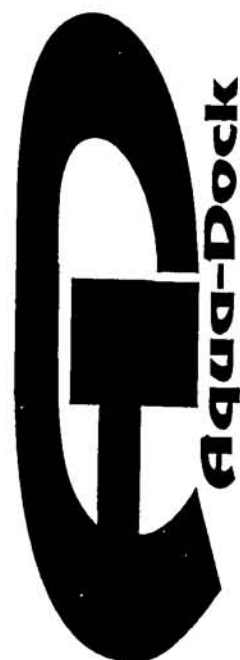
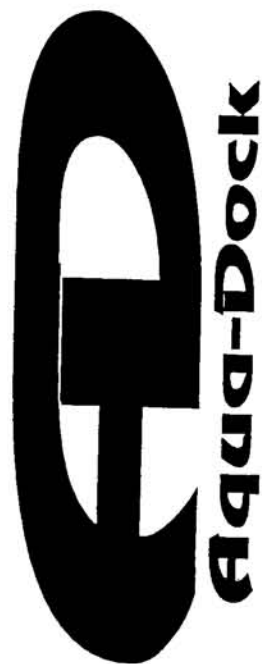
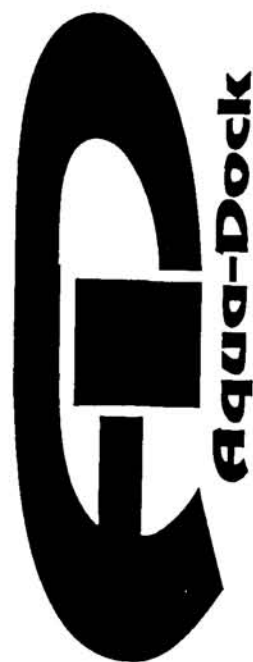
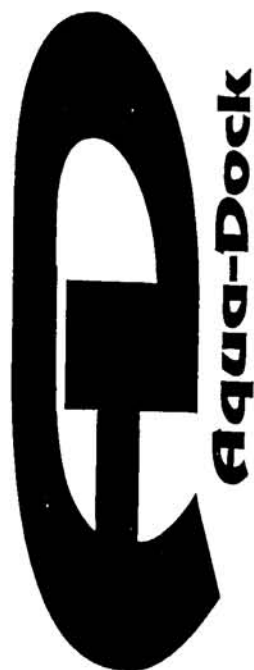
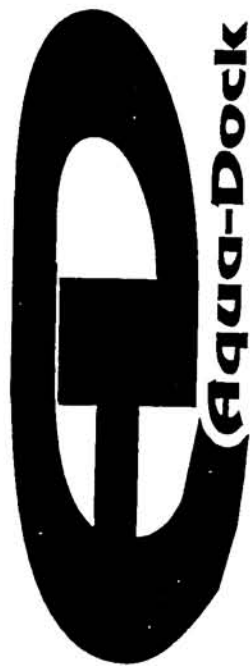

The Aqua-Dock is a portable, submergible dive platform.

The Aqua-Dock will aid instructors in the training of student divers in their basic skills

- It can be operated down to 60 feet
- Works in fresh and salt water
- Works off of one standard scuba tank (80 cu in, 3000 lb)
- One tank will allow for 6 dives at a depth of 30 feet
- Easy ergonomic design allows for minimal handling
- Can be broken down for easy storage and transport

Options include:

- gear bags
- night lights
- adjustable handles
- dive buoy

Price: \$2500.00
w/options \$3200.00



Aqua-Dock ®

An Aquanator product
Aquanator Inc. 555 Cherry Blossom Ln, San Demus, CA 60993 (516) 572-5587