

ROCHESTER INSTITUTE OF TECHNOLOGY

A Thesis Submitted to the Faculty of

The College of Fine and Applied Arts

In Candidacy for the Degree of

Master of Fine Arts

The Multiple Dimensions of Graphic Design

By

Jongruja Mai Viseshsin

April 29, 1992.

A P P R O V A L

Chief Advisor : Prof. Roger Remington

Date: 5/26/92

Associate Advisor : Dr. Richard D. Zakia

Date: 5/26/92

Associate Advisor : Prof. Nancy A. Ciolek

Date: 5-25-92

Special Assistant to the Dean for Graduate Affairs:

Prof. Philip Bornarth

Date: 5/27/92

Dean, College of Fine and Applied Arts:

Dr. Peter Giopolus

Date: 6/2/92

I Jongruja Mai Viseshsin _____, prefer to be contacted each time a request for production is made. I can be contacted at the following address: 335 Fairwood Circle, Rochester, NY14623

Date _____

ACKNOWLEDGEMENT

I wish to give special thanks to my thesis committee:

Professor Roger Remington --who always guided me towards a creative direction

Dr. Richard D. Zakia --who is very enthusiastic in giving me great and unexpected points-of-views

Professor Nancy A.Ciolek --for her encouragement which kept me working even when my thesis production was moving slow

And, I also give my sincere thanks to:

Mom, Dad, all my brothers and sisters --for their love and liberal support which made my graduate studies become a reality

Kukkai- for helping me to finish my final mechanical

All my classmates -especially Hyekyung, Michelle, Carla, and Michele -- for helpful and funny times all together.

C O N T E N T S

Introduction	1
Thesis Proposal	
The Reasons For Choosing a Topic	3
Important Ideas Formation	3
Selecting Thesis Advisors	5
Writing Thesis Proposal	6
Data Sheet	6
Thesis Procedure	7
Research	9
The Gestalt Perceptual Principles	9
Paper Constructions	12
Deciding How The Application Would Function	14
Design Process	17
A Modular Poster.....	18
Packaging Cover.....	21
Instructional Posters.....	22
Production	23
Conclusion	27

C O N T E N T S (C O N T I N U E D)

Appendix 1	Possible Graphic Design Theories_____	28
Appendix 2	Thesis Planning Report Requirements_____	29
Appendix 3	Time Implimentation Plan _____	30
Appendix 4	Closure Example _____	31
	Common Contour Example _____	31
	Similarity Example _____	32
	Continuity Example _____	33
	Proximity Example_____	33
Appendix 5	Guildline Flowchart'1 _____	34
Appendix 6	Paper Treatment Techniques _____	35
Appendix 7	Guildline Flowchart'2 _____	36
Appendix 8	Modular Cube Design _____	37
Appendix 9	Modular Cube Design _____	38
Appendix 10	Modular Poster Design _____	39
Appendix 11	Modular Design Instructions _____	40
Appendix 12	Packaging Cover Design_____	41
Appendix 13	Instructional Poster Design _____	42-43
Appendix 14	Packaging Cover Layouts _____	44-45
Appendix 15	Modular Poster layouts_____	46
Appendix 16	Final Visual Design Processes (Slides) _____	47
	Bibliography_____	48

INTRODUCTION

This thesis project is concerned with experiments in multiple-dimensional graphic design and has been addressed to a wide audience of graphic design professionals who are interested in working with paper shape and form. Its purpose is to explain how to apply two and three dimensional design to Gestalt perceptual principles. A combination between Gestalt perceptual principles and multiple-dimensional graphic design is revolutionary for how dimension can change within the Gestalt perceptual content.

Visual concept of Gestalt is a basic theory resulting from visual perception that represents the process of how the human eye and brain functions together. Gestalt theory usually relates to logical and practical applications in the visual arts and graphic design.

By introducing two-dimensional design functions to three-dimensional design functions, a transformation of optical dimension is created. These applications explain in detail how the principles of Gestalt relates this information to examples within the model.



To accomplish this optical dimension, the following elementary methods for simplifying, organizing and unifying images have been developed: closure, common contour, similarity, continuity and proximity. This completed thesis consists of a three-dimensional model, packaging design, and poster designs. My method of design experimentation will be explained in detail within the project description.

THESIS PROPOSAL

The Reason For Choosing This Topic

The most important reason for choosing to concentrate on three-dimensional design was because of my personal interest and valuable skills in industrial design from my undergraduate education. Knowing I would work on this thesis topic for long periods of time, I chose one that would be most enjoyable. Graphic Design work should not only deal with flat, two dimensional pieces; such as the poster and other printed matters, but with two-dimensional design also. This way it can represent perspective and isometric projections which convey three-dimensional design illusions.

Important Idea Formation

From the end of Spring Quarter, 1992, serious thoughts of formulating my ideas into a possible topic for my thesis project began. I presented two different variations on my ideas to my chief advisor, Professor Roger Remington. These topics were the Identity Design of The Thai-New York Golf Association or the Three Dimensional Graphic Design Concepts. A consultation with Prof. Roger Remington decided which topic would be the most effective to complement my industrial design background. Prof. Roger

Remington and I agreed that designing a three- dimensional piece and combining it with one theory of graphic design should be considered. This application could consist of posters, books, brochure, packaging, etc. At that time, no specific preference for my application had been indicated.

During the Summer Quarter, I dedicated my time to doing research about various graphic design theories which would combine with my three-dimensional application. I looked into theories of color, basic typography, design pragmatic, grid systems and perceptual codes. Meeting with Prof. Roger Remington again helped in discussing my possible theory ideas in detail. (See Appendix 1) From this meeting, Prof. Roger Remington and I decided that the perceptual codes would be the best foundation for my thesis work since perceptual codes represent the psychological processes of visual perception. Basically it explains how humans organize and group images together. Not only do they relate to two-dimensional vision, but they also relate to three-dimensional vision. With this definition, perceptual codes were utilized as my focus of thesis concentration.

Selecting Thesis Advisers

Before handing in my thesis proposal, I selected my thesis advisors. The position of chief advisor was filled by Prof. Roger Remington, main professor of the graduate graphic design program. But due to the requirements within the College of Fine and Applied Art, two more thesis committee members were needed. I consulted with Prof. Roger Remington about who would possess knowledge of perceptual theory. Prof. Roger Remington suggested to ask Dr. Richard D. Zakia, Professor of Photography, to be an associate advisor. I introduced myself to him and explained my thesis theme. Dr. Zakia showed an interest in my project and agreed to help. Having him on my thesis committee was very helpful in leading me towards a creative, successful project.

Prof. Nancy Ciolek, Assistant Professor of Graphic Design was selected to be my third associate advisor. She always gave me different viewpoints and comments which kept me inspired throughout my production.

Writing Thesis Proposal

After deciding my thesis topic, I wrote a broad thesis proposal statement which would cover the overall scope of my thesis. The finished proposal read:

"The purpose of this thesis is to investigate perceptual code theory by using multiple graphic media which combines two and three- dimensional design. My application will consist of poster design and an assortment of two and three dimensional design."

Data Sheet

At the beginning of Fall Quarter, 1992, I began working on a thesis time planning report which was reviewed by Prof. Roger Remington once a week. (See Appendix 2)

By following this planning report, a clear vision of where to focus my initial thesis ideas and from which direction to begin working was determined.

Thesis Procedures

By the end of Fall Quarter, a list of goals and objectives for my thesis was achieved. This description would explain the benefits of my finished project. This important list lead me to analyze my own ideas and problem solving methods.

The approach towards my goals was summarized as follows:

Design Goals

1. Associate different characteristics between two and three dimensional environments
2. Base it on a proportional grid system
3. Design in a versatile, interesting, and visually exciting style
4. Focus context on informing the audience about design theory

Design Objectives

1. Support the graphic design curriculum
2. Show special, creative possibilities of paper's function
3. Invent paper construction in various three dimensional forms
4. Emphasize the manual aspect of working with paper



purposes

6. Show appropriate information (content)

7. Discover the transformation potential of specific forms

8. Encourage experiments in geometric shapes and their results from extended structures

Timelines

Formulated timelines (See Appendix 3) indicated the dates and work procedures for completion of the project. The timelines helped me make sure I would finish major deadlines for the thesis application.

RESEARCH

With my topic of perceptual objects and goals for my thesis proposal, my second step was to research how Gestalt theory involves visual design, composition, and its categories. At the same time, I started to research the characteristics of paper. Since I was dealing with three dimensional pieces, I needed to know about paper materials, techniques, texture, and how to apply the best qualifications for my project. As a result of this, I divided my research into two separate parts:

The Gestalt Perceptual Principles

After completing my research in The Wallace Library of Rochester Institute of Technology, I read many books about Gestalt theory. These books were highly detailed in concept. During this time, I felt frustrated since many of the books have a deep concern with psychology. It was difficult identifying the Gestalt principles into specific psychological categories. So I thought about locating definite Gestalt theory books that focused on artistic directions. I asked for another book list from Dr. Zakia, an expert in design theory. He gave me a list of several books which were very helpful in my research development. Some of these books



involved specific graphic design works and even photography. I summarized and gathered sample imagery (See Appendix 4) which revealed parts of the Gestalt theory as follows:

Visual concept of Gestalt is a resulting theory of visual perception within one field of psychology. The Gestalt perceptual theory is directly related to artists. It helps an artist unify their work to produce harmony and fascination within the piece. If the artist understands and uses this visual process, he or she will be able to lead the viewer to see whatever they need to communicate an idea through their work. The Gestalt Perceptual theory's concern is how the eye and brain continuously takes the viewer through an organizing, simplifying, and unifying process of the entire image before the eye moves on to details and perceives them as the sum of the parts. The viewer will search for relationships within each detail and group them together. This perception depends on the position of the units which can be divided into the following categories:



Figure and Ground : The first step to perception application is noticing figure from ground.

The figure usually appears to be on top or in front of the ground, even though the figure and ground are in the same physical plane.

Closure: Closure is one method of visual grouping which is based on the human ability to close an incomplete shape, form, pattern, or organization of images.

Common Contour: The visual process of grouping two or more objects together to share the same edge, causing a competition among the others.

Similarity: Visual elements which have similar characteristics of shape, size, position, organization, color, and value will most likely become a group.

Continuity: Continuity occurs when the viewer's eye is carried smoothly from one unit to the next.





Proximity: Objects that are near one another have a tendency to be grouped. They appear visually together but with a small gap between them. Groups may include a variety of shapes, sizes, and positions.

Paper Constructions

During my research of Gestalt theory, I also reviewed paper construction. To formulate ideas for my thesis project, it was necessary to understand the various possibilities paper may have as a plastic material. The very nature of paper and its surprising capabilities has brought it into intimate contact with two different dimensions, which I intended to utilize my perceptual theory application. I decided to explore the material of paper where a fusion of my creative artistic ideas and functional techniques could elevate into a new dimension.

Flat Surface Treatments: If we draw a circle and cut, fold, and bend a semicircle into its surface, at regular intervals, we can create some interesting and beautiful light and



shade effects. This type of surface design is particularly effective when used for backgrounds of exhibition cases, show windows, or to decorate large wall areas. Cutting and pushing in or pulling out the extracted areas is a great value for surface decoration, especially when making representations of different dimensions.

Spatial Dimension Constructions: With simple clean processes, we can cut or bend a piece of paper into a three-dimensional form which has its own type of aesthetic order. When we make dimensional constructions by cutting, folding, bending, or joining paper, we are making paper sculpture that possesses our own ideas and thoughts of how we express ourselves creatively. Through high and low reliefs, the flowing movement of soft, curved surfaces, the contrast of strong and weak lines, and the harmonious rhythm of light and dark values, we can give form and reality to ideas and open the doors of pure creativity.

Deciding How The Application Would Function

After finishing my research, I thought of unifying all this information. I tentatively decided to establish the first flowchart (See Appendix 5) which was presented at the first meeting with my thesis committee. This chart showed a series of posters which were divided into five sections. The purpose of each section would describe a different principle of Gestalt theory while merging with different dimensional functions at the same time. The first division began with a flat poster design. The value of dimension increased until the series completed in the fifth division and become an entity of three dimensional form.

Besides making this flowchart, I continued to work on the paper construction elements based on my previous research. Several poster examples with different dimensional functions were made. I wanted to make sure that my committee understood how my poster would transpire. To achieve this communication, a three dimensionality by using a flat sheet of poster paper. Circular images were made to represent the principle of Gestalt theory and to experiment with different paper treatment techniques. (See Appendix 6)



After finishing my flowchart and poster examples, I arranged my first thesis committee meeting for January 15, 1992. A major point of discussion was which principle of Gestalt theory would be appropriate for each poster. The thesis committee indicated one principle of Gestalt, Figure and Ground, which was divided into one of five categories. Figure and Ground was placed as the first principle in the first panel while the remaining Gestalt theories were divided into the other five categories. The thesis committee had the same idea for using this topic as the main function but which would go along with all the categories and represent more than just its dividing part. They agreed on placing Common Contours in at least one panel. For matching the Gestalt principles with different dimensional functions, the committee said they would not be able to decide until they could view some design sketches for each poster. Beginning with any of the five posters, I merely matched them with a Gestalt principle that was most appropriate. This helped me find the best resolution for each design.



During this meeting, we also talked about the audience scope, whether it should be geared towards general designers, graphic designers, or exactly which audience level I should approach. We decided to choose the graphic design audience since my thesis topic may be too broad for the general designer to understand and being a graphic designer, I would utilize not only the Gestalt theory, but also the basic functions of graphic design and how it relates to graphic design audiences. My thesis would describe how the graphic designer could apply Gestalt theory into their own work.

DESIGN PROCESS

To design a series of posters based on my revised flowchart, (See Appendix 7) I decided to work on the design backwards, from the last three-dimensional panel which would be the most difficult and challenging to the intricate theory within the application. Beginning with the cube as a departure point for this series of experiments. Not only because it was a simple figure, but because its geometric shape contained regular structures which are quite unique in body stiffness. Following the five principles of Gestalt theory, modification to the basic cube into five different forms of geometric treatment evolved. (See Appendix 8) After several attempts, the five best resolutions for the cubes were selected. (See Appendix 9)

When satisfied with the cubes, work began on the fourth division which was the pop-up poster. Designing the pop-up combined geometric form with the characteristics of each Gestalt principle and soon became rather intricate. All pop-ups must be made very carefully, or they will collapse when flattened. The completed level of deep gradation transformed from the two-dimensional to three-dimensional level within the second design step.

The third design step held a significant discovery which eventually lead me to the finished thesis work.(See Appendix 10)

A Modular Poster

An integration of five main ideas for the posters were combined into one model which was called "The Modular Poster". This idea was presented at the second thesis committee meeting. Its functions can be described as follows:(See Appendix 11)

- The Modular Poster was formed into a square cube shape that could be opened in a diagonal direction.
- The Modular Poster was installed with a flat folding panel. The folding panel pieces were constructed to the end flap and to an inside sheet of the cube model which opens and closes to reveal or enclose the second division.
- The folding panel was divided into four divisions. Each division was constructed with two partitions. One side represented images and the name of the principle. The opposite side represented the principle's content.
- The proportion of the modular cube became the basic unit for the constructional grid layout and was used to place the visual elements in order to create unity throughout the whole



poster. The constructional grid "Identifies the elements, studies their inherent proportional relationships, and builds compositions from their interlocking parts." (Remington)

The final design for the modular cube consisted of five divisions represented in the following list:

I. Closure:

In the first division, a perforated circle was implied surrounded by a one-third inch circle. An incompleting circle would be seen visually complete because of the perforated circle inside.

II. Common Contour:

Common Contour was the basis for this panel. Two circles shared the same edge, both belonging to one another, even though they were cut and folded with one side back, which exposed the part with the penetrated holes. My attention concentrated on the relationship between the protruding and receding planes and the relationships between the negative and positive areas.



III. Similarity:

Three circles on the middle left side had similar size and color relationships which were strongly defined as a group. Cutting and folding the parts of these similar circle intervals, broke up a large area and produced an interesting effect of gradation.

IV. Continuity:

The continuity principle was perceived as the transition between the cube of the proceeding panel and the folding planes. The subtlety of the pop-up techniques added a necessary dimension to the four circles, which further enhanced and complemented the simplicity of the entire image. There was continuous motion from one image to the next. The circular elements were similar in shape and progressive in interval orientation, but the level of folding directions were different causing a united movement.

V. Proximity:

Proximity was visually represented three dimensionally by grouping different layers of the major five circles. The five layers were folded in different directions which became spherical when standing up by itself in one corner.

Packaging Cover

The packaging cover idea evolved when I decided to make a modular poster. The modular poster would be kept safely inside this package. It would open with a dynamic function that would easily complement the model inside. The graphic elements on the package would also describe Gestalt theory, because of the concentration on Gestalt theory within the modular poster. The circular shape was accented again as the dominant point.

After several attempts, (See Appendix 12) the most effective design was selected. The solution consisted of a huge "G" image from the Gestalt title which branched out into five smaller circles to indicate each name of the principles. These images occupied three sides of the box. The title "Gestalt Perceptual Principles" was dropped in on the middle, right-hand side of the front panel. The Gestalt content was aligned to the right side of the back panel. A warm, red color was used to highlight the important words such as the title, the five names of principles, and the Gestalt quotes. (See Appendix 16)

Instructional Posters

This was a set of two posters describing how Gestalt theory was applied to my thesis project. (See Appendix 14) The first poster illustrated the meaning of Gestalt theory. The second poster consisted of the flowchart which was used as the guideline for my design process. The basic concern of the first poster would relate visually to the manipulated format of the packaging cover previously described. The images on the packaging cover had been divided into an isometric view. I needed to transform them into a two dimensional poster. An embossing technique was utilized for the circular images which referred back to the three dimensional package piece. The red bars were added later, across the top and the bottom of both posters, causing a coherent unification throughout the whole poster design and emphasizing the contents between them. (See Appendix 16)

PRODUCTION

My initial concern with the production process was producing a small, sharp display of copy and fine lines. Since the deadline for thesis application approached rapidly, I did not want to deal with any extra time consuming production processes. A mixed media process was chosen to produce my final design. I felt comfortable using mixed media since I have always used it with my other projects. The resolution of Chromatec was rather accurate in size and color. Another option was INT, which has less color choices, a fixed quality, and are less expensive than Chromatec. For the final applied modular poster design, packaging cover, and instructional posters, I decided to utilize gray, black, and warm red for the color palette. Gray had been used as the background paper color. The mechanical began with categorized red elements from which black elements eventually evolved to produce film negatives. The film negative of red images were produced into Chromatec. It took approximately a week to complete. For the black images, an INT was used, which would be produced faster the Media Center in the Graphic Design Department of RIT.

While waiting for the Chromatec and INT processes to be completed, I began working on the paper construction models which were needed before finishing the presstype. This meant that I could burnish down all the type and graphic elements and complete my thesis application. There is an excessive amount of paper types and qualities available for specific purposes. Many quality papers are identified by their various weights. It was important to decide which weight of paper would be appropriate for each model.

The packaging cover model was built from gray cardboard of a 400 gsm. weight which supports tough construction. This model was made from a simple layout. (See Appendix 14) The key to making this packaging cover model was knowing how to form a strong net with accurate measurements, so that the model would lock together securely.

The modular poster was made from the same hue of gray cardboard but with 200 gsm. weight. Because of the limited size of cardboard, I separated the model into two sections. The cube model and the folding panel pieces became the



new existing layout. (See Appendix 15)

The circular images on each panel had to be cut very carefully with a professional circle scalpel before creasing and folding the parts of these circles to the following design layout.

The instructional posters were made from a 180 gsm. weight of bond paper. A relief image was achieved by embossing the paper. The cardboard shape was cut out from the design and placed under the paper in the required position. This embossing technique was achieved by burnishing the front with a burnishing tool. This technique would raise the images to the surface on the front of the sheet.

Once the constructional model was complete, I purchased my INT from the Media Center and Chromatec from a production studio. The final project was almost complete, but then I found a few problems. One major problem was that the chromatec would not stick to any of the paper after I burnished it down, especially the small details. I decided to take the defected chromatec back to the production studio



for replacement. Fortunately, it only took one day to reproduce. The other problem was the black INT. One day after purchasing, it was discovered that the processing machine had not worked properly. The size of my layout had changed, therefore, causing the Media Center to redo the sizing and another INT. That following afternoon, a perfect black INT was produced and I returned to finish the mechanical. The images were applied with no problem and soon they were all in position. This brought a completion to my thesis application. (See Appendix 16)

C O N C L U S I O N

Overall, I felt this thesis project was a technical, yet practical application to apply, which utilized my knowledge of graphic design from the past two years. It taught me how to manipulate several concepts and ideas which required a great deal of sensitivity to organizing practical processes within design problem solving. Through the Multiple Dimension of Graphic Design, I was able to unify two different dimensional designs with the Gestalt Perceptual Principles into my entire project. As a result, this thesis project was successful in accomplishing my initial goal of design.

APPENDIX 1

Possible Graphic Design Theories:

1. Graphic Design Process
2. Theory of Color
 - Principle of color design (Include color combination)
3. Perceptual Code
4. Contemporary Graphic Design
5. History of Bauhaus
6. Basic Typography
7. Computer Generated Design
8. Self-Promotion (Designer Portfolio)
9. Paper for printing processes
10. The Grid System
11. Problems and solutions
 - Visual Thinking for Graphic Communication

APPENDIX 2

Graduate Graphic Design

(Remington)

Fall Quarter, 1991

Thesis planning report requirements:

1. Proposal draft(s)
2. Select thesis committee
3. Data sheet draft(s)
4. Full thesis proposal draft(s) (Plummer)
5. Communication analysis form (Lasswell)
6. Marketing questionnaire (Remington)
7. Semiotics analysis form (Zakia/Remington)
8. Interpretent matrix (Ockerse/Nadin)
9. Analysis, review and reversions
10. Final report

APPENDIX 3

Time Implimentation Plan:

1991	Date	
September	5	Begin a Thesis Proposal goal and begin a Project Proposal Plan (class)
	27	Finished Thesis Proposal due to Prof. Phil Bonarth, Special Assistance Dean of Graduate Student
October	3	First proposal draft due to Prof. Remington -Found the subject that related to the topic statement
	4	Went to paper shop to get the paper sample
	10	Second proposal draft
November	12	Final Project Proposal Plan due to Prof. Remington
	13	End of Fall quarter
	28	Thanksgiving Day
December	3	Beginning of winter quarter/ Official thesis work begin
	21	Last day of class before Christmas
	25	Christmas Day
1992		
January	1	New Year's Day
	6	Class resume
Febuary	24	End of Winter quarter
March	8	Beginning of Spring quarter
	9	First Thesis Exhibition
	30	Second Thesis Exhibition
April	20	Third Thesis Exhibition
May	15	End of Spring quarter
	23	Commencement
June	12	Finish Thesis book due to Dr. Joanne Szabla

APPENDIX 4

Closure Example



Body Language: Note that both the V in Alvin and the A in Ailey are formed from the body of a single dancer, with the leotard both defining the torso and separating the two letters.

Common Contour Example

Womb with a View: The late Herb Lubalin's award-winning logo graphically transforms three simple words into a striking image.

MOTHER
CHILD



Similarity Example



Gilbey's. The Authentic Gin.

Continuity

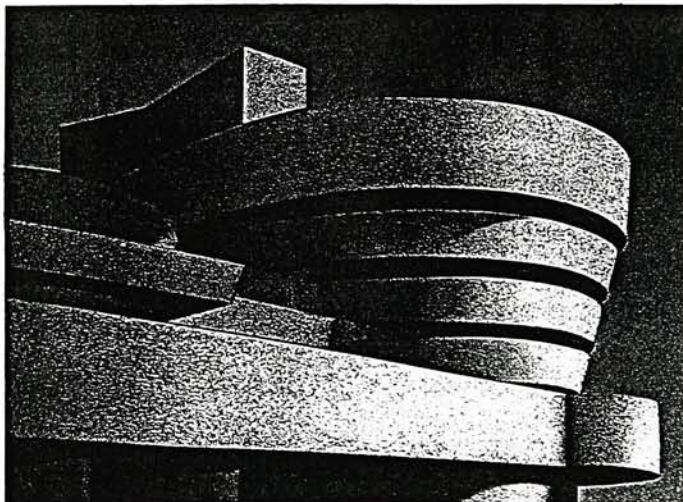

Proximity Example

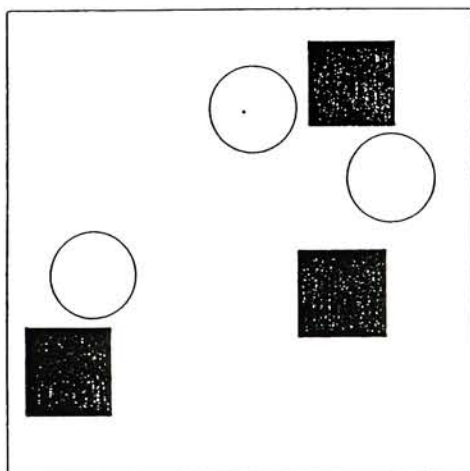
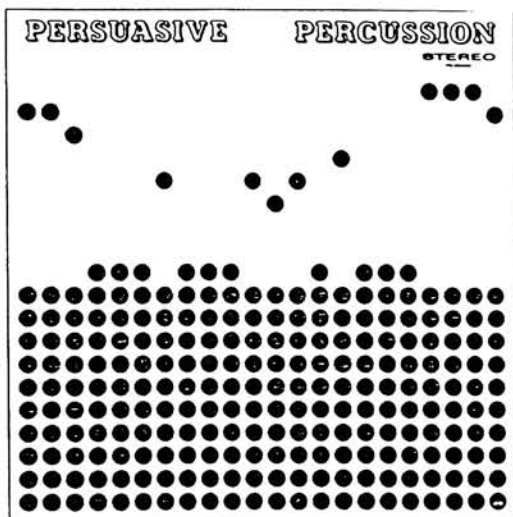

APPENDIX 5



Topic: The Multiple Dimensions of Graphic Design

Theory: Perceptual Code

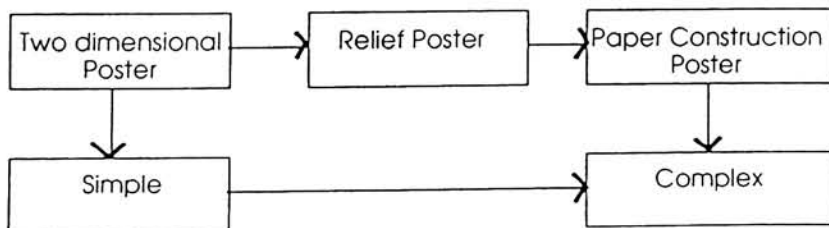
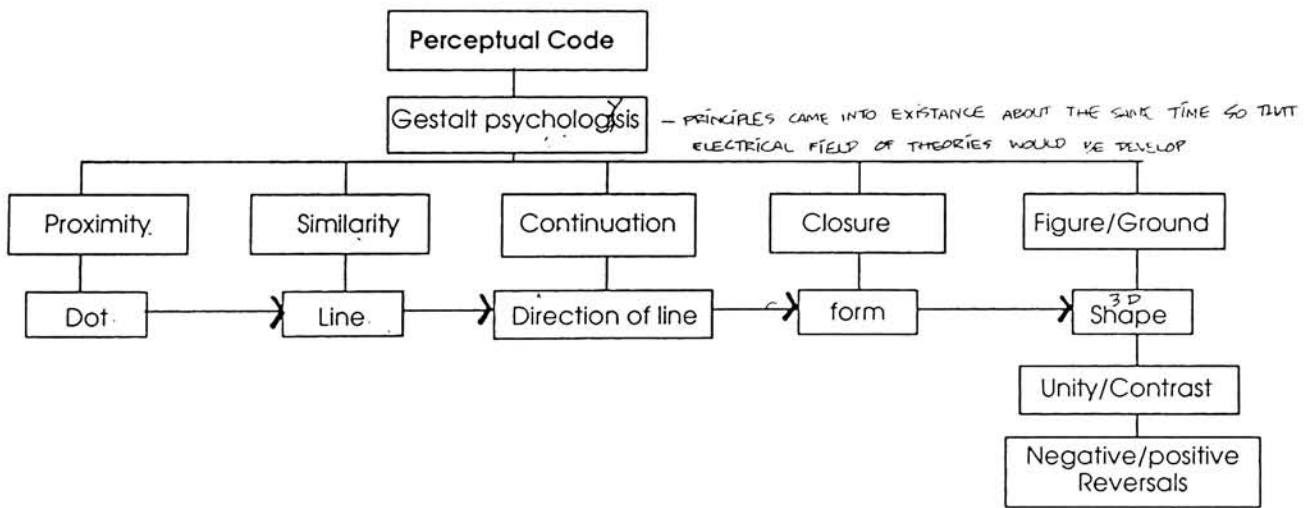

APPENDIX 6

Paper Treatment Techniques

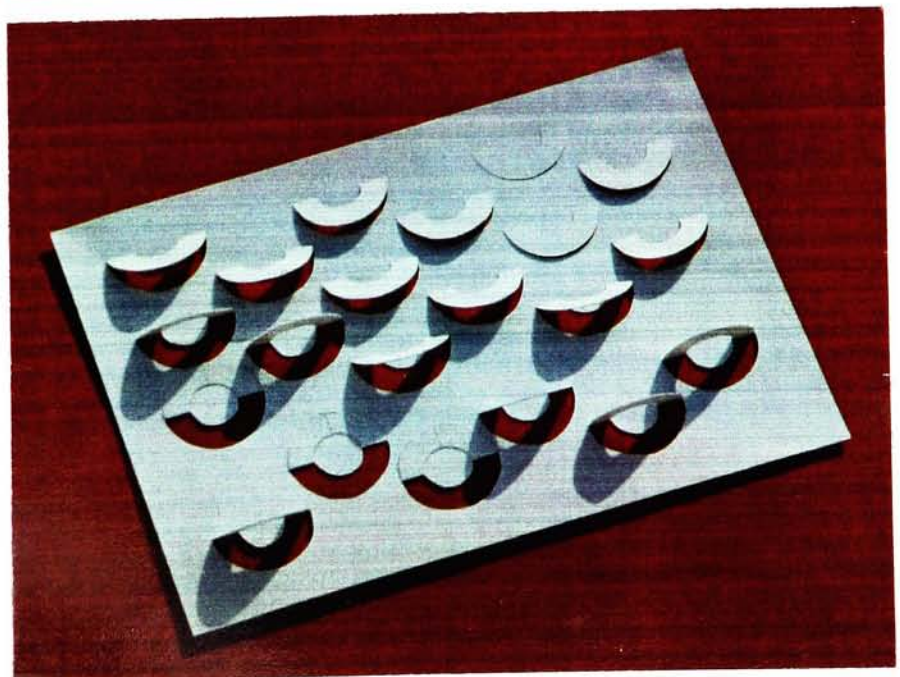
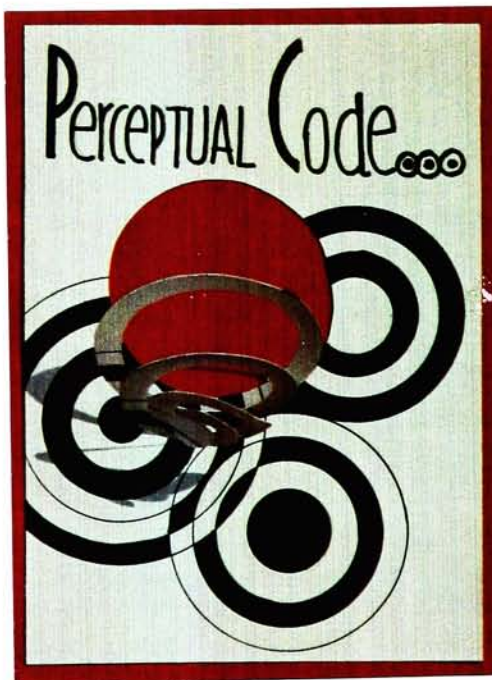

APPENDIX 7

Guideline Flowchart

	Dimensional Function	Gestalt Number	Texture	Tonality	Graphic Element	Typographic Application	Color	Gestalt Perceptual
Series 1	2 Dimensional flat form	#1	Simple	Dark	Contrast	Dot	Contrast	Figure/Ground
Series 2	IMPLIED DIMENSION	#2						Closure
Series 3	Relief form	#3						Continuity
Series 4	POP-UP	#4						Similarity
Series 5	3 Dimensional form	#5	Complex	Light	Unity	Cut out Shape	Harmony	Proximity

The Priority Process: The relative importance of factors from

1. Graphic Image
 - Number (follow the order of posters)
 - Simple shape (square, circle, triangle)
2. Typographic Application
 - (depend upon the content of each posters)
3. Color
 - (use of coherent color through all series of posters)

Other Considerations: -Overall the Multiple Dimensions Theme

- Graphic Image Relationship
- Type Relationship (Heading to Text)
- Organization Format (Use of Grid)

Post

COM-
CONTOUR

- (1) SKETCH VALIMTE
- (2) EVAL ?

APPENDIX 8

Modular Cube Design

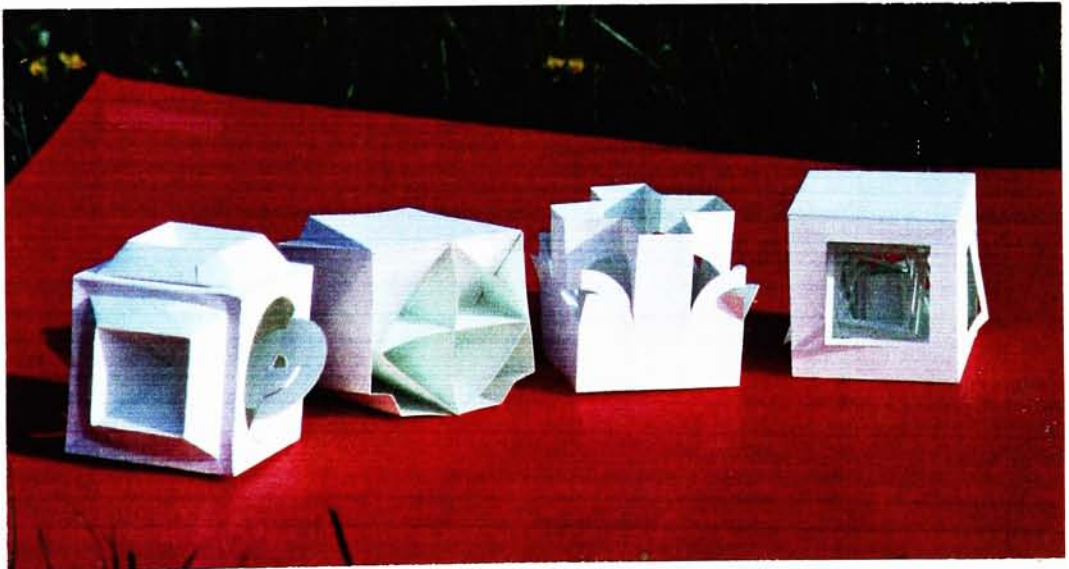

Modular Cube Design

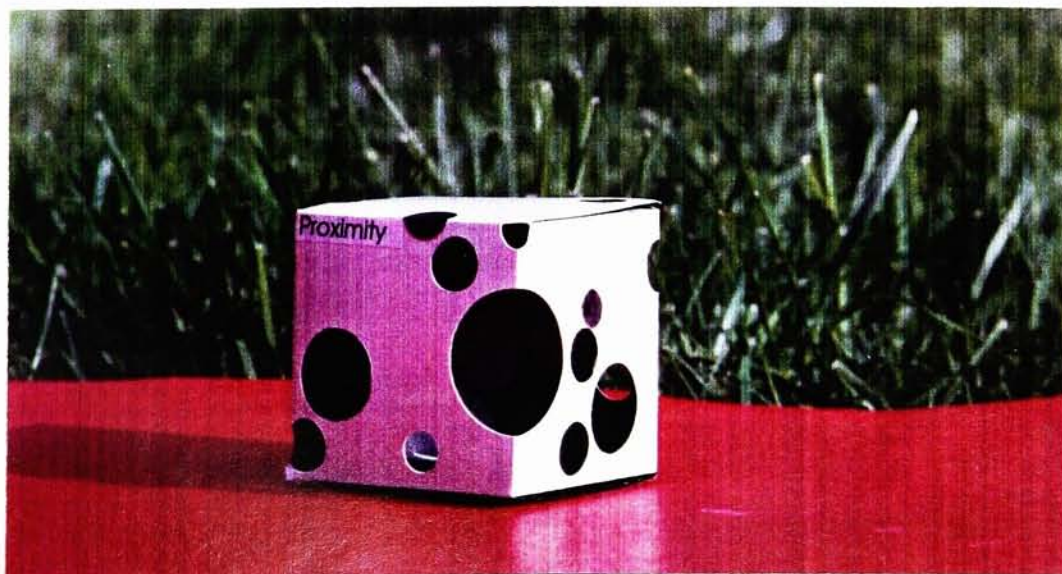
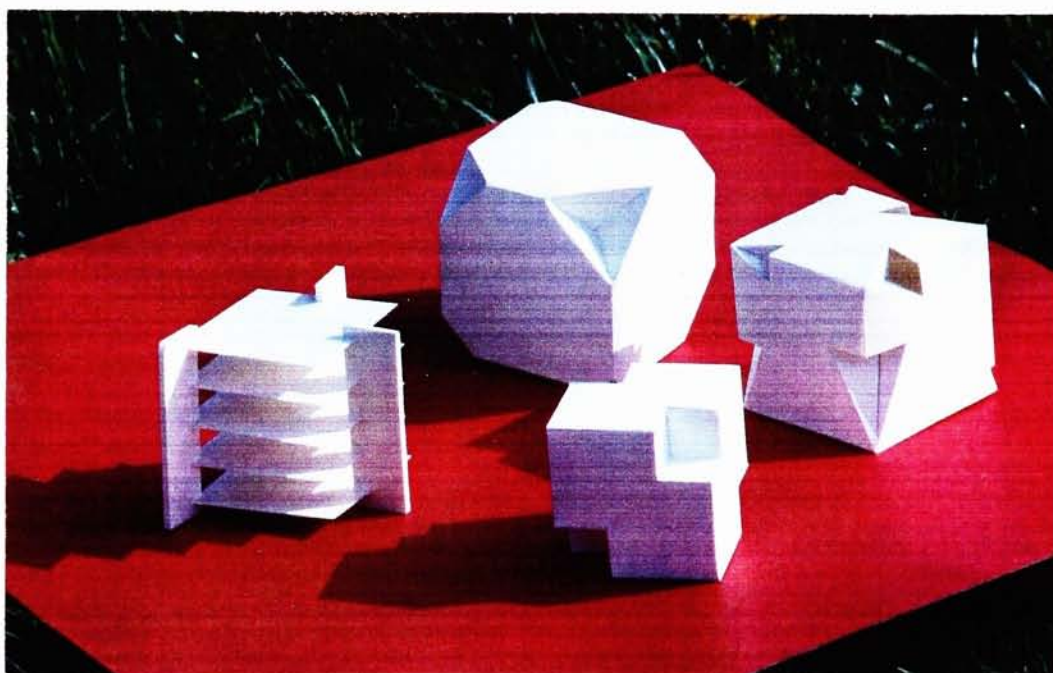

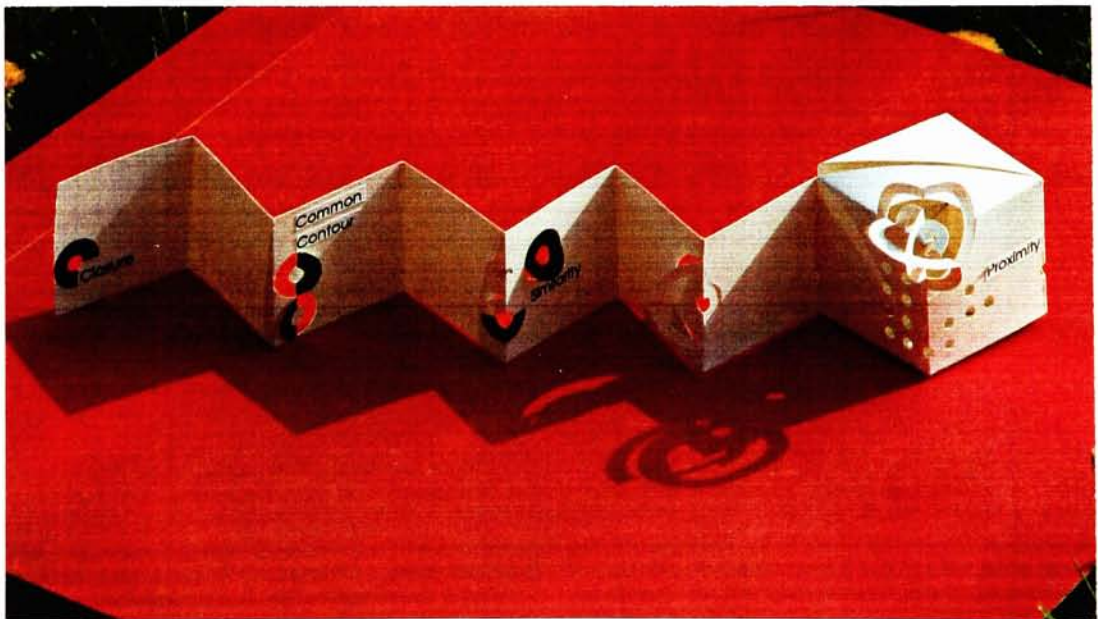
APPENDIX 10**Modular Poster Design**

APPENDIX 11

Modular Design Instructions

1.

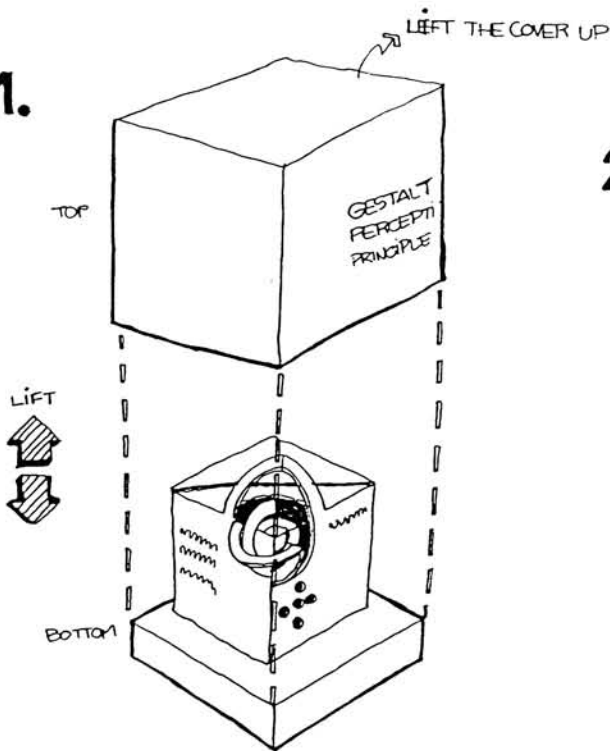

2. OPEN DIVISION INSIDE

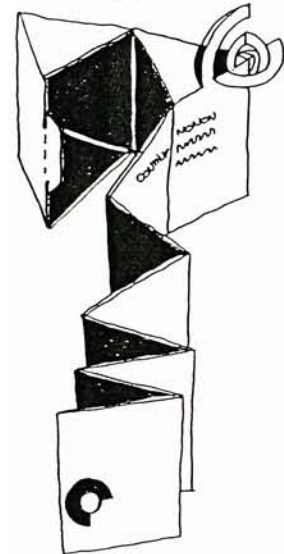

3.

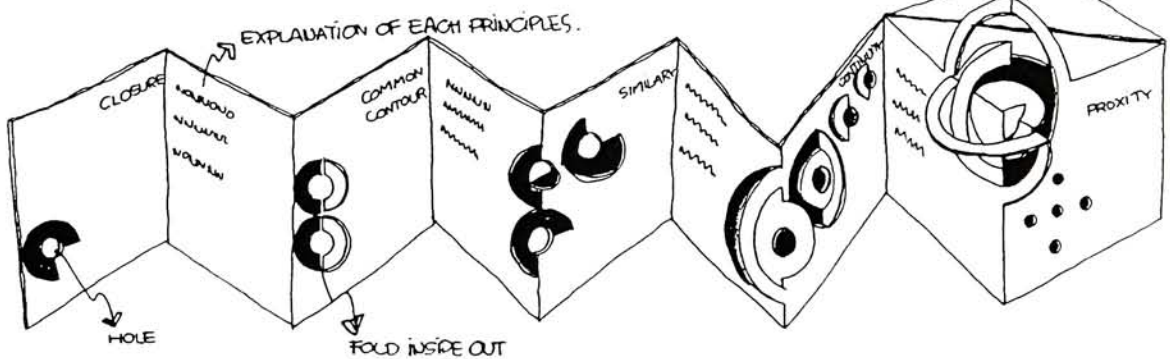

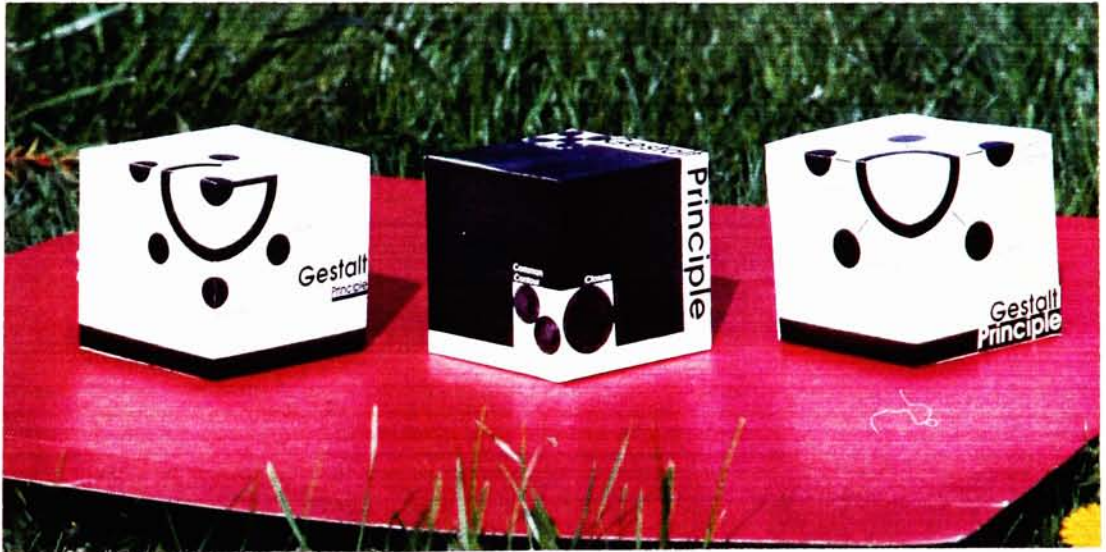
APPENDIX 12**Packaging Cover Design**

APPENDIX 13

Instructional Poster Design

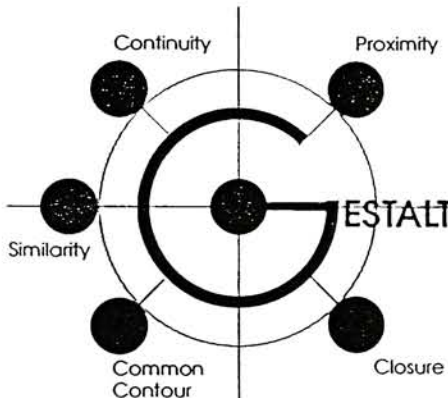

GESTALT PERCEPTUAL PRINCIPLES

The word Gestalt comes from the German and has the approximate meaning of shape from configuration, pattern. In terms of design it means that the "whole is different from the sum of its parts." A picture made up from a mosaic of tiles the picture has shape, from pattern, meaning.

Rasheed bin Fouad

● ● ● ●
 ● ● ● ●
 ● ● ● ●
 ● ● ● ●

Through a unique application of the Gestalt principle, this special prototype of multiple dimensional graphic design conveys visual awareness to a wider audience of graphic design audience. Gestalt principles are a basic theory that based on psychological and perceptual values.

Gestalt theory relates to logical and practical applications in visual design. The basic principle is, "Images are first perceived as unified wholes before we see the part that make up the whole."

To accomplish this, the following elementary methods for simplifying, organizing and unifying images have been utilized: closure, common contour, similarity, continuity

Instructional Poster Design

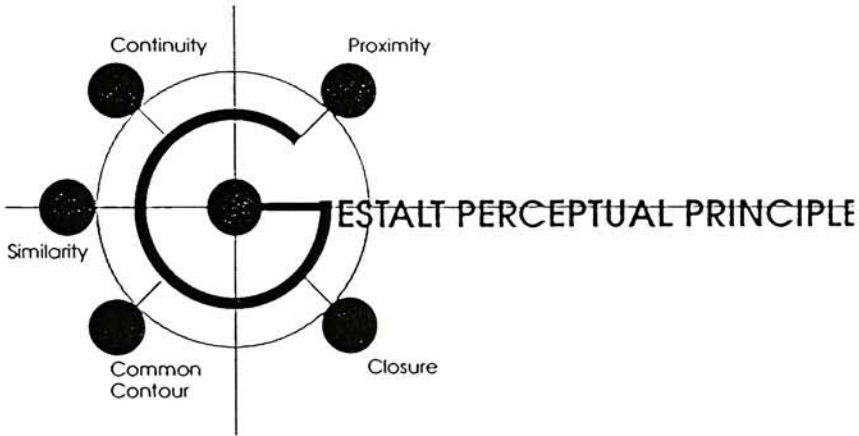

GESTALT PERCEPTUAL PRINCIPLE

Through a unique application of the Gestalt principle, this special prototype of multiple dimensional graphic design conveys visual awareness to a wider audience of graphic design audience. Gestalt principles are a basic theory that based on psychological and perceptual values.

Gestalt theory relates to logical and practical applications in visual design. The basic principle is "Images are first perceived as unified wholes before we see the part that make up the whole."

To accomplish this, the following elementary methods for simplifying, organizing and unifying images have been utilized: closure, common contour, similarity, continuity and proximity.

The word Gestalt comes from the German and has the approximate meaning of shape, from configuration, pattern. In terms of design it means that the "whole is different from the sum of its parts." A picture made up from a mosaic of tiles that make up the picture -the whole. The picture has shape, from pattern, meaning.

Rasheed bin Fouad

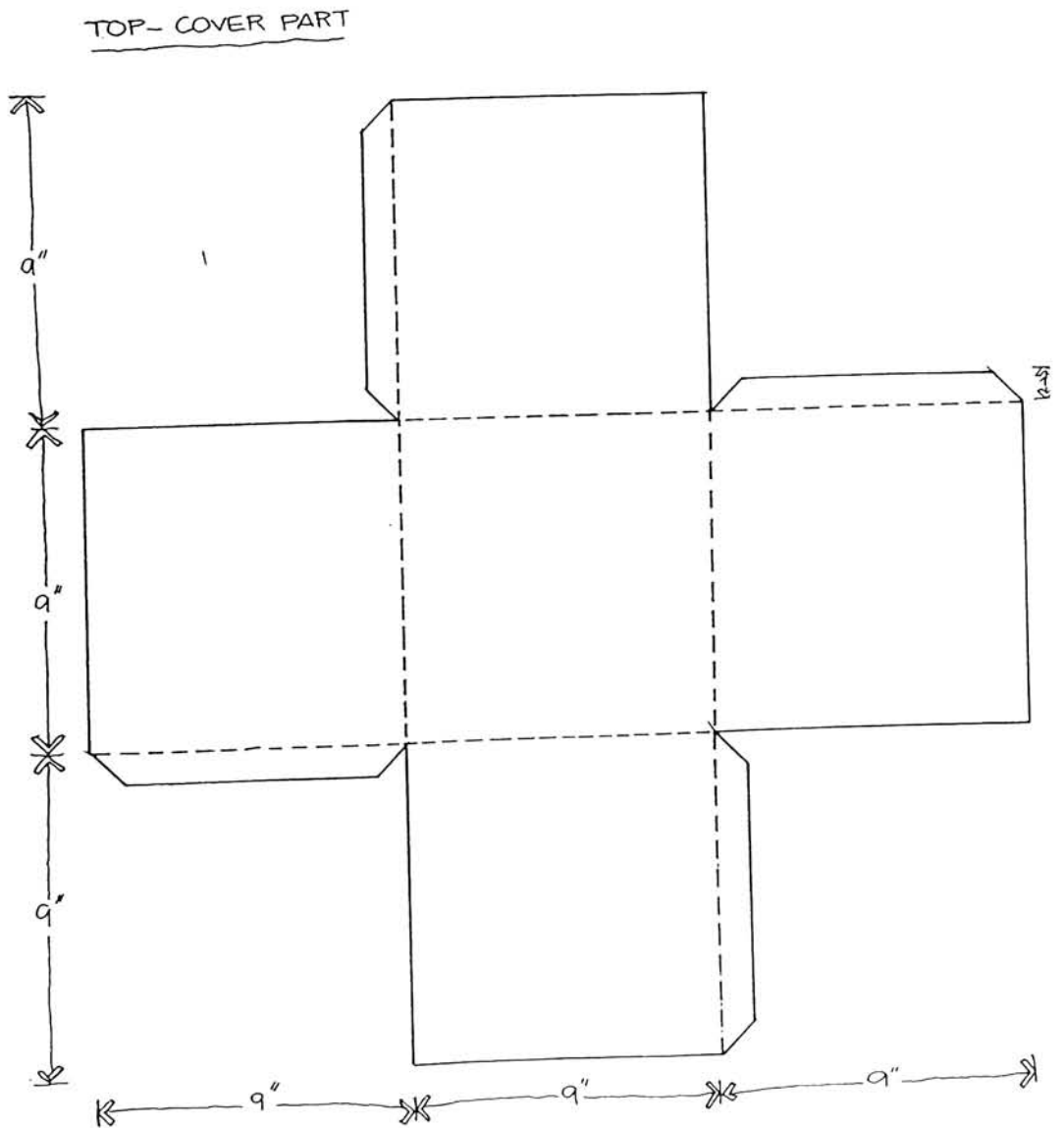
APPENDIX 14**Packaging Cover Layouts**

Packaging Cover Layouts

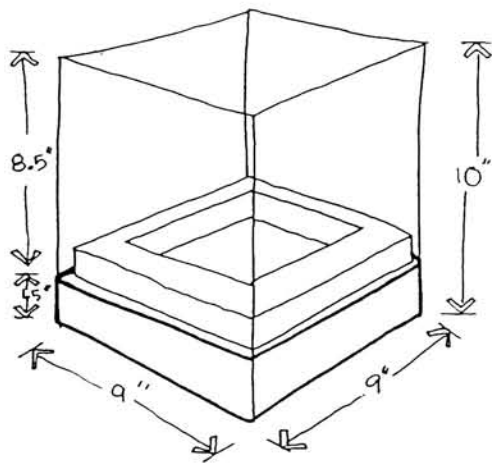

PERSPECTIVE VIEW

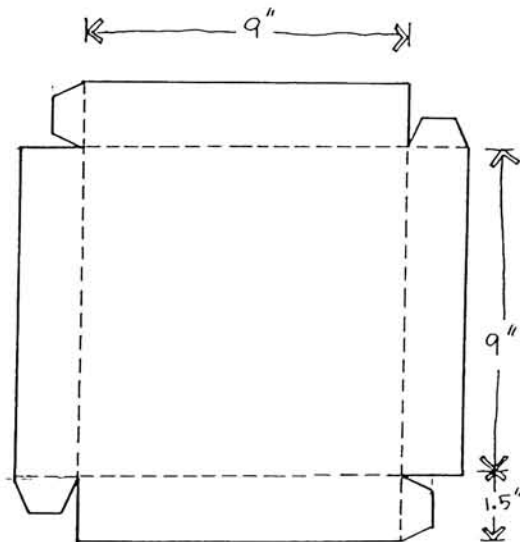
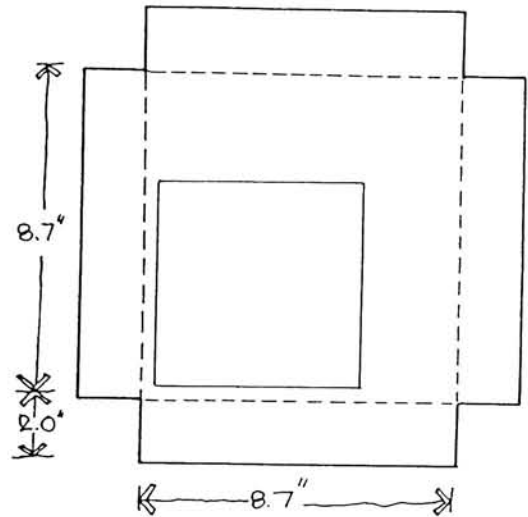

APPENDIX 15

Modular Poster Layouts

MODULAB CUBE

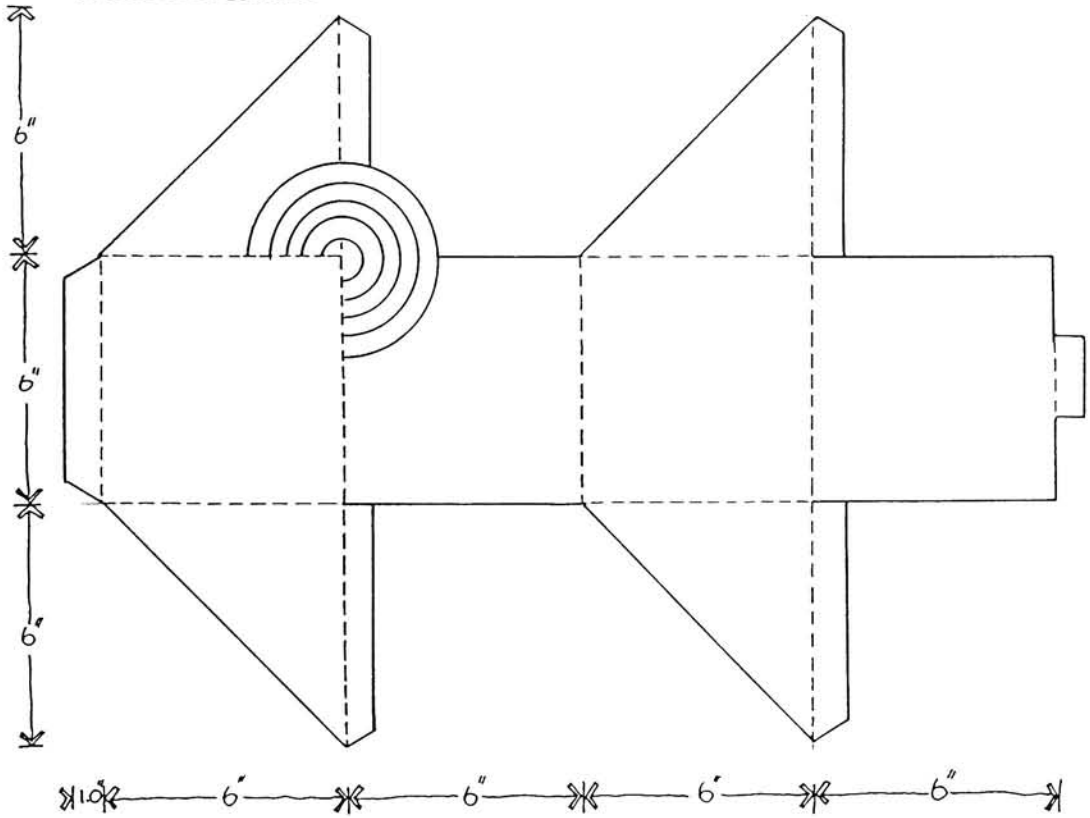

4 DIVISIONS.

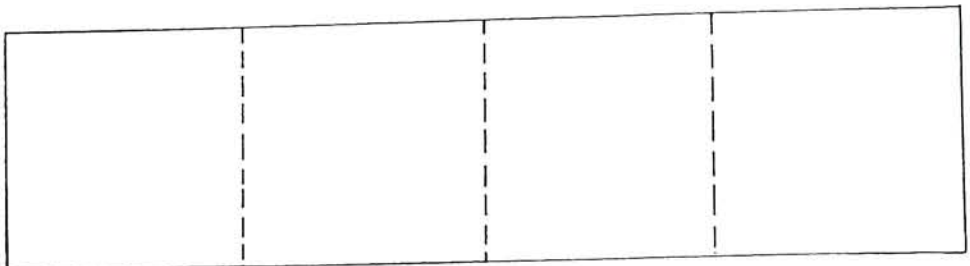
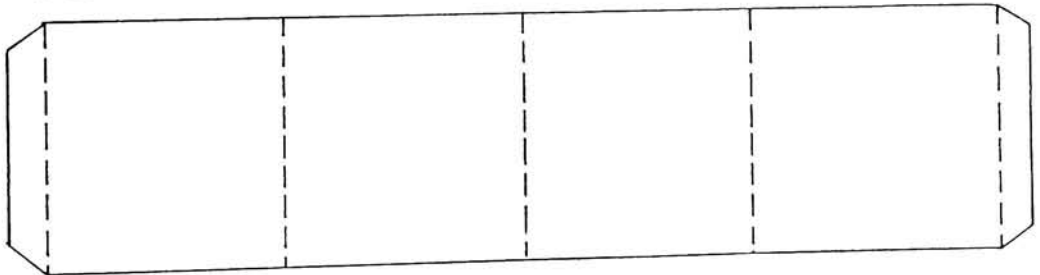

APPENDIX 16

Final Visual Design Processes

- Modular Poster
- Packaging Cover
- Instructional Posters



APR 82F03

17

APR 82F03

19

APR 82F03

31

28

APR 82F03

21

20

APR 82F03

9

11

APR 82F03

3

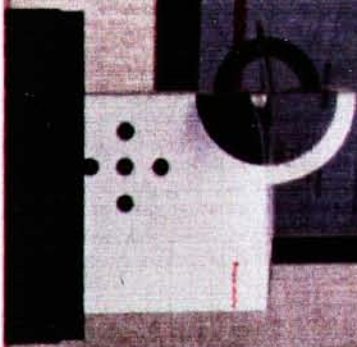
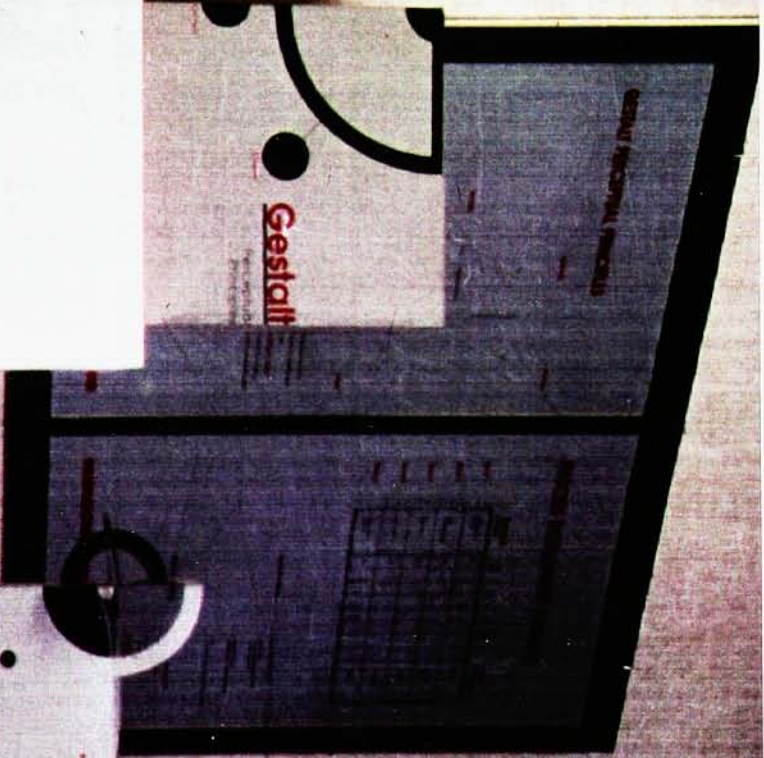
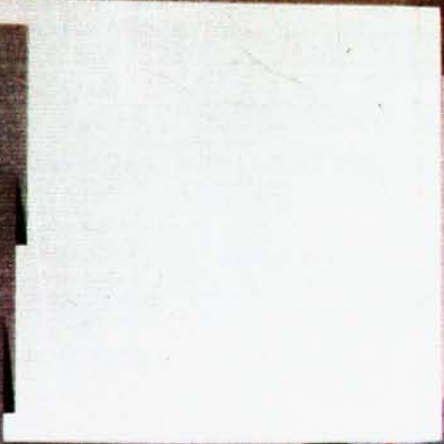

GESTALT PERCEPTUAL PRINCIPLES

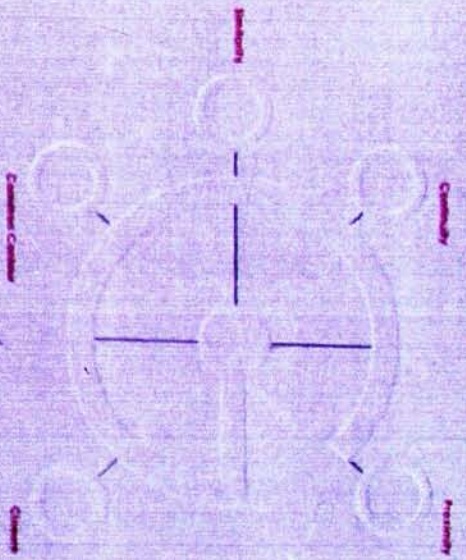

Principle of Closure: The mind tends to fill in gaps to create a whole. The overall perception is of a single, continuous shape, despite the missing segments.

Principle of Proximity: Elements that are close together are perceived as a group.

Principle of Similarity: Elements that share similar characteristics are perceived as a group.

Principle of Continuity: The mind perceives lines and shapes as continuing through one another, even when they are interrupted.

Principle of Closure: The mind perceives a shape as a whole, even when parts are missing.

Principle of Similarity: Elements that share similar characteristics are perceived as a group.

Principle of Proximity: Elements that are close together are perceived as a group.

Principle of Closure: The mind perceives a shape as a whole, even when parts are missing.

Principle of Continuity: The mind perceives lines and shapes as continuing through one another, even when they are interrupted.

The mind perceives a shape as a whole, even when parts are missing.

The mind perceives lines and shapes as continuing through one another, even when they are interrupted.

The mind perceives elements that are close together as a group.

The mind perceives elements that share similar characteristics as a group.

PROCESS DEVELOPMENT DIAGRAM

Dimensional Function	Developmental Process										Gestalt Perceptual	
	Series 1	Series 2	Series 3	Series 4	Series 5	Series 6	Series 7	Series 8	Series 9	Series 10		
1. Components	1	2	3	4	5	6	7	8	9	10	11	12
2. Dimensions	1	2	3	4	5	6	7	8	9	10	11	12
3. Series 1	1	2	3	4	5	6	7	8	9	10	11	12
4. Series 2	1	2	3	4	5	6	7	8	9	10	11	12
5. Series 3	1	2	3	4	5	6	7	8	9	10	11	12
6. Series 4	1	2	3	4	5	6	7	8	9	10	11	12
7. Series 5	1	2	3	4	5	6	7	8	9	10	11	12
8. Series 6	1	2	3	4	5	6	7	8	9	10	11	12
9. Series 7	1	2	3	4	5	6	7	8	9	10	11	12
10. Series 8	1	2	3	4	5	6	7	8	9	10	11	12
11. Series 9	1	2	3	4	5	6	7	8	9	10	11	12
12. Series 10	1	2	3	4	5	6	7	8	9	10	11	12

The Priority Process

The mind perceives a shape as a whole, even when parts are missing.

The mind perceives lines and shapes as continuing through one another, even when they are interrupted.

The mind perceives elements that are close together as a group.

The mind perceives elements that share similar characteristics as a group.

Other Considerations

Other considerations include the relationship between the different components of the process.

Other considerations include the relationship between the different components of the process.

Other considerations include the relationship between the different components of the process.

PROCESS DEVELOPMENT DIAGRAM

	Dimensional Function	Graphic Features	Texture	Formality	Color	Graphic Elements	Typographic Application	Against Ground	Gestalt Perceptual
Series 1	2-Dimensional flat form	#1	Texture	Light	Color	Dot			Closure
Series 2	Imply Dimensional form	#2							Common Contour
Series 3	Relief form	#3							Similarity
Series 4	Pop-up form	#4							Continuity
Series 5	3-Dimensional cube form	#5	Color	Dark	Formality	Cut out shape			Proximity

The Priority Process:

The relative importance of poster form:

1. Graphic Image
(Number (show the order of posters)
(Small rhapectric))
2. Typographic Definition
(Depend upon the content of each poster)
3. Color
(Use of coherent color through all series of posters)

Other Considerations:

Consider the Multiple Dimensions Theme

Graphic Image Relationship

Type Relationship
(Relating to Text)

Organizable Format
(Grids or Grid systems)

GESTALT PERCEPTUAL PRINCIPLES

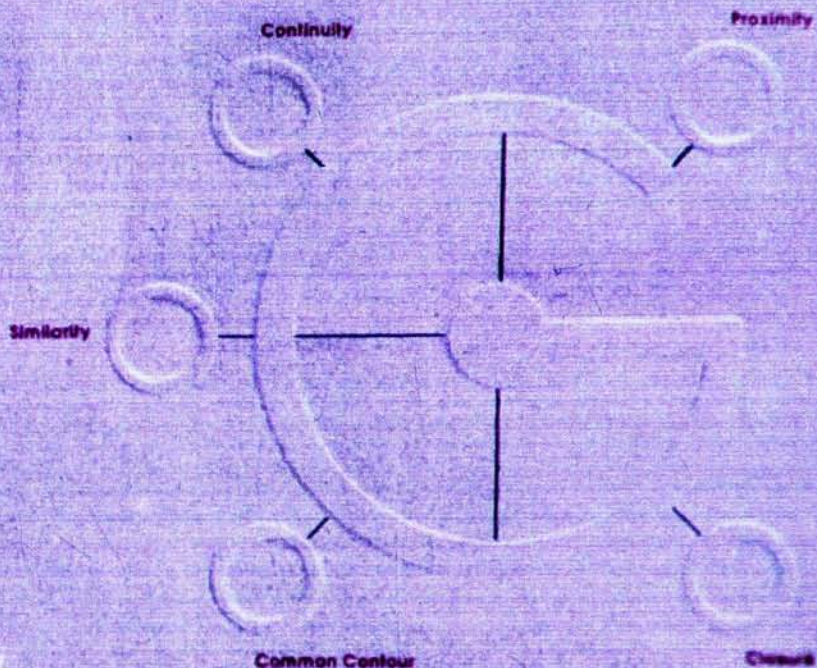

Through a unique application of the Gestalt principle, the special prototype of multiple dimensional graphic design conveys visual awareness to a wider range of graphic design audiences.

Gestalt principles are a basic theory that is based on psychological and perceptual values.

Gestalt theory relates to logical and practical applications in visual design. The basic principle is: "Images are first perceived as unified wholes before we see the parts that make up the whole."

To accomplish this, the following elementary methods for simplifying, organizing and unifying images have been utilized: closure, common contour, similarity, similarity and proximity.

The word Gestalt comes from the German and has the approximate meaning of shape, form, configuration, pattern. In terms of design it means that

"The whole is different from the sum of its parts."

A picture made up from a mosaic of lines that make up the picture -- the whole. The picture has shape, form, pattern, meaning."

...the design of the ...
...the design of the ...
...the design of the ...

...the design of the ...
...the design of the ...
...the design of the ...

...the design of the ...
...the design of the ...
...the design of the ...

Handed his Food

The picture has three ...
...the design of the ...
...the design of the ...

The word is derived from the ...
...the design of the ...
...the design of the ...

The word design comes from the ...
...the design of the ...
...the design of the ...





Principles of Perception

Gestalt

Closure

Contour

Contour



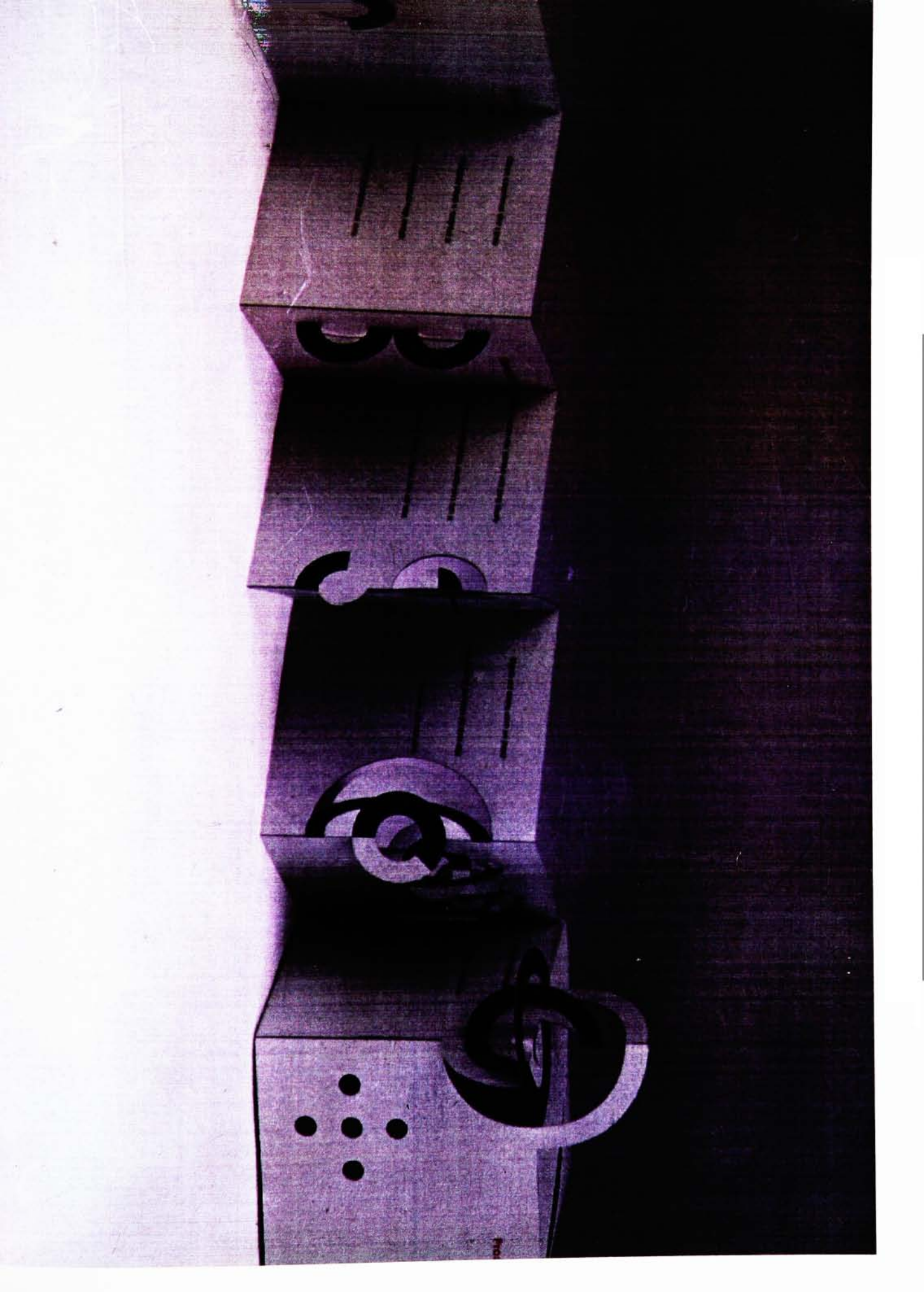

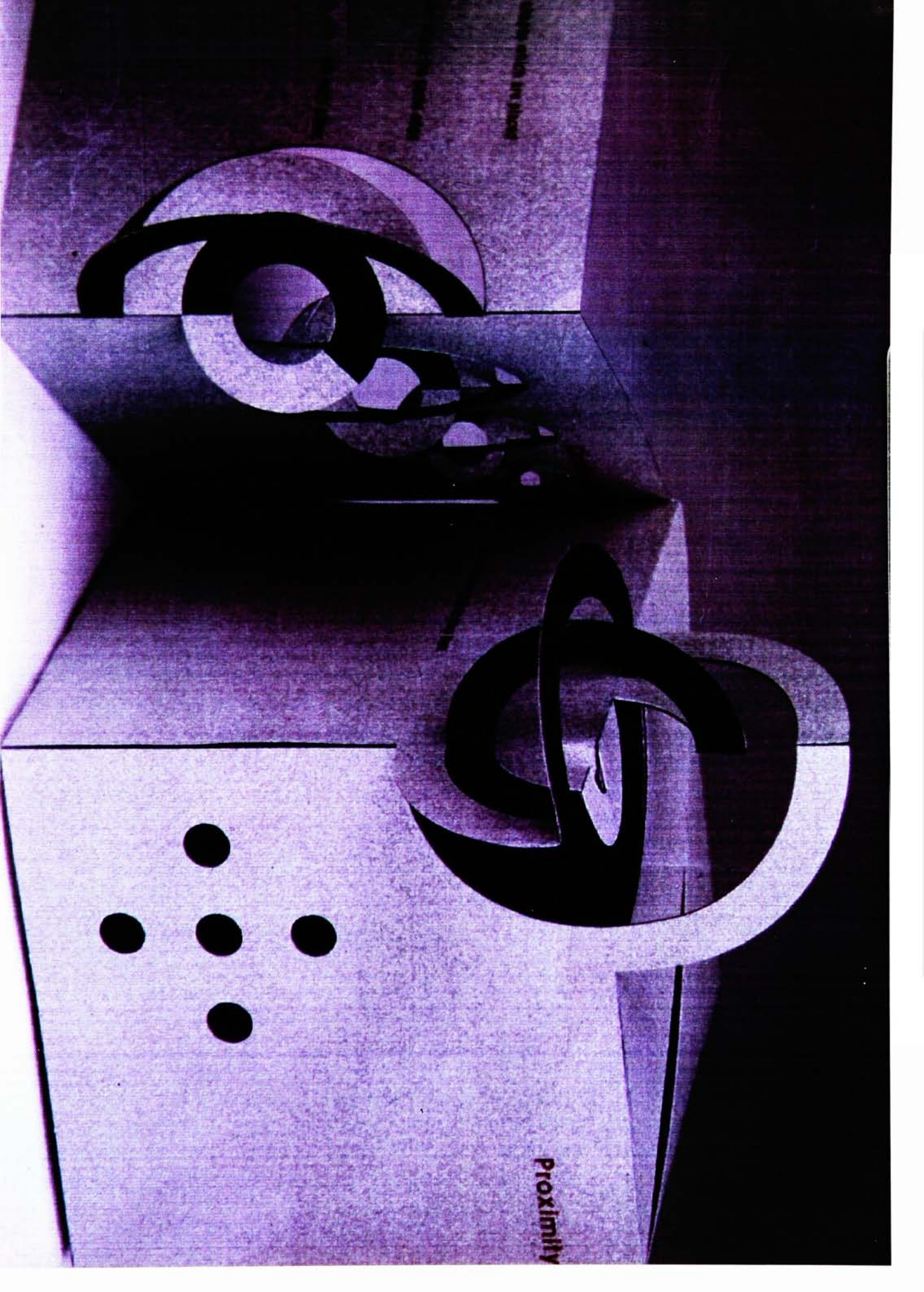

Proximity

BIBLIOGRAPHY

- Kiyotoda Ito, Sadami Yamada. New Dimension In Paper Craft. New York: Japan Publications Trading Company, 1966.
- Jackson, Paul. The Encyclopedia Of Origami& Papercraft Techniques. Pennsylvania:Running Press, 1991.
- Hiebert, Kenneth J. Graphic Design Process. New York: Van Nostrand Reinhold, 1992.
- Blommer, Carolyn M. Principles Of Visual Perception New York: Van Nostrand Reinhold, 1976.
- Amhelm, Rudolf. Art And Visual Perception: A Psychology Of The Creative Eye. California: University of California Press, 1974
- Gordon, Lan E. Theories Of Visual Perception. New York: Chichester, 1989.
- Parola, Rene. Optical Art: Theory and Practice. New York: Beekman House, 1969.
- Zeier, Franz. Paper Constructions. New York: Charles Scribner's Sons, 1974.
- Zakia, Richard D. Perception And Photography. New Jersey: Prentice-Hall, Inc.,1975.