

ROCHESTER INSTITUTE OF TECHNOLOGY

A Thesis Submitted to the Faculty of  
The College of Imaging Arts and Sciences  
In Candidacy for the Degree of  
MASTER OF FINE ARTS

ADAPTABLE RESCUE SYSTEM

by

Matthew George Goulet

March 1995

Rochester, New York

Approvals

Advisor:

Toby Thompson \_\_\_\_\_ Date: 3/30/95

Associate Advisor:

Craig McArt \_\_\_\_\_ Date: \_\_\_\_\_

Associate Advisor:

Paul Hoogestegar \_\_\_\_\_ Date \_\_\_\_\_

Department Chairperson:

Toby Thompson \_\_\_\_\_ Date: 3/30/95

I, Matthew George Goulet, prefer to be contacted each time a request for production is made. I can be reached at the following address:

3489 N. Frederick Avenue

Milwaukee, WI 53211

Date: 4/19/95

## TABLE OF CONTENTS

ACKNOWLEDGMENTS . . . . .	IV
LIST OF ILLUSTRATIONS . . . . .	V
INTRODUCTION . . . . .	1
DESIGN PLAN & SCOPE . . . . .	2
PRODUCT STATEMENT . . . . .	3
PRELIMINARY DATA GATHERING . . . . .	9
Data Gathering Procedures	
Existing Equipment	
The EMT's Working Environment	
The EMT's Health Requirements	
PRELIMINARY ANALYSIS . . . . .	19
Link Analysis	
Developing a Functional Scenario	
DESIGN DEVELOPMENT . . . . .	24
First Mock-up -- Volume Study	
From Analysis to Concept • The Mock-up -- Materials, Fabrication, Etc.	
EMT Reaction: Interviews and Questionnaires	
Second Mock-up -- Ergonomic Study	
Refining The Concept • The Mock-up • Testing	
Third Mock-up -- Final Study	
Further Refinements • Final Mock-up Construction • Presentation	
FINAL NOTES . . . . .	48
SELECTED BIBLIOGRAPHY . . . . .	51

## ACKNOWLEDGMENTS

This project could not have been completed without the help of Peter Bonnadona, Sharon Chimento, Susan Boardman and all of the other Rochester area Emergency Medical Technicians who took the time to talk about their work and answer my questions. Thanks to the faculty of the Department of Industrial, Packaging & Interior Design, for all of their input and guidance.

## LIST OF ILLUSTRATIONS

Figure		Page
1-2	Sharon Chimento's Current Solution . . . . .	10
3	Dynamics of an Emergency Medical Call . . . . .	11
4	Existing Equipment. . . . .	12
5	The Physical Characteristics of EMS Equipment . . . . .	14
6	EMT Partial Equipment List . . . . .	15
7	Military Standards For Lifting and Carrying . . . . .	17
7a	Excerpt from "Practical Guide For Manual Lifting" . . . . .	18
8	Product Link Analysis 1.0 . . . . .	20
9	Product Link Analysis 2.0 . . . . .	21
10	Preliminary "Sketching" of Volume Dynamics of ARS Volume Study . . . . .	25
11	3-Dimensional Wire frame CAD Drafting of ARS Volume Study . . . . .	25
12-15	First Mock-up: Volume Study, foam-core . . . . .	27-29
16-19	First EMT Review . . . . .	31-32
20	Preliminary Study of Second ARS Mock-up . . . . .	34
21-25	Second Mock-up: Ergonomic Study, PVC tubing, foam, acrylic . . . . .	35-38
26	3-Dimensional Wire Frame CAD Drafting of Final Mock-up . . . . .	41
27-35	Final Appearance Mock-up, acrylic . . . . .	42-46
Appendix	CAD Drafting of Proposed Adaptable Rescue System . . . . .	52

## INTRODUCTION

I began this thesis with the intention of designing a medical product. On January 1, 1994, I observed for sixteen hours on an ALS (Advanced Life Support) Ambulance with Peter Bonnadona, a certified EMT-P (Paramedic). Mr. Bonnadona trains Emergency Medical Technicians (EMTs) for certification at the Monroe Community College and also heads a 2-year degree program for paramedics. I was immediately introduced to the ambulance and all of its parts, as well as the standard procedure and basic hierarchy of EMT certification. Over the course of the first eight hours, I had several opportunities to assist, primarily by carrying around equipment.

After the first eight hours of my observing, it was apparent that the quantity of equipment these EMTs had to carry was extensive, even on the most basic call . I carried a lot of it, even though I was accompanying a team of two EMTs. Setups vary, but usually there is approximately 100 pounds of weight in equipment. Duffels, combined with tackle boxes, and oxygen tanks -- nothing is designed to be carried with anything else. But what happens when only one EMT responds to a call? This is a question that Advanced Life Support EMT-Ps face daily. There are two types of ambulances -- the Basic Life Support (BLS) and Advanced Life Support (ALS). The more experienced EMTs, with paramedic training, are often sent out in a "fly car," typically a sedan or 4x4. Riding alone, these units specialize in handling the most difficult cases, and carry even more equipment than the BLS units. In between calls, Mr. Bonnadona and I came up with a preliminary list of equipment necessary on the most basic calls, as well as commonly used secondary items. I drew up a few quick sketches of a device which might carry them: an Adaptable Rescue System (ARS). Bonnadona's face lit up and we entered into an extensive discussion of requirements, options and priorities for such a device.

## DESIGN PLAN & SCOPE

This thesis involves two main stages. The first stage is Preliminary Data Gathering and Analysis. Through reading and interviews with a variety of emergency medical personnel, I obtained additional background and understanding of the urban emergency medical system, using the metropolitan Rochester system as a model. Issues outlined in the forthcoming Design Statement were researched in depth. Preliminary analysis of this data revealed several potential solutions, leading into the second stage, Design Development.

Although these two stages are loosely bound and tend to overlap, the Design Development stage is founded in the design, construction, and analysis of three test mock-ups of the Adaptable Rescue System. Each mock-up progressively improved on the previous one. Each addressed specific issues to improve the overall concept.

The first mock-up was a Volume Study. Created in foam and other light modelbuilding materials, this mock-up flushed out the most promising solutions from the Data Gathering and Analysis stage. This study was presented to a panel of EMTs for verification of equipment volumes and priorities. A questionnaire was developed for distribution at this meeting, and responses to the mock-up were noted.

The second mock-up incorporated refinements of the initial priorities based on the input of the EMTs and faculty, and also began addressing ergonomic issues. This mock-up had sturdier, more realistic construction.

The third mock-up included refinements in ergonomics based on testing and EMT's response to the second mockup. During this final round of development, I began exploring modular design, manufacturing and marketing issues, as well as directions for the future.

## PRODUCT STATEMENT

From my observations, notes, and discussions with Peter Bonnadona, I began to formulate a preliminary design statement. This statement spelled out the problem, outlining some of the priority issues that needed to be dealt with to create a satisfactory solution.

**Objective:** To design an equipment storage/transport device or system of devices for the Emergency Medical Technician.

**Background:** The Emergency Medical Technician (EMT) is a relatively new and evolving profession. Initially, the EMT's main role was to transport an injured person or persons as quickly as possible to the nearest hospital or qualified doctor. New York State's Department of Health officially began to regulate the field in 1966, responding to a need for consistent training practices. Since then, the role of the EMT has changed and expanded as emergency techniques have improved. Training programs have become more comprehensive, and the EMT has gained more responsibility. As a Paramedic (the highest level of training), EMTs are now trained to use a variety of drugs and invasive techniques, in order to stabilize the patient. Technology has brought many new products, such as the portable defibrillator and the cellular phone, expanding the EMT's resources, and giving him or her new flexibility in the field. All of these factors have improved patient survival rates.

Ambulance crews have become more effective, but their new responsibilities have increased the amount of equipment that they must carry to the scene of an accident. Often they must carry it through large buildings or through precarious environments. Sometimes they have to take several trips back and forth from the ambulance to the scene of the accident. This compromises their effectiveness, as time is so often critical. Thus, there is a clear need to develop a device or system of devices, that enable the EMTs to organize, transport, and access that equipment more efficiently.



## 1.0 Issue: Portability

1.1 Background: Currently, there are a few key pieces of equipment that go to every call: the trauma bag (which holds bandages, stethoscope, oxygen tank, other special equipment, in a 10"x10"x36" duffel bag), the portable defibrillator/heart monitor, and the drug box (standard orange tackle box, 10"x10"x20"). Usually, two people can carry all of it, but often times there is only one EMT. Some EMTs may not be as physically strong as others.

1.2 Design Objective: Make the equipment easier to carry.

1.3 Implications:

- Transport device(s) should hold the majority of equipment.
- Transport device(s) should not require great strength to use.

## 2.0 Issue: Flexibility

1.2 Background: Each local district has its own regulations on what should be carried, and each EMT needs to customize the equipment to meet these standards, as well as his or her own personal preferences. Advanced Life Support units (as opposed to the Basic Life Support unit) must carry additional equipment. While some equipment has reached a level of standardization (such as the defibrillator), other equipment and supplies come in a variety of forms.

2.3 Design Objective: The transport device should accept different types of equipment.

2.4 Implications:

- Transport device should be modular.
- Device should meet basic needs but make allowances for new and different equipment.
- Device should have the ability to accept non-standardized equipment.

### 3.0 Issue: Functionality, Accessibility, & Efficiency

3.1 Background: All equipment designed for the EMT has function as the primary goal. To sacrifice function would be unthinkable. Equipment which looks nice but doesn't work well, is not used.

3.2 Design Objective: Device must always clearly keep function as the priority.

3.3 Implications:

- Device must not impede accessibility to equipment, or efficiency.
- Device must not sacrifice function for aesthetic concerns.

### 4.0 Issue: Ergonomics

4.1 Background: There are many different shapes of human beings, and there are just as many shapes of EMTs. The equipment is heavy enough as it is. How can it all be removed from the ambulance at once? Do you wear it as a vest? Does it roll? Whatever the case, it must be usable by a variety of people.

4.2 Design Objective: Device must be usable by any EMT.

4.3 Implications:

- Weight of the device should be kept at a minimum.
- Device should show attention to physiological variation.

### 5.0 Issue: Protection

5.1 Background: Much of the equipment, such as the bandages, needles and drugs, must be kept sterile. Needles and drugs are often stolen, so there is a security problem. The electronics and high voltages of the defibrillator should be protected from the environment. All of the equipment should generally be kept sanitary. If this device must go up ten flights of stairs, the equipment should both stay in the transport unit and be protected from the impacts.

5.2 Design Objective: Device should be secure and sanitary.

### 5.3 Implications:

- Device should be made of impact-resistant materials.
- Device should be secured by some sort of lock mechanism.
- Device should have easy-to-clean surfaces.
- Device should be watertight.
- Device should lessen impacts through shock-absorbing bumpers.

### 6.0 Issue: Stability

6.1 Background: The back of a moving ambulance is not a stable platform. There should be no reason for this device to fall over if the ambulance turns quickly or brakes abruptly. In the rush of a crisis, no one wants to worry whether the drugs are going to spill. At the accident site, there may be no flat ground to put an unstable device and no one wants to bump into it.

6.2 Design Objective: The Device must be stable.

### 6.3 Implications:

- Device should have a low center of gravity.
- Device should operate effectively from as many angles as possible.
- Devices could lock down in ambulance or to the wall.

### 7.0 Issue: Environment

7.1 Background: EMTs are required to work in any environment, from a crumpled auto to a burning building to a rural farm in the middle of winter. There is snow, mud, stairways, small passageways and cold and heat to contend with.

7.2 Design Objective: Device should operate under extreme conditions.

### 7.3 Implications:

- Mechanisms must not be susceptible to snow, rain or mud.
- Device should be compact.

## 8.0 Issue: Color

8.1 Background: Over the years a level of standardization has occurred with some products and equipment in emergency medical service. Bright colors are most often used, simply because they are easy to locate quickly. Orange is associated directly with the drug box in Monroe County.

### 8.2 Design Objective:

Device should use color to increase the efficiency of the EMT.

### 8.3 Implications:

- Coloration of the device should use current standards where possible.
- Where no standards apply, coloration should use intuitive logic.

## DATA GATHERING PROCEDURE

It should be noted that interaction with Emergency Medical Personnel such as Peter Bonnadona and Sharon Chimento was critical to the development of this thesis. Without their help this project could not have happened. In early January, following my eye-opening ride with the Monroe Ambulance Co., I arranged several meetings with Mr. Bonnadona, who provided examples of existing equipment and suggestions to further my research. This also allowed me to develop a historical understanding of the EMS, which goes largely undocumented. His experience has been a great asset, and his own interest in developing new equipment has made him an understanding mentor. A pioneer of sorts, Sharon Chimento, a full EMT-P (Paramedic), actually uses a luggage cart to move her equipment around. Driving the Gates Ambulance Service's ALS unit, Sharon is only 4'11" tall, and an example of a fifth-percentile female. Information was also gathered by investigating RIT's own fully-accredited ambulance corp.

Due to the "newness" of the EMS, literature was limited. Journals and government documents such as the New York State Emergency Medical Services Code (known as "Part 800") laid the groundwork for equipment requirements, which are very specific, as well as the EMT hierarchy and training requirements. Also helpful was the National Safety Council's annual "Accident Facts" report, which summarized accident trends and numbers on a national level. Several anthropometrics volumes were researched as well.

## EXISTING EQUIPMENT

There is a direct correlation between the development of emergency medical procedures and the evolution of emergency medical equipment. Procedures have changed over the last ten years. Legislation has defined and redefined the responsibilities and limitations of an Emergency Medical Technician. Technological developments have made some procedures possible in the field for the first time. Amid these changes, there are always key items to a certified EMT's equipment list. Most EMTs carry this fundamental equipment:

The Trauma Bag is at the top of any Technician's list and contains the basic sterile pads, bandages, shears, pressure cuff, rubber gloves, stethoscope, etc. New York State has a required list of supplies, including quantities, that is usually carried in this bag. Typically, it is a medium duffel (about 15" diameter, 30" long) in blue, orange or green. Non-certified teams carry smaller ones, but some certified teams carry much larger ones meant to consolidate all of the equipment below in one package. These bags weigh well over 50 pounds loaded and they are cumbersome. There is interest in an all-in-one package, but so far the solutions have been only partially effective, ignoring the consequences to the carrier, who must lift a 50 pound bag by two flat nylon straps. As new equipment is incorporated, the smaller items usually go into this bag, which is carried to all emergency calls.

If the EMTs determine that a patient needs to be transported to a hospital for further medical treatment, a Gurney is used. Typical gurneys are made of steel tubing and have a variety of adjustable features. This piece of equipment is not generally brought to the site of the accident until the patient has been examined. Nevertheless, the gurney does interact with other pieces of equipment during the process of transporting the patient (see figure 3, Dynamics of an Emergency Medical Call).

One piece of equipment which interacts with the gurney is the Oxygen Tank. The medical size "D" tank is a steel cylinder approximately 4-1/2" in diameter, 20" tall, and



Figure 1. EMT Sharon Chimento's luggage cart from front view, fully loaded.



Figure 2. EMT luggage cart from rear fully loaded.

1. An accident occurs; someone calls 911.

2. 911 operator directs the call to the general Dispatcher, who relays the call to an Ambulance Company, who contacts the closest Ambulance.

3. The Ambulance arrives on the scene, the EMT brings: Trauma Bag, Drug Box, Oxygen Tank, Defibrillator, Phone, and other equipment as necessary. Determines the need to call for back-up.

4. EMT does a patient examination; checks vital signs; stabilizes patient if possible; calls Hospital; determines whether patient needs to go to Hospital.

5. If the patient needs to go to the hospital: the Gurney is retrieved from the ambulance.

6. The patient is transported to the Ambulance; Oxygen Tank and Defibrillator stay with the patient on the Gurney; other equipment goes back in the Ambulance.

7. Ambulance goes to Emergency Room at the Hospital.

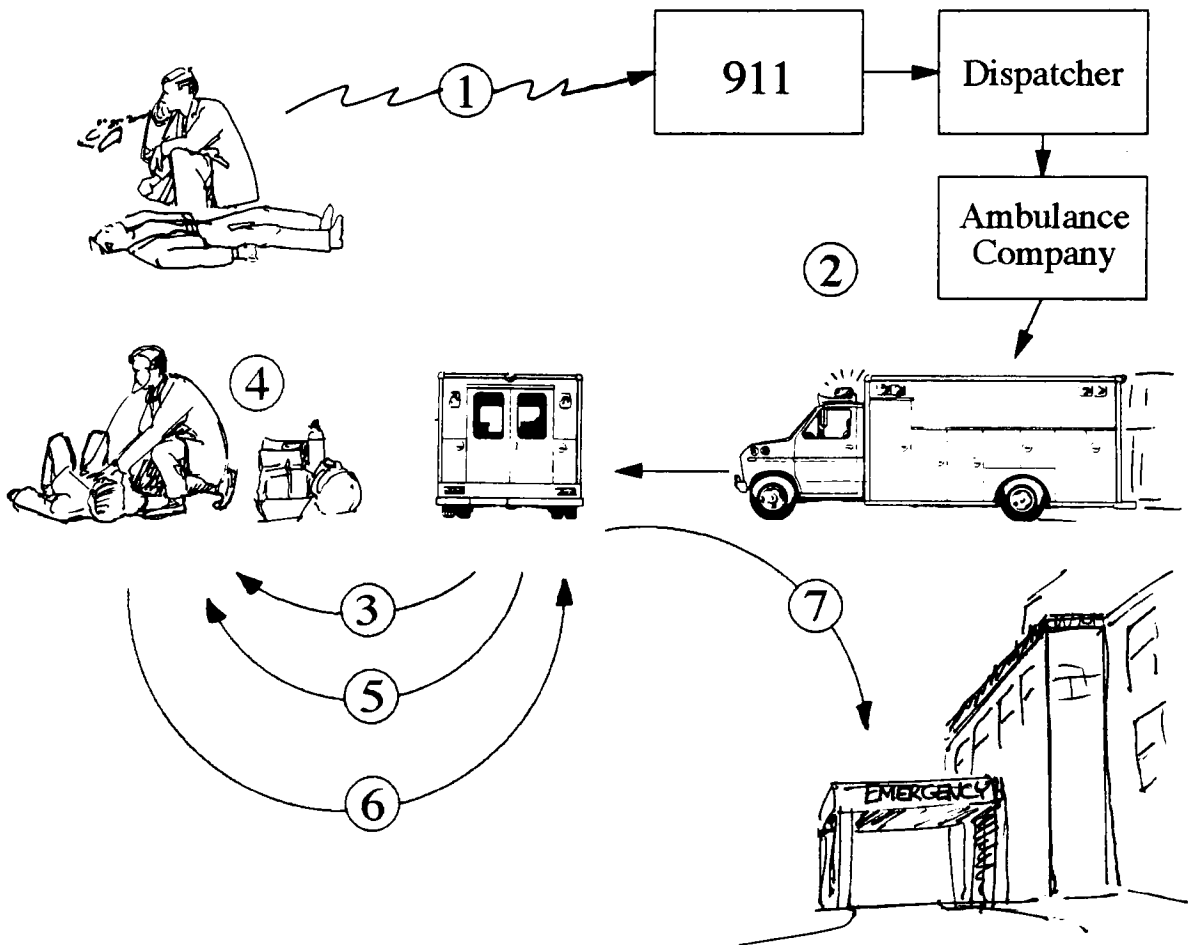

Figure 3. Dynamics of an Emergency Medical Call





Figure 4. Existing equipment: front left, Drug Box; front right, ILS Box (part of additional equipment); top left, Oxygen Tank; middle left (blue bag), Trauma Bag; back right, Portable Defibrillator.

includes a pressure regulator. There are several derivatives, such as the Super D, which is the same diameter, but 50% taller. What is important to note about the oxygen tank is that while it goes in with the EMT, it often leaves attached to the patient, and must be loaded at the head of the gurney or between the legs of the patient, or worse, just carried by someone. Additionally, if the call is a long one, more than one tank may be required. Typically, the oxygen from a "D" tank will last approximately 20 minutes.

The portable Defibrillator/Heart Monitor is a relatively recent technological development. Twenty years ago defibrillators were bulky and not portable. Used in cases of cardiac arrest, as well as for general monitoring, they are now required for every call. Legally, less experienced EMTs were not allowed to use defibrillators 10 years ago, but currently, the defibrillator is introduced earlier in the training process. All but beginners are familiar with them at this point. Full-featured models are reaching a standardized size around 20" x 5" x 15." There are smaller automatic models on the market for use by less experienced EMTs. Just like the oxygen tank, the defibrillator is often attached to the patient on the way to the hospital -- an issue which should be accounted for in the design of any carryall. This is also a fragile piece of electronics, which can deliver 2000 volts if not handled respectfully. It should be protected from the environment. In addition, cellular phones are carried in order to send the recorded heart rate ahead to the hospital for analysis by the supervising doctor, and should be taken into account. The cellular phone is now a permanent feature for many EMTs. While allowing communication of the vital signs, the EMT can also talk to the doctor on scene instead of running to the radio.

Another key piece of equipment is the Drug Box. Originally just a small "tackle" box containing a few drugs, it is now a much larger box with many drugs available to those who are trained to use them. Currently, they run about 15" x 15" x 20" (with an orange color in the Rochester community). No drugs were used in the early days, but now the EMT-P (Paramedic) has gained training with many drugs. Medicine is still changing and all EMTs must educate themselves about new drugs (even the highest level EMT must pass

recertification every 37 months). Considerations to be addressed include security and sterility. Another factor in the Rochester community is that all drug boxes are owned and maintained by the hospitals, instead of being owned by the ambulance company.

Introducing a new design would mean approaching the hospital system for approval. Any carryall must make allowances for the current drug boxes if a new design cannot be introduced.

These are the key items that must be carried to all emergency calls. Other equipment such as manual or electric suction, and intravenous liquids are brought when required and every EMT prefers to customize his or her load to some extent. I obtained approximate weight and dimensions of each piece of equipment, as well as an idea of the fragility and basic usage, in order to better plan for its storage and transport. I researched other carrying setups available on the market, primarily of the duffel type. The most forward-thinking was an adaptation of airline luggage (with wheels) called MegaCode, just recently released. It was a step in the right direction, in that it had wheels, but failed to meet other important objectives.

Physical Characteristics of EMS ALS Medical Equipment:

Description	% Used	Fragility*	Weight
Drug Box	25%	2	15 lb.
Duffel/Trauma Bag	100%	2	20 lb.
Intermediate Life Support Box (ILS)	(?)	2	30 lb.
Defibrillator/Heart Monitor	100%	5	30 lb.
Cellular Phone	100 %	4	1 lb.
Oxygen Tank/Regulator	100 %	3	5 lb.
TOTAL WEIGHT ---->			101 lb.

Figure 5. Summary of Physical Characteristics of EMS Medical Equipment  
 \* Fragility rated from 1-5 with a 1 rating being durable, a 5 rating being fragile.

## EMT EQUIPMENT LIST

Trauma Bag: Typically a blue duffel bag, approx. 15" x 15" x 30" serviced by the ambulance service and includes:

- 24 sterile gauze pads 4" x 4"
- 3 rolls of adhesive tape in 2 or more sizes
- 10 rolls of conforming gz. bandages in 2 or more sizes
- 2 sterile universal dressings, 10" x 30"
- bandage shears
- bed sized burn sheets
- triangular bandages
- pressure cuff for adults and children
- stethoscope
- 2 sets of masks/goggles
- 2 pr. disposable rubber gloves
- sanitary napkins
- Manual adult bag valve ventilation device
- 4 oropharygeal airways(adult)
- 4 non-rebreather masks, 4 nasal cannulae
- portable suction, manual or mech.

Medical 'D' sized Oxygen Tank w/ gauge, regulator, and flow meter.

Drug Box: a 15" x 15" x 30" tackle box, owned and serviced by the local hospitals in the 9 county area(this is unusual).

Defibrillator/Heart Monitor: 20" x 6" x 15" casing, portable with rechargeable battery pack.

Figure 6. EMT Required Equipment List, based on New York State Health & Safety Code, Part 800

## THE WORKING ENVIRONMENT

The EMT has a wide range of environmental issues to contend with. Accidents, of course, can happen at any time. Certain settings are more dangerous. The National Safety Council divides accidents into four primary divisions: Motor Vehicle Accidents, Accidents at the Work Place, Accidents at Home, and Public Accidents.

- 36% of all accidents resulting in disabling injury occur in the home.
- 26% of all accidents resulting in disabling injury occur in public.
- 19% of all accidents resulting in disabling injury occur in the work place.
- 18% of all accidents resulting in disabling injury occur in motor vehicles.

Urban homes are generally smaller, and may have narrower stairways. Obviously, high-rise apartment buildings are more likely in the city. In an emergency, the EMT may have to move the patient as well as his or her equipment up and down stairs. In a business district, office buildings offer the same problems. Homes come in many shapes and sizes. Suburban and rural homes tend to be larger inside than the older homes typical of the urban core. Rural homes are naturally more isolated, and may be more difficult to get to in bad weather if the roads are poorly maintained.

Public accidents could include those at a stadium, arena, street intersection, restaurant, bar, or a park; conditions such as a crowd, the physical distances to be traveled in a stadium, or the terrain of a forest all must be taken into account by the EMT.

The Work Place can be anything from a tire factory to a 30 story business building, to a sewer pipe, to a construction zone, each with its own hazards.

Motor Vehicle accidents can involve cars, but might involve tractors or motorcycles, each with its own dangers, including gasoline leaks, surrounding traffic, poor weather, and crushed vehicles.

What we see here is a great variety of possible circumstances under which the EMT may be forced to do his job. Flexibility is crucial and must carry through in the design of all of his equipment. This carryall should function efficiently in a variety of environments:

- carried on an EMT's back, perhaps, through woods, or up stairs.
- rolled down long hallways, through large buildings.
- squeezed through tight passages and stairwells.
- brought downstairs ( but not on an EMT's back).
- dragged through rough terrain (snow, mud, mine shafts, lakes, rivers, mountain paths).
- hoisted on a rope up or down to stranded patients (cliffs, apartment in a fire, etc.).
- strapped to a moving gurney.

### HEALTH GUIDELINES

From the outset, it was clear that there was a lot of equipment to carry -- over 100 pounds worth. The next step was to investigate human lifting and carrying limits, to see how they compared to the amount of weight the EMTs are required to carry.

The US Military Standard provides the following limitations:

#### Human Strength: Carrying Capacities

##### Maximum Load Lift Limits:

Lifting object from the ground to a height of 3 ft.:

- 44 lb. for males & females \*
- 87 lb. for males only \*

Carrying object up to 33 ft.:

- 42 lb. for males & females \*
- 82 lb. for males only \*

\* These maximum limits apply to 1 lift every 5 minutes

Figure 7. Military Lifting and Carrying Limits according to Military Standard MIL-STD-1472D (Human Factors, pg. 623)

This means that a healthy US Army male should only carry 82 pounds over 33 ft every five minutes. Not only is the 100 pounds well over the limit, but oftentimes an EMT must carry his supplies a considerable distance. The real problem is that EMTs are not all healthy US Army soldiers. Many are volunteers or work only on a part time basis, and do not maintain an exercise regimen. There are many women in the emergency medical service, and the fact is that their average physical limits are less.

These findings are reinforced by an excerpt from the National Institute of Safety and Health's "Work Practices Guide for Manual Lifting."

- Carrying a suitcase-type object with a handle and smooth sides, the maximum weight a male should carry is 45 lb., females 40 lb..
- Backpacks should weight no more than 45-50 lb. for males, and 35-40 lb. for females
- A package is generally considered "heavy" when it reaches 35% of the person's body weight.

#### Figure 7a. Work Practices for Manual Lifting

Here we find actual limits for suitcase type objects and backpacks. Thus, the weight issue must become a major concern, because right now EMTs all across the United States are carrying an unreasonable amount of weight on a regular basis, or they are being hindered at critical moments by having to take several trips back and forth to the ambulance.

## PRELIMINARY ANALYSIS: LINK ANALYSIS

This technique is used to develop an efficient arrangement in any complex human/machine interface. In this case, the functional scenario will include all of the existing equipment mentioned above, plus one accident victim, one Emergency Medical Technician, and an assisting doctor at the hospital. In determining the design, elements must be arranged where they can be efficiently accessed at the accident scene.

Links can occur between humans and machines, humans and humans, and machines and machines. There are three types of links: visual, audio, and tactile. Each link is rated in two ways: how often the link is required, and how important the link is to the completion of the mission (rated from 1-3, 3 being most important). For example, the EMT must be able to talk to the patient at all times (3) and it is very important to the mission (3). The total value of the link is found by multiplying the two ratings together ( $3 \times 3 = 9$ ).

An analysis chart can be started with the EMT and the patient. All three types of links would ideally be established between the EMT and the patient. Each of the items that go in the storage unit/carryall are positioned around these two (see Product Link Analysis 1.0). Links are established where appropriate, between the equipment and the EMT and the patient. Certain products, such as the Cellular Phone and the Defibrillator, may be linked together. This preliminary arrangement shows all of the necessary links and begins to highlight conflicts where the links cross or travel long paths.

Relationships can be drawn between pieces of equipment that have similar sets of links. In this case, The Trauma Bag and the Drug Box play similar roles in that they are contacted only by the EMT, who then uses his links to the Patient to administer care. Similarly, the oxygen tank and the defibrillator have matching links to both humans, and both end up traveling with the patient to the hospital. The cellular phone plays a central role in communications between the EMT and the Doctor, as well as to the doctor from the defibrillator.



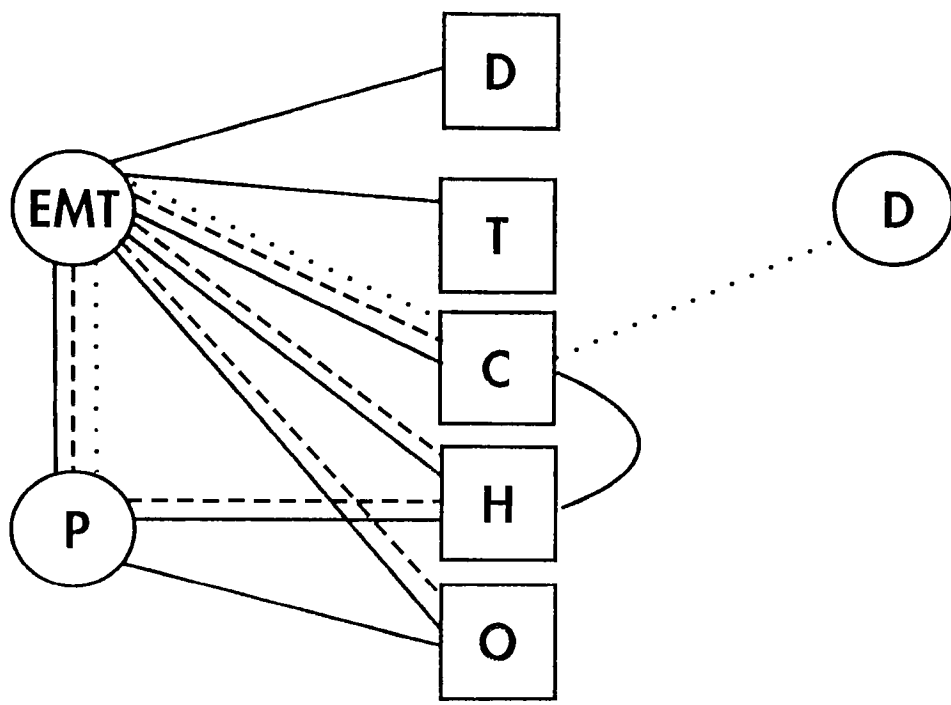

**Personnel:**

- (EMT) Primary Emergency Medical Technician
- (E2) Secondary Emergency Medical Technician
- (P) Patient
- (D) Emergency Department at Hospital

**Equipment:**

- (D) Drug Bag
- (T) Trauma Bag
- (O) Oxygen System
- (H) Heart Monitor/Defibrillator
- (C) Cellular Phone

Figure 8. Product Link Analysis 1.0

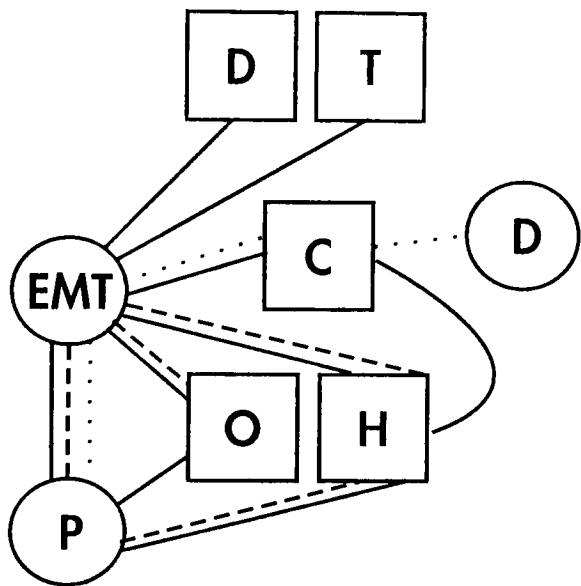

**Equipment:**

- (D) Drug Bag
- (T) Trauma Bag
- (O) Oxygen System
- (H) Heart Monitor/Defibrillator
- (C) Cellular Phone

**Personnel:**

- (EMT) Primary Emergency Medical Technician
- (E2) Secondary Emergency Medical Technician
- (P) Patient
- (D) Emergency Department at Hospital

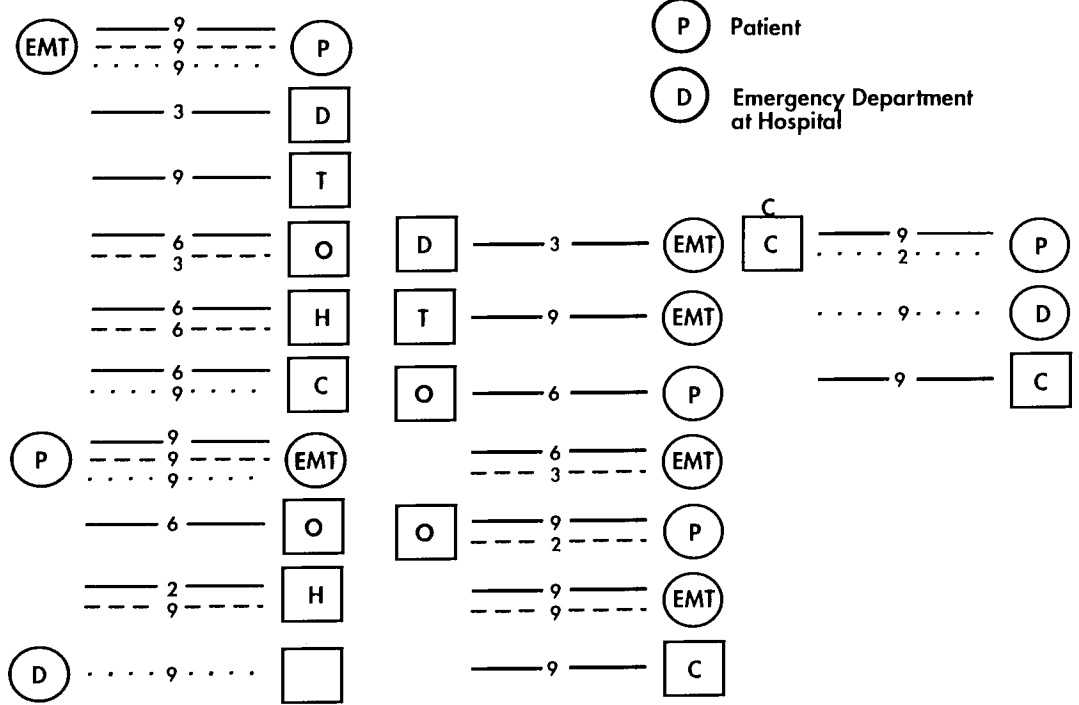

Figure 9. Product Link Analysis 2.0

From the first arrangement, evolves a second plan, which is more compact and begins to suggest how different elements might work together more efficiently. This second plan is fine-tuned as ratings are assessed to each link (see figure 9, Product Link Analysis 2.0).

## DEVELOPMENT OF A FUNCTIONAL SCENARIO

The functional scenario takes the link analysis results and applies weight and carrying capacities and scale to the most efficient arrangement derived. Several different loading options are assessed for feasibility.

## LAYOUT VARIATIONS

The EMT, in worst case scenario (trauma victim requiring Intermediate Life Support), is required to carry a Drug Box and ILS in one hand and a trauma duffel and defibrillator in the other, totaling 101 lb., well over any lifting/carrying limits established by Military Standard or the National Institute of Safety and Health. The equipment is very heavy (35% of body weight is considered heavy) and not designed to be carried in this fashion (items of equipment are not smooth-sided, designed to be carried one object per hand). The list of equipment EMTs carry is not only excessive, but it continues to grow with state regulation and new product development.

Layout 1: Device divided into two basic units: Pack Unit and Defibrillator Unit, per link analysis results. Pack includes the main frame of the device and the Drug Box, Duffel, and ILS storage, and weighs approximately 65 pounds. Defibrillator Unit includes the Oxygen Tank, Defibrillator, and Cellular Phone and weighs 36 pounds. Under the optimal conditions, Defibrillator Unit attaches to the underside of the Pack Unit and rolls behind the EMT, and the entire unit weighs 101 pounds. This device could be designed to ease transport up and down stairways. When conditions do not permit rolling to the scene, a secondary configuration would put the Defibrillator Unit in one hand (36 pounds), ILS in

the other (30 pounds), and the remaining elements of the pack unit on the back (35 pounds), evenly distributing the weight and bulk (which as a whole could not be moved). If the decision is made that the patient must be transported to the hospital, the Gurney is retrieved from the ambulance. Once the patient is loaded on the Gurney, the Defibrillator Unit attaches to head of the Gurney.

Layout 2: Drug Box (15 pounds) in one hand, ILS (30 pounds) in the other, with Pack unit carrying Phone, Duffel, Defibrillator, and Oxygen Tank (56 pounds). Since the Drug Box and ILS are options, and independent from other items, this layout is plausible if the weight of the remaining pack can be reduced to under 40 pounds. Phone, Oxygen and Defibrillator are a unit in that they link to the patient and EMT similarly, as well as to each other (Phone and Defibrillator are connected).

Layout 3: All equipment on back (101 pounds) clearly exceeds limitations for backpack ergonomics established by the National Institute for Safety and Health.

Layout 4: This device might incorporate a vest and /or belt pack. The idea would be that the EMT would have direct access to some of his most basic equipment in vest storage. This feature could be added to Layout 1, to provide a more efficient solution. It would not be necessary for the EMT to wear this vest constantly.

In general, there is still far too much weight to be carried. Concentration on weight reduction through the use of new materials should yield improvement, as should continuing study of human ergonomics. In the ideal situation, wheels would reduce strain, but the object of the design is that it must be flexible enough to be functional even when there are obstacles to the cart option. Carrying must be carefully thought out to provide the least amount of physical stress in an inevitably straining situation.

## DESIGN DEVELOPMENT: FROM ANALYSIS TO CONCEPT

From research to concept is a large step. The initial kernel of an idea has expanded. Priorities have been defined. EMTs have helped to define equipment needs and the manner in which those pieces of equipment interact. In order to verify my preliminary conclusions, the first step will be to conduct a volume study. This study will include the working elements as they exist (to be verified). The best hypothetical functional scenario has been established; now, for the first time it will be drawn out to scale on a CAD system, yielding a functional form to support the equipment. Familiarity with the Macintosh and Ashlar 3D-Vellum will allow me the freedom to "sketch" the first form and then manipulate its basic mechanics. Since the Drug Box and the Trauma Bag are always carried together, they form a unit on the "frame," which can function both as a cart and as a backpack as conditions require. While functioning as a cart, the Oxygen Tank and Defibrillator can be stowed on the inside face of the cart, protected by the side flanges which hold the extension arms of the wheel bracket. Oxygen Tank, Defibrillator and Cellular Phone form a second unit which must be removed from the frame if the unit is to be carried on the back. This prevents the EMT from putting excessive strain on his or her back, per layout 1. The wheels lower to provide a second shelf for storing additional equipment; the Oxygen /Defibrillator Unit could be carried in one hand. The flanges extend out past the wheels to provide protection for the Defibrillator while going upstairs, or if the unit must lay flat. These items yield minimum dimensions for the frame unit itself which are then input into the computer and manipulated before actual construction begins.

The development of modules in the link analysis and function scenario lead directly into the evolution of the first concept, which is the preliminary volume study. Priorities established in the interviews and observations lead to my preliminary assessment, to link valuation, which drive module placement. Evaluation of existing equipment provides boundaries in the functional scenario when cross-referenced with human lifting/carrying limitations.

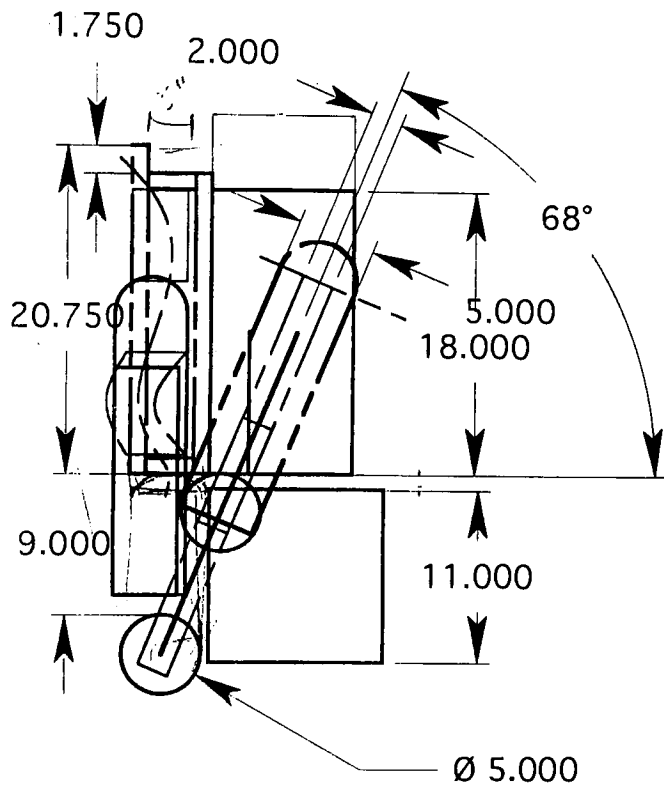

Figure 10. Preliminary "Sketch" of ARS Volume Dynamics

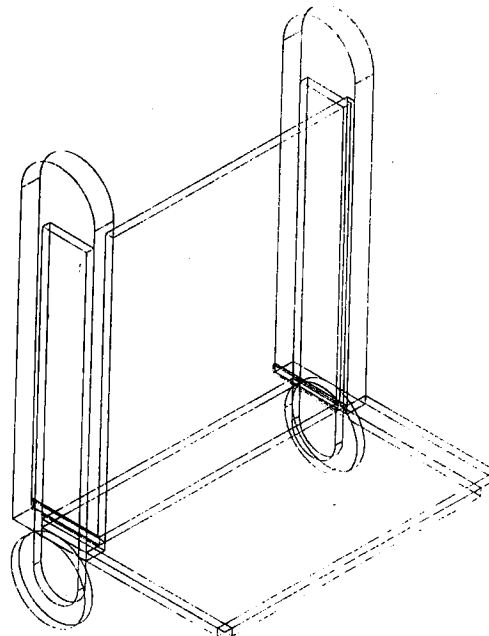

Figure 11. Wireframe CAD Drafting of ARS Volume Study

## THE MODEL - MATERIALS, FABRICATION, ETC.

The model was constructed entirely out of foamcore board. First, existing equipment such as the Defibrillator and Oxygen Tank were modeled. Volumes were constructed to represent the Drug Box and Trauma Bag. An Intermediate Life Support Box was constructed as an example of a piece of equipment that was not always carried. All were constructed out of foam or foamcore and bonded with hot glue. When a satisfactory design was completed, the construction began. The rough mechanism for lowering the wheel functioned as did the wheels themselves. Once the mockup was complete, I documented it fully on film, and plotted a dynamic layout on the computer. The entire mockup was white.

## THE FIRST REVIEW

The first review was perhaps the most interesting one. Meeting with five EMTs, four of whom had paramedic certification, I presented the entire concept, since several of them had never seen the project. The presentation allowed them to follow my path of development, check my priorities and understanding of the situation. I demonstrated the function and logic behind the mockup and then let them "play" with it. A list of prepared questions were presented. Photos were taken, and notes on the running dialogue that developed were made as well. In the end, a questionnaire was handed out, with questions ranging from the technical and specific to the philosophical and general.

## THE SECOND MODEL: ERGONOMIC STUDY

### REFINING THE CONCEPT

I was pleased that my presentation -- as I had hoped -- fostered a dialogue. The EMTs began to debate issues, and I tried to direct the flow of discussion by asking more

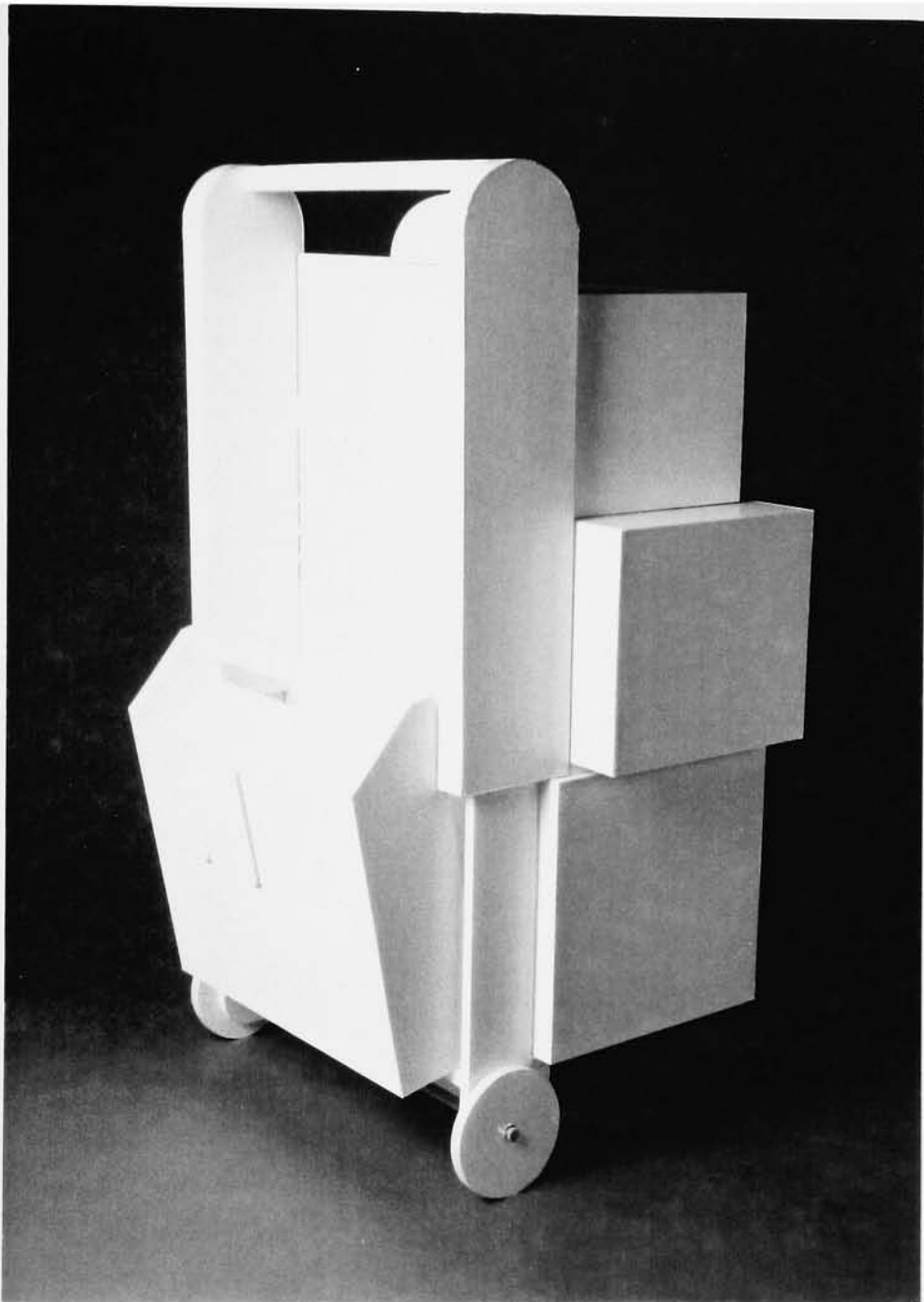

Figure 12. First Mock-up of ARS: Volume study, loaded with Defibrillator, Drug Box, Trauma Bag and ILS volume representations



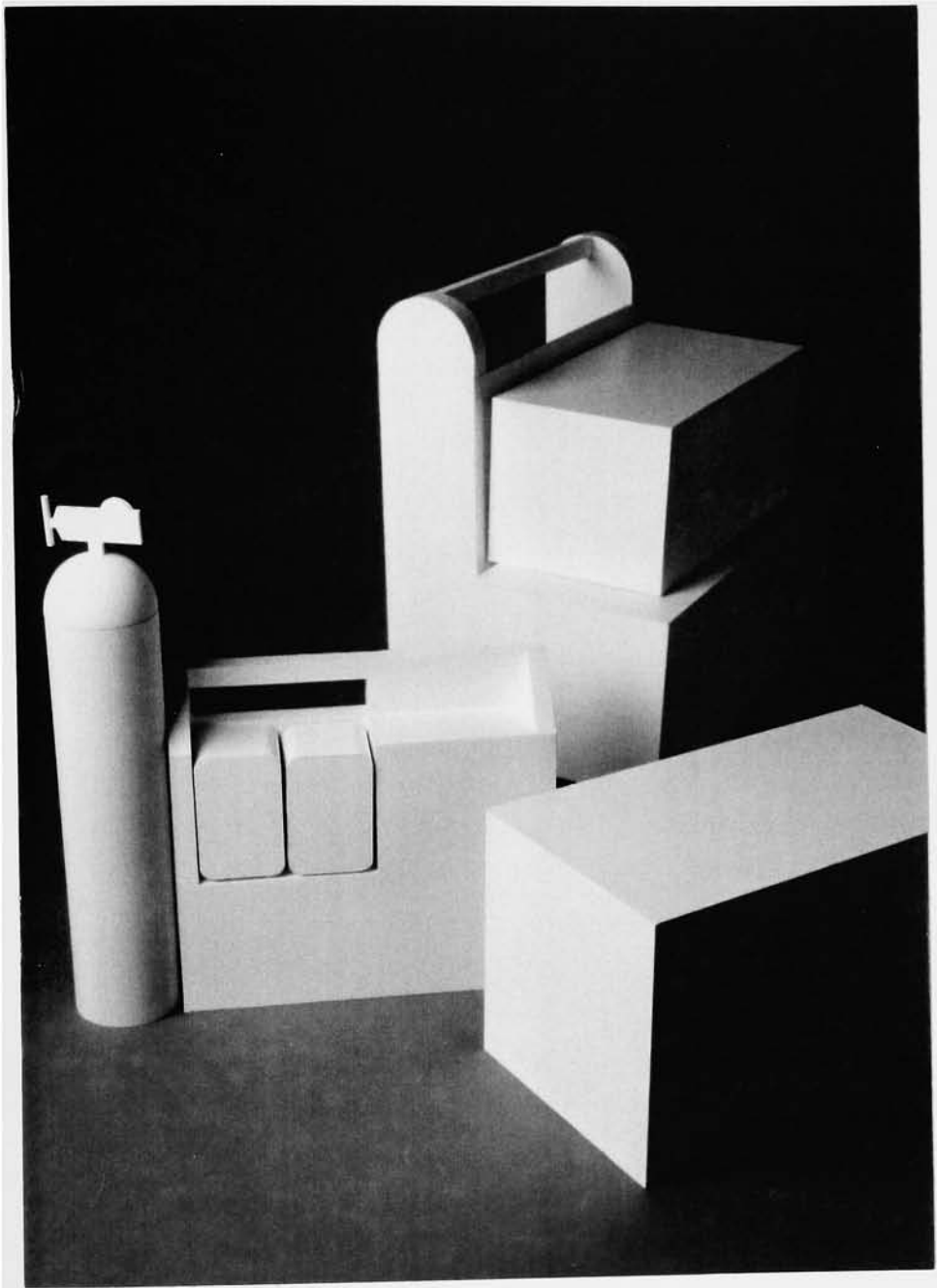

Figure 13. First Mock-up of ARS with Defibrillator, Drug Box, Trauma Bag, Oxygen Tank and ILS volume representations

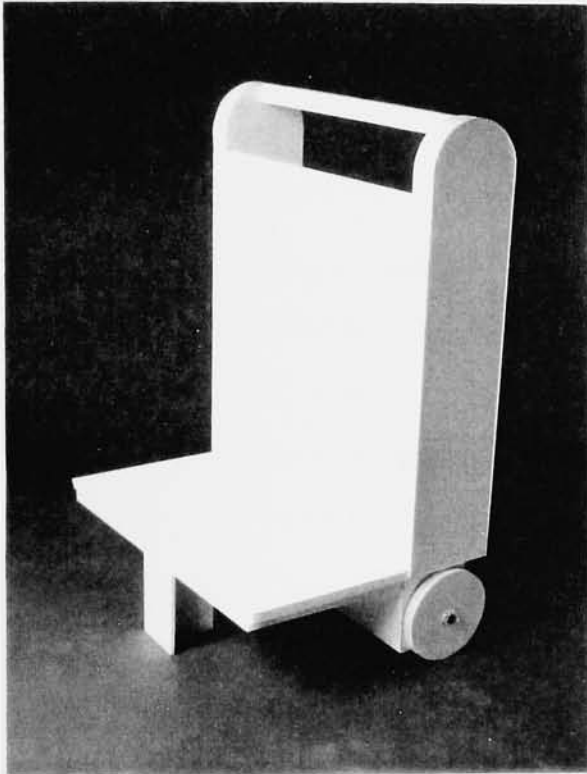

Figure 14. Volume Study with wheel units retracted to function as a backpack.

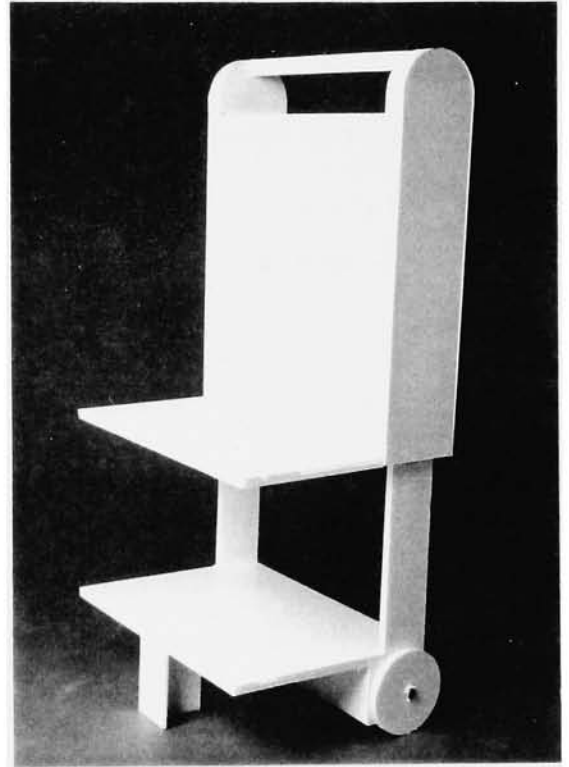

Figure 15. Volume study with wheel unit extended to hold additional equipment while functioning as a cart.

questions. This EMT review provided a lot of positive feedback, confirming my belief that there was a need for the device. Several interesting points were made:

- Sharon Chimento had earlier mentioned a piece of equipment, the Intermediate Life Support (ILS), which holds various intravenous liquids, etc. There was discussion at this meeting that ILS boxes were no longer going to be included as standard equipment. Subsequently, I choose to treat the ILS box as an "additional" piece of equipment.
- I got some useful feedback on how the carrier might be loaded into a Flycar (a sedan). The universal consensus was that most of the equipment would be loaded on scene.
- We discussed what sort of "backpack" attachments might be used to make picking up the unit easier. The EMTs came up with a hook-shaped concept that would be tested in the second model.
- Going down stairs with a large amount of weight on your back is difficult.
- Pulling the cart downstairs could be difficult.
- Volumes (and later weights) of equipment were verified.
- Priorities in terms of equipment were verified
- We discussed a new strategy for expanding the capacity of the unit. It became clear that, instead of lifting the mass of the unit upward while holding down the wheel axle, the mass of the unit should remain stationary, as the handle pulled upward separately (to simplify expansion).



Figure 16. EMT Review Session



Figure 17: EMT Review Session



Figure 18. EMT Review Session:  
Sharon Chimento and Peter  
Bonnadona discuss functional issues



Figure 19. EMT Review Session

## ERGONOMIC RESEARCH

Although I had done research into the weight limitations of humans, there was still a great deal more to investigate about the act of lifting and carrying, and the dynamics of a backpack. The human/machine interface needed to be clarified. The question of padding-how much and where the padding would be placed needed to be explored. Weight distribution also needed to be analyzed.

I began by researching current mountain pack technologies, reviewing several designs. Packing practice, as I discovered, assumed that the heaviest equipment should be as high as possible over the shoulders to bring the center of gravity further forward, thus reducing back strain. The disadvantage in this arrangement is the loss of agility. EMTs will have to adjust their loads to their own comfort level, and this will be facilitated by the modular design of the system. Modern packs are designed to be completely adjustable, based on a simple rectangular aluminum tube frame, with full adjustment of upper and lower cushions. Heavily padded straps disperse the weight evenly. A waist belt helps to put more of the weight on the hips.

For my concept for the ARS, I moved from the use of foamcore to appropriate aluminum tube construction. I revised the dynamic plan of the unit on the computer. This plan evolved as the design evolved. For testing, two padded sections were created, both adjustable. The hook pieces were devised. Analysis of the equipment list resulted in reorganization of the elements on the frame. Effective mountain packs were taller than my collapsible first mockup, so I eliminated the sliding wheel bracket in favor of a lengthened frame with a fold up shelf/wheel arrangement in an effort to simplify design. This was structurally sound and easier to operate than the earlier design.

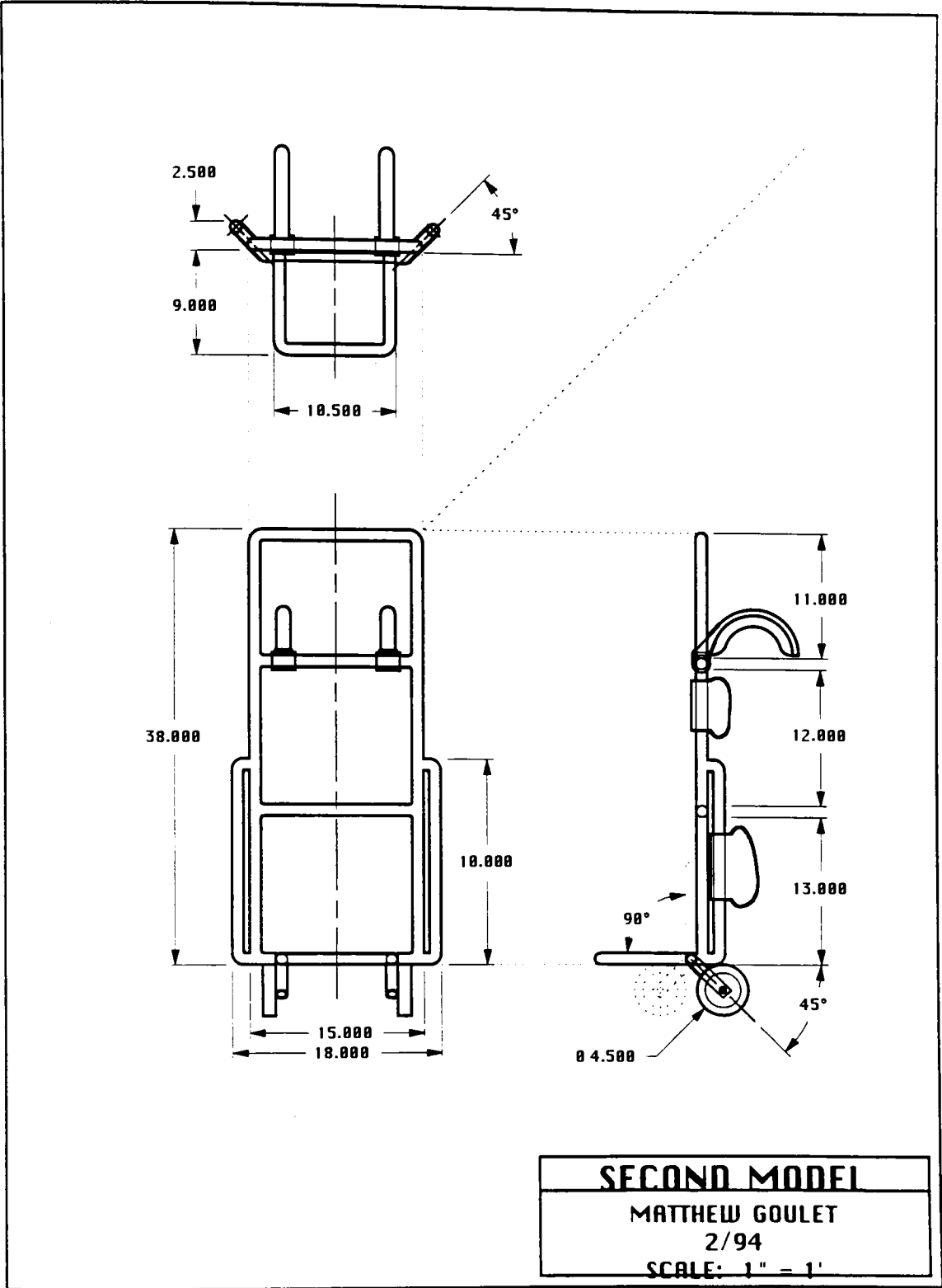

Figure 20. Preliminary Study of Second ARS Mock-up

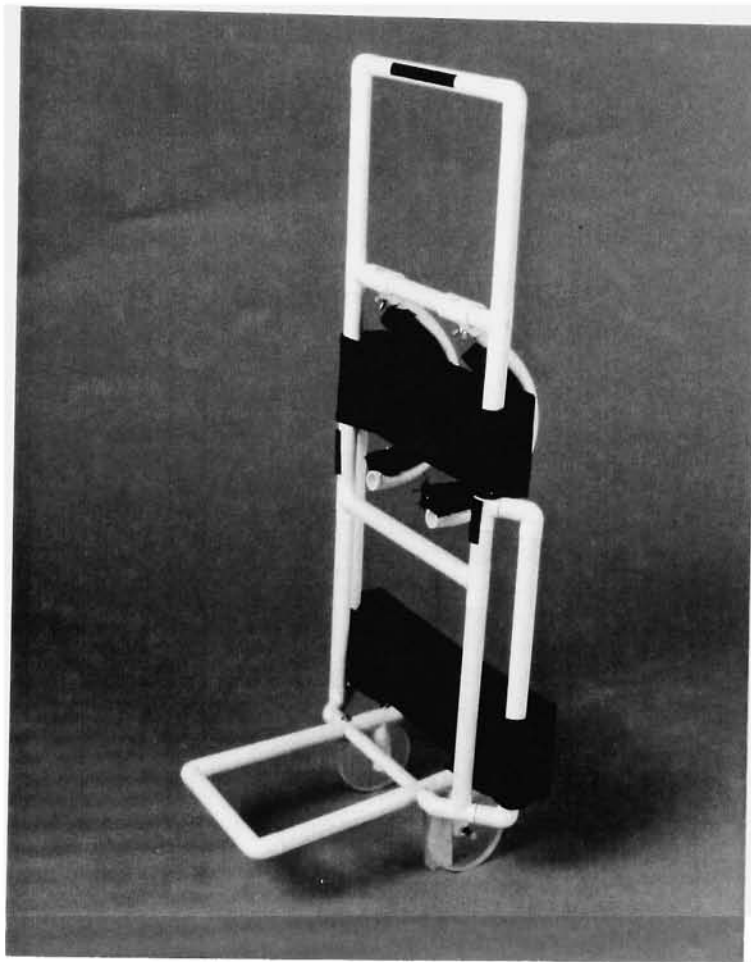

Figure 21: Second ARS Mock-up



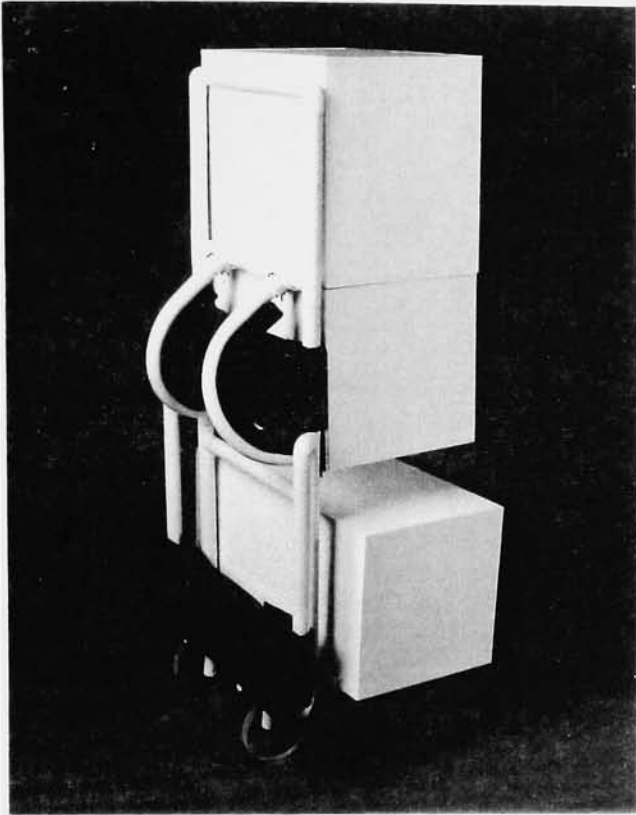

Figure 22. Second Mock-up of ARS with Drug Box (top), Trauma Bag (middle) and ILS (bottom).

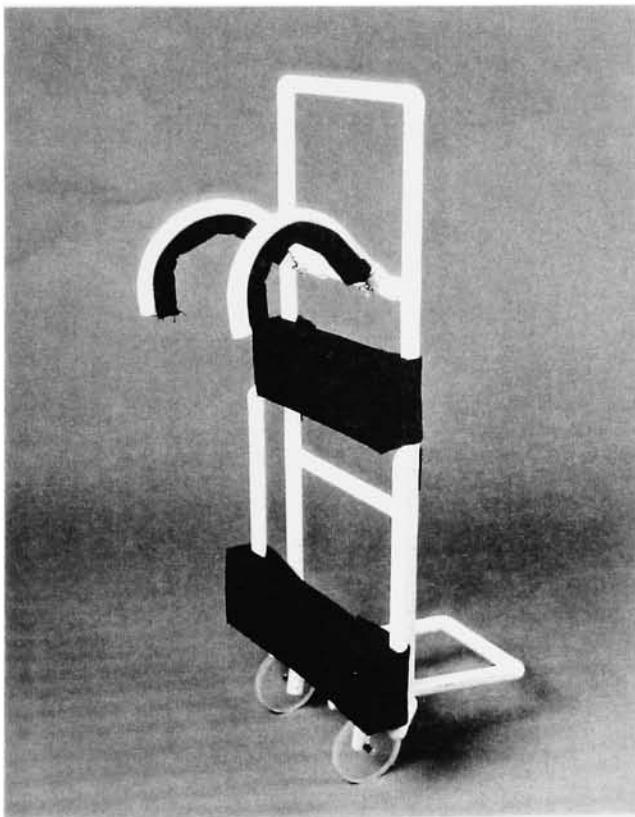

Figure 23. Second Mock-up of ARS with experimental hook design for backpack function.



Figure 24. Second Mock-up of ARS: Loaded in cart configuration.



Figure 25. Second Mock-up of ARS: Loaded in backpack configuration.

## THE MODEL

Putting the refined mockup into three dimensions allowed me to work out details that were difficult to visualize on a piece of paper. I used PVC tubing to form the basic frame. There are a few benefits to working in the PVC at this level in the design: PVC tubing comes with a variety of angle pieces, T connectors, and in many diameters. This provided a sturdy frame quickly, and allowed me to make quick changes midstream without much difficulty. I could put pieces together, and twist them into different positions, before adding the cement. It allowed me to experiment. PVC is consistent in shape and form and color. It is predictable when heat is applied, molding into different curves where necessary. Cushions were fabricated with foam and canvas bonded with hot glue. Cushions were secured to the frame using Velcro; this allowed for easy adjustment of cushion tension and position.

Once the mockup was complete, it was tested on numerous adults, and later on the EMT reviewers. The hook concept was evaluated as well as standard straps. Adjustment of the cushion position, form and size was noted. Proper head clearance was verified on all testers.

### THIRD MOCKUP: EMT & TESTING REFINEMENTS

At this point the second mockup showed promise -- it was functional and adaptable to manufacturing. Testing had provided additional input to its refinement. Still, the unit was too tall. It hung awkwardly down off the rear of the carrier, digging into the thighs of the wearer at times. When stood upright, the new wheel treatment made the unit unstable. Long deliberation resulted in ultimate rejection of the "hook" concept for the shoulders. Every tester's shoulders were different, so no ideal one-size-fits-all curve was comfortable for every wearer. Inevitably, these hooks would put pressure -- and a majority of the weight -- on the clavicle, or dig uncomfortably into the armpit region. Additionally, the hooks left the wearer feeling as if the pack might fall off, if the wearer leaned too far

forward. The beauty of the backpack strap became apparent: each strap conformed to the shape of any given shoulder, distributing the weight evenly.

The EMTs were excited by my developments in the second mockup. It was noted that the upper pad need not be variable, as the pack strap compensated. In order to simplify design, the wheels were finally mounted directly to the frame, providing better stability. The fold-down rack was changed so that it would operate separately from the wheels.

While the second mockup developed functional issues, I still had other issues to review. The design of the third mockup took the basic layout and isolated the aesthetic characteristics of a backpack, that had so influenced the form of the second mockup. This was a new product with a new identity. I wanted to explore adjustability. Also, the question of modularity had not been thoroughly explored. I wanted to see if I could further improve weight and mass reduction of the frame itself. Color had not been used thus far. Although the tube framing could have easily been used, I wanted to explore other possibilities. The carryall was to be carried on the back, but it would function as a cart more frequently. Connections between man and machine -- the switches, knob, and other controls -- needed to communicate their function in a new environment.

The final mockup took the functional principles of the second mockup and applied them to a form that would, I hoped, simplify its usage in a new environment. Derived directly from the dynamic layout of that second mockup, a new, refined form was developed.

The final form was a simplification of the rack principle. Instead of loosely and haphazardly strapping packages, a central spine -- an aluminum extrusion -- would support the equipment. Along this spine, many different attachments could be added for a customization of the load. This extrusion would also hold the strap, cushions, handles and wheels that make up the human interface. These, too, would be adjustable. The rail itself, made of aluminum alloy, would provide a firm but shock-absorbing undercarriage. Flat with inset grooves, the extrusion would provide low profile rigidity, and positive locking

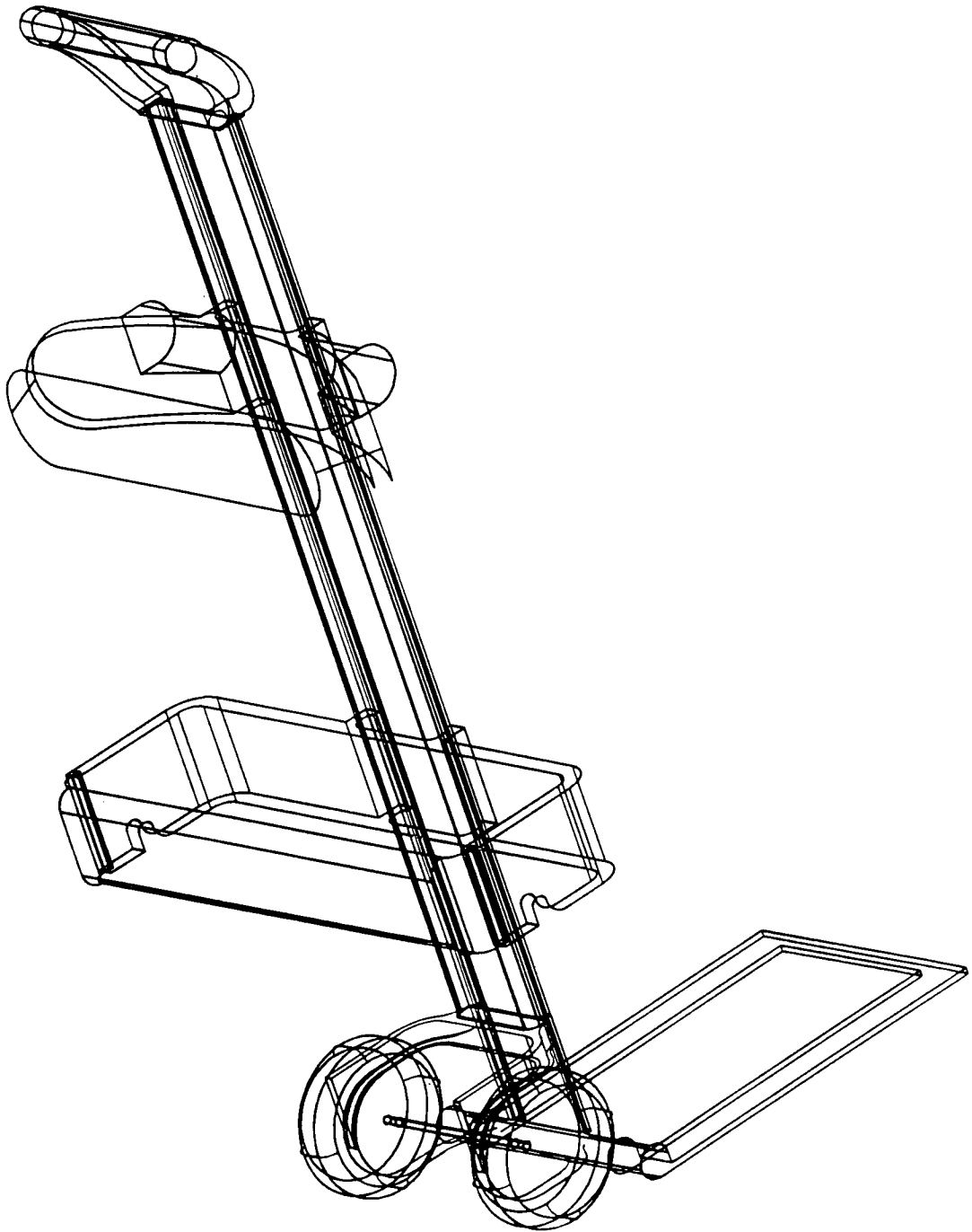

Figure 26. Wireframe of the Final ARS Design.

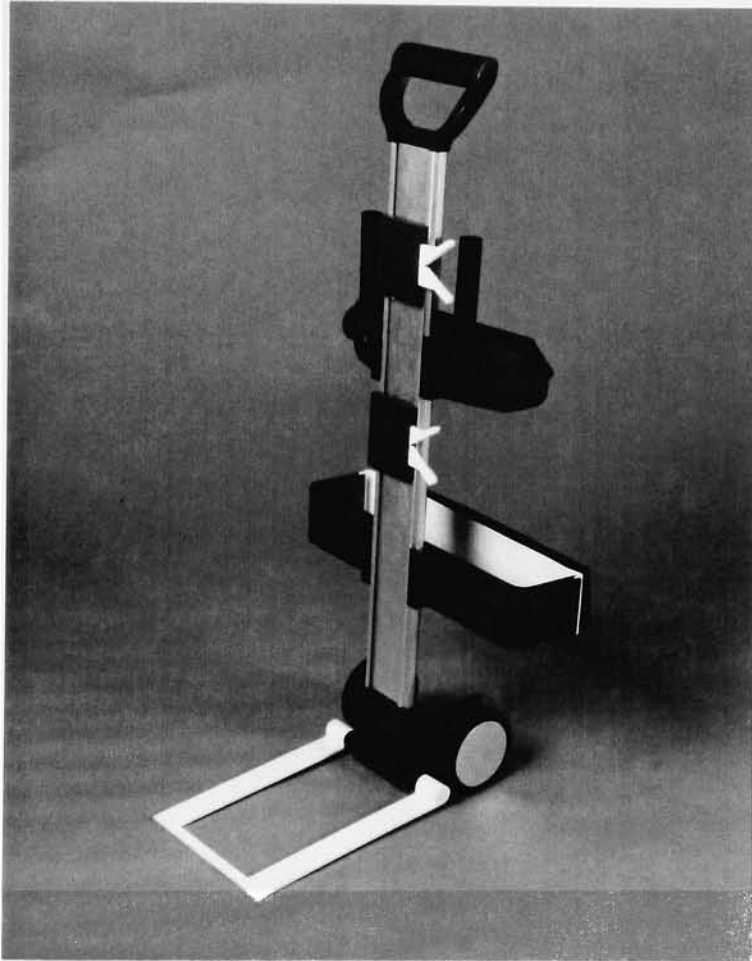

Figure 27. Final Appearance Mock-up of the ARS .





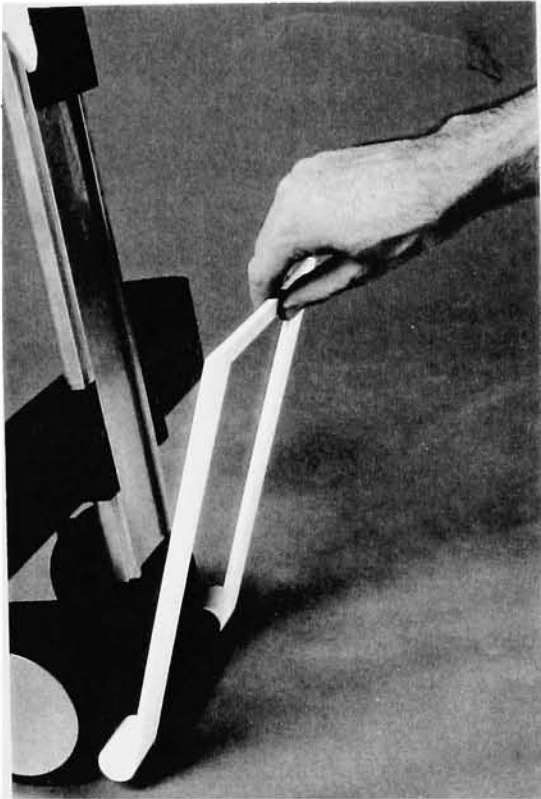

Figure 30. Lower shelf folds down to provide additional carrying capacity in cart configuration.



Figure 31. Mock-up Defibrillator being removed from storage

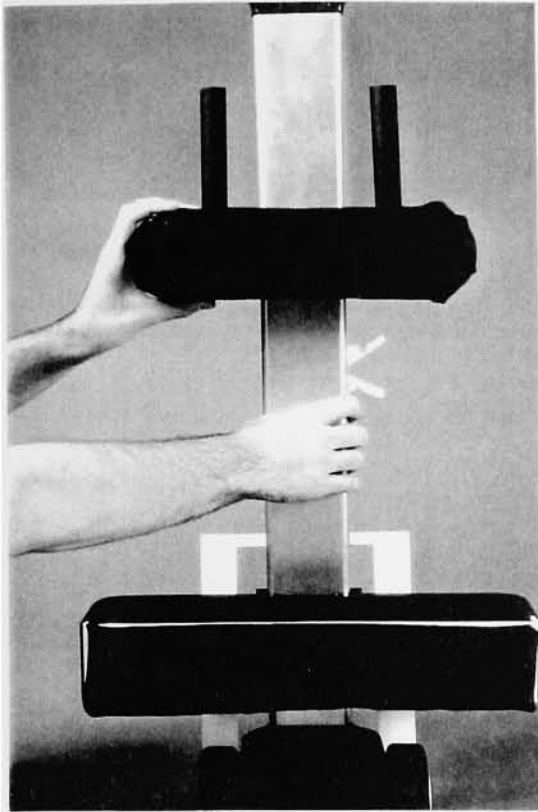
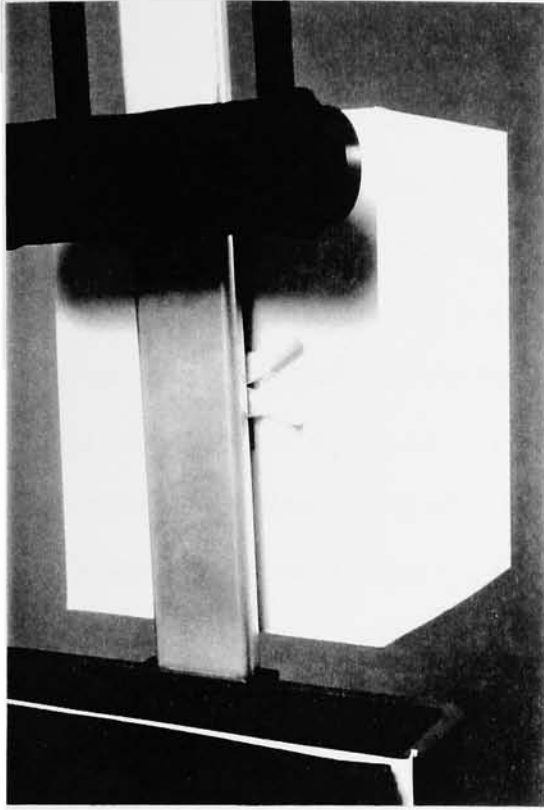

Figure 32. Fully adjustable padding



Figure 33. ARS in cart configuration



Figures 34 & 35. Equipment modules may be removed and added by compressing levers

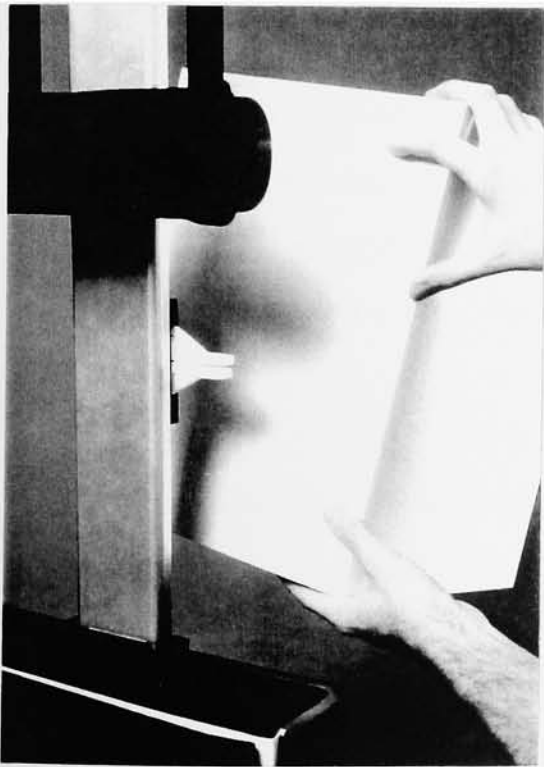

attachments. The top of the tube would be capped conveniently with a handle for use in cart mode. It would be carefully designed to provide a comfortable grip for either hand, without striking the back of the user's head when the frame is functioning as a pack. Two cushion units would be standard, fully adjustable, with straps built into the upper unit. These straps would be retractable, and lock into the lower support. The lower support would consist of a U-shaped bracket across which a soft cushion is stretched. Its function would be twofold. When the pack is worn on the back, the cushion would wrap around the lower waist of the wearer. When the unit is used as a cart, the cushion would stretch around the Defibrillator Unit to hold it in place on the inside face of the cart to protect it from impact. The wheel bracket at the base acts as a cap for the tube, providing a base for a defibrillator to rest when strapped in place. The fold-down shelf attaches to this base, and the axis of the wheels run through it as well. With these parts the primary functions of the cart can be performed.

A variety of clips could be added on the front face of the cart . This is where EMTs have the opportunity to customize their loads. Initially clips would be designed to anchor into the bottom of existing equipment, and then clip into the grooves of the rail. Additional clips could be designed to hold oxygen tanks, suction units, cellular phones, etc. Clips might be equipped with straps so that unusually-shaped items could be attached quickly. Finally, clips could be integrated into the design of new equipment -- i.e., drug boxes, ILS units, etc. This step would begin to modularize EMS equipment for the first time.

### FINAL MOCKUP CONSTRUCTION

The final mockup was meant to express the conceptual possibilities of the design. It was built primarily out of sheet and rod acrylic and Lexan and styrene, with some wood pieces, all painted with Enamel and Lacquer. It is primarily an appearance mockup, and as such does not address all of the mechanical issues necessary to take the product to production.

## PRESENTATION

This mockup was presented with a graphic presentation in the Graduate Thesis Show at the Bevier Gallery, Rochester Institute of Technology, in April of 1994 for evaluation by the faculty and students.

## FINAL NOTES

The ARS Adaptable Rescue System would require additional development before going into production. This thesis explored a need in the Emergency Medical Service for a storage/transportation device. By observing on an ambulance, I discovered the problem. By interviewing different Emergency Medical Technicians, I accumulated a list of issues and priorities that better defined that problem, resulting in a Product Statement. Research provided background information on existing equipment, the working environment, and safety issues. Analysis of this research supported the Product Statement with hard numbers, and lead to the development of several functional scenarios and link analysis narrowed the number of possible solutions. A volume study of the most feasible solution was created as the first step from research to concept. This study was reviewed by the Department of Industrial, Packaging, & Interior Design faculty, and then by a panel of experienced Emergency Medical Technicians. The concept was refined, based on their comments, and a functional ergonomic study was created. Testing of different options and additional review by the panel of EMT's led to a final appearance mock-up, which explored material selection, manufacturing, and a system of modular components. At this point, there are several interrelated marketing issues which need to be addressed.

The first issue is cost. How much is an ambulance company willing to pay for one of these units? The manufacturer will have to set a limit to the cost of production per unit based on the selling price. Once the form and function of the product have been determined, a variety of materials could be chosen for production. Every material has its

benefits and drawbacks within each manufacturing process. Lightness, strength, and durability will all be critical characteristics in this design.

To be successful, the manufacturer must decide how many units would be produced per year -- five thousand, twenty thousand, one hundred thousand, etc. This depends on the need. It may be determined that every EMT should have his or her own unit, or that each ambulance should be supplied with one. Different ambulance companies might have different requirements. The manufacturer should put out a limited run of pre-production testing units to send out to ambulance companies in different operating environment. I believe that this first design would be a modified version of the second study mock-up, because its functions with existing equipment. The overall cost of an ambulance company having to replace all of its drug boxes, trauma bags, etc. with modular versions would be prohibitive. Before going into volume-production, test units should be produced and sold at less than cost to a test market. There might only be 200 of these units, but they would provide important feedback. Once into production, this should grow to a steady production rate. Revised versions could eventually be released, incorporating a fully modular system of components, if the initial design was well received.

In the future, it would not be difficult to envision this product reaching a wider market, that of rescue work in general. Even in its present form, it could form the backbone of a storage system for firefighters, and other specialized rescue units.

This final mockup should not be interpreted as a working prototype. Development of better stability in rough terrain through the use of a wider wheelspan and larger wheels was suggested by faculty advisors, and the fold-down shelf would have to be designed to withstand more weight. Choice of materials will inevitably be a determining factor in the design of a final working prototype.

The Emergency Medical Service is clearly in need of design consultation -- much of its equipment is functional, but awkward. It is not surprising that aside from the psychological stress of working in crisis situations, Emergency Medical Technicians

commonly suffer from physical strain as well. This contributes to the high burnout rate associated with EMTs. The industrial design community should embrace this opportunity to improve working conditions for a group of people whose health and service are so important.

## SELECTED BIBIOGRAPHY

Arneson, D.J. *The EMT Handbook of Emergency Care*. Philadelphia: J.B. Lippincott, 1987.

Copass, Micheal K. *The Paramedic Handbook*. Philadelphia: Saunders, 1987.

National Safety Council. *Accident Facts*. Chicago: National Safety Council, 1993

New York (State). *Official Compilation of Codes and Regulations*. Albany: Department of State, 1960.

Salvendy, Gabriel. *Handbook of Human Factors*. New York: Wiley, 1987.

Woodson, Wesley E. *The Human Factors Design Handbook: Information and Guidelines for the Design of Systems, Facilities, Equipment, and Products for Human Use*. New York: McGraw-Hill, 1981.



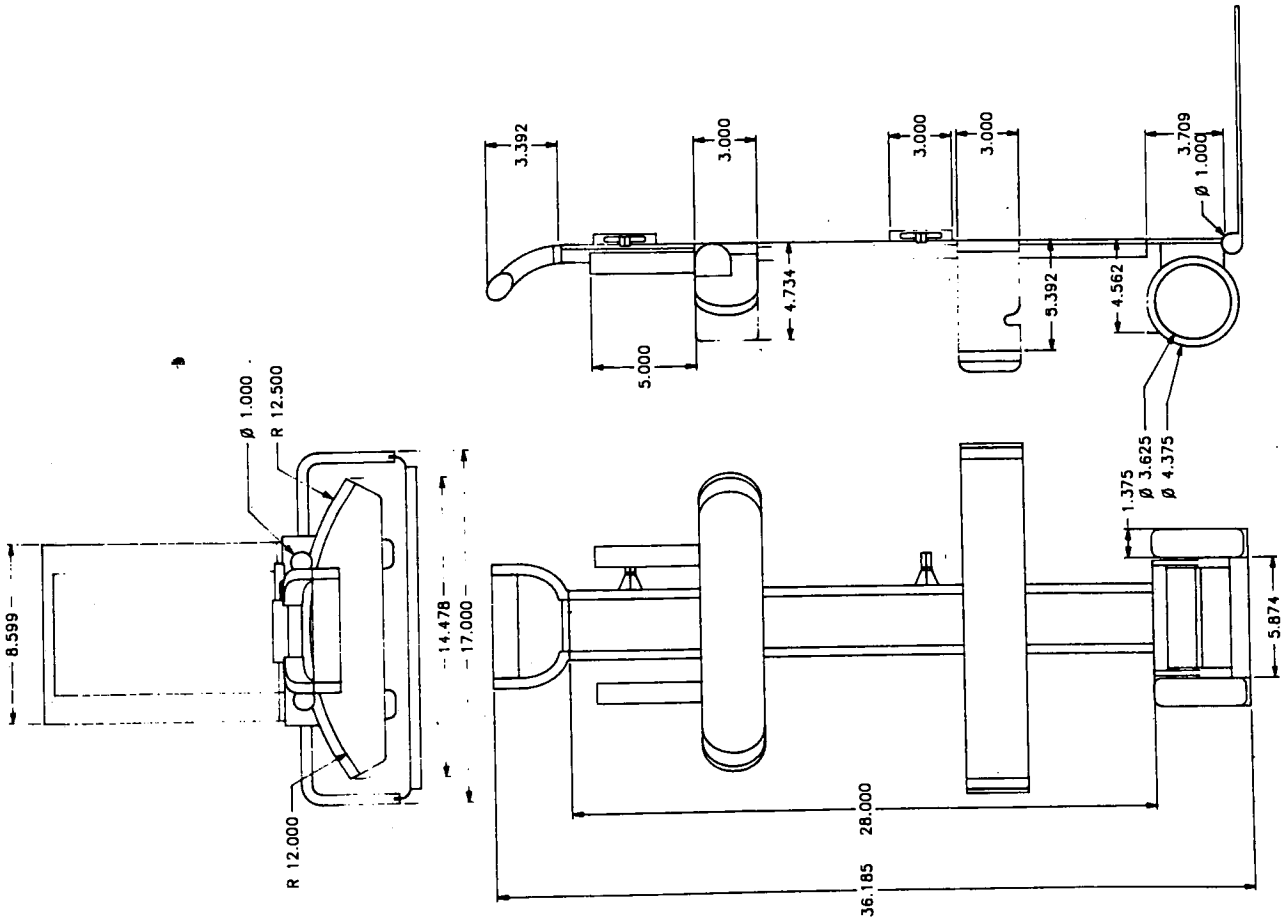
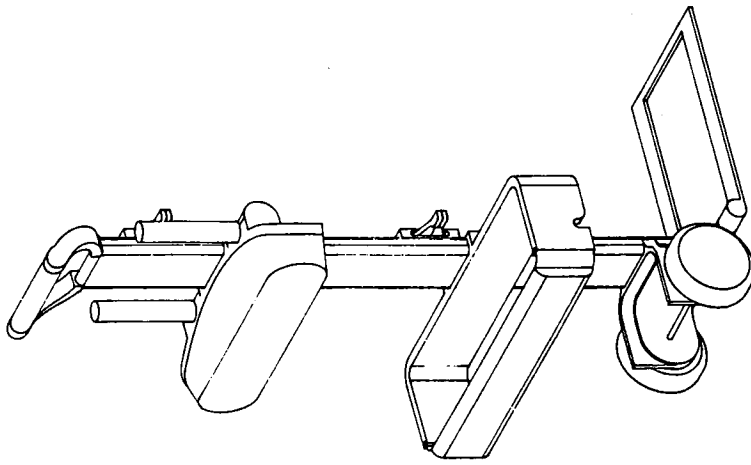

ARS-Adaptable Rescue System
MFA Thesis Project-R.I.T
Matthew Goulet
C 1/4"=1" SHEET 1 of 1
5/10/94