

**ROCHESTER INSTITUTE of TECHNOLOGY**

A Thesis Submitted to the Faculty of  
The College of Imaging Arts and Sciences  
in candidacy for the degree of  
Master of Fine Arts

**A Study of Human Office Support in the Office Environment**

By

Norman Horsch Fizz

February 14, 2001

## Approvals

**Chief Advisor:** Craig McArt

\_\_\_\_\_  
DATE: 3/14/01

**Associate Advisor:** Doug Cleminshaw

\_\_\_\_\_  
DATE: 01 mar 15

**Associate Advisor:** Kim Sherman

\_\_\_\_\_  
DATE: 3.14.01

**School Chairperson:** Nancy Ciolek

\_\_\_\_\_  
DATE: 3.15.01

I, Norman H. Fizz, hereby grant permission to the Wallace Memorial Library of The Rochester Institute of Technology to reproduce my thesis in whole or in part. Any reproduction will not be for commercial use or profit.

\_\_\_\_\_  
DATE: 14 FEB 2001

Copyright © by Norman H. Fizz

All rights reserved

# TABLE OF CONTENTS

LIST OF ILLUSTRATIONS .....	V
LIST OF TABLES .....	VII
ACKNOWLEDGMENTS .....	VIII
GLOSSARY .....	IX
CHAPTERS	
I. INTRODUCTION .....	1
II. RESEARCH .....	4
III. GOALS .....	16
IV. CRITERIA .....	20
V. DEVELOPMENT .....	26
VI. CONCLUSION .....	42
APPENDIX .....	45
BIBLIOGRAPHY .....	46

## LIST OF ILLUSTRATIONS

Figure	Page
1. Standing and Seated Man Spine Posture . . . . .	6
2. Relaxed Man Angle Measurements . . . . .	9
3. Recommended Seat Dimensions. . . . .	10
4. Serber's Ergomax® . . . . .	13
5. Aeron Chair . . . . .	13
6. Viennese Designed Sofa-Bed . . . . .	18
7. Upright . . . . .	20
8. Kneeling . . . . .	21
9. Reclining. . . . .	21
10. Fixed Armrest in All Three Positions . . . . .	22
11. Exploded View of Padding and Knockdown Construction . . . . .	24
12. Seat with Rocker . . . . .	27
13. Full-size Plywood "Shaker" Rocker . . . . .	28
14. Seat Motion Mapped to Paper . . . . .	28
15. Computer-Aided Design Rocking Seat Motion Map. . . . .	28
16. Track and Rail Mechanism. . . . .	29
17. Anthropometric Figure . . . . .	30

18.	Four-Bar Mechanism . . . . .	31
19.	Four-Bar Solution . . . . .	32
20.	Profiler . . . . .	33
21.	Profiler Combined with Four-Bar Solution in Reclined Position . . . . .	33
22.	Four-Bar Solution First Working Design. . . . .	34
23.	Seat, Back and Kneeler/Leg-rest Pin and Groove Paths. . . . .	35
24.	Side View of Mechanisms . . . . .	36
25.	Plywood Parts Cut Pattern. . . . .	37
26.	Tee-nut Plug Assemblage . . . . .	38
27.	Back Rest Mechanics and Fasteners. . . . .	39
28.	Thesis Chair Assembled in Task Position . . . . .	40
29.	Rocking Index. . . . .	41
30.	Chair in Show. . . . .	41
31.	Finished Prototype . . . . .	42

## LIST OF TABLES

Table	Page
1. Goals Defined by Category .....	16

## **ACKNOWLEDGMENTS**

First, I would like to thank the thesis committee Chairman Craig McArt for his constant patience, wisdom and guidance throughout the thesis process.

Special thanks, as well, to committee members Kim Sherman and Doug Cleminshaw for their motivation through insightful questions and comments.

I would like to express appreciation to Richard Negus for being the extra two hands needed to finish the prototype throughout the night and early morning and Stephen Schaeffer, Astrida Schaeffer and Carl Nickerson for their erudite understanding and assistance with the written word and mental support.

Finally, I would like to thank my parents Sieglinde Field and Grant Fizz III for their never ending support.



## GLOSSARY

Ischial: Pertaining to the lowest part of the hip bone, on which the body rests when sitting.

Ischemia: The restriction of blood flow in the body from an outside pressure.

Necrosis: The decay or death in body tissue.

Seatpan: The part of a chair which supports the hip and upper thigh.

Waterfall: The front part of the *seatpan* where the seat material curves or rolls away from the area of the thigh behind the knee.

# CHAPTER I

## INTRODUCTION

This thesis is about seating, the problems it creates, and a solution to those problems. This chapter will provide an overview of our bodies, a look at our work and an analysis of the problems created. It will explain my idea for a solution and describe how that solution was achieved. The chapters which follow go into further detail about the material presented.

## PREMISE

Human anatomy has not changed much for thousands of years. Muscles, bones, back, digestive tract, and physiology are the same as that in place when we were a nomadic culture. During the past several thousand years, our society and culture evolved dramatically from a highly mobile society to a sedentary one. An imbalance has emerged between our bodies and our workplaces. As Western culture proceeded toward a service based economy, the number of jobs requiring lengthy seated positions at a desk increased. The change has created problems for our bodies and lifestyle.

## PROBLEM

Sitting for long periods of time is contrary to our physiological need to move. This has resulted in stress on the body, affecting eating, moods, and daily activity, in some cases lowering the quality of life and increasing health risks.

## **Types/Examples**

Discrepancies between our body's physiology and the increased seated time demanded by our society have led to back problems, reduced blood circulation, muscle fatigue, and skin anesthesia. Back problems range from muscle strain to disc injuries such as disc herniation. Reduced blood flow causes numbness and tingling, particularly in the buttocks and thighs. Muscle fatigue results from a set of muscles working constantly to retain a position for an extended time, much like holding one's arm out straight for a minute or so. Skin anesthesia comes from maintaining a seated position on soft seats for prolonged periods of time. These individual problems lead to social problems which will be explained in more detail later in chapter 2.

## **OBJECTIVE/HYPOTHESIS**

More body movement and stimulation in the workplace would assist in solving the problem. A seat could be designed that promotes activity rather than restricts it. Such a seat would provide the worker with body support to facilitate the work while minimizing fatigue.

## **HOW**

The solution involves researching the problem, setting standards, defining the specifics for a solution, and creating that solution. Chapter 2 presents a report on my research. It details the subject matter introduced in this chapter. It includes a definition of the extent of the problem, a proposal for ergonomic and

anthropometric recommendations, and a presentation of other solutions. Chapter 3 outlines and organizes the major goals to be attained. The needs of the user shapes those objectives. The criteria chapter 4 sets specifics such as dimensions, shape, etc., defining what is necessary to attain the goals listed in chapter 3. Chapter 5 explains the process used to design, develop, and create a functioning prototype seat. This seat displays what is necessary to diminish harm caused by being sedentary, and by doing so, it enhances quality of life.

## CHAPTER II

### RESEARCH

This chapter reports on the research undertaken. It details the subject matter introduced in the first chapter, including ergonomic guidelines, the extent of the problem, and recommendations.

### SEATING PROBLEMS

#### **What are the negative effects associated with sitting?**

Prolonged sitting creates a variety of physiological problems. Since the largest and most costly seating problems relate to the human back, they serve as the focus for this thesis.<sup>1</sup>

Evidence shows prolonged sitting can cause complications ranging from simple pain to serious health issues. Pain can be a signal of future health concerns. For example, "An Epidemiological Study of Acute Herniated Lumbar Intervertebral Discs" found that "men who spend more than 1/2 of the workday in a car have a 3 fold increase in disc herniation."<sup>2</sup> Lower back problems are second to heart conditions as causes for hospital visitation, are the fifth-ranking reason for hospitalization, and are the third-ranking reason for surgical procedures.<sup>3</sup>

These complications, if not affecting a person directly, impact us as a group

---

1. *Occupational Low Back Pain: Assessment, Treatment, and Prevention*. (St. Louis: Mosby Year Book, 1991), 251.

2. Kelsey, J.L., "An Epidemiological Study of Acute Herniated Lumbar Intervertebral Discs," *Rheum Rehab* v14 (1975): 144.

3. *Occupational Low Back Pain: Assessment, Treatment, and Prevention*, 97.

through shared costs, like group insurance rates. Back pain, especially in the lumbar region, causes a great deal of absenteeism in the work place, and a resulting loss of productivity.<sup>4</sup> The total costs to government and industry are staggering. The United States government spends billions through programs such as Medicare and Social Security Disability for lower back pain alone. The cost to industry can be around \$40 billion in a year, and is not a recent problem as we see in J. Antonakes article “Claims Costs Of Back Pain,” to the effect that in “1980 Liberty Mutual paid \$217 million for compensating lower back pain, almost \$1 million each working day.”<sup>5</sup> We share these costs through social security deductions at work, through taxes, through higher insurance rates, and through higher prices for goods and services provided by industry.

The current solutions for prolonged sitting problems at work are not the best suited for humans. This creates an economic burden for the employer and the country, and possible health risks for the employees.

### **Why are there sitting problems?**

Several factors lead to the causes and costs of back pain. This section focuses on the clash between our physiology and social culture.

Our bodies have not changed significantly since our nomadic ancestors walked around in search of food. Our genes and the genes of chimpanzees differ by less than one percent. The difference, genetically, between ourselves and our ancestors, walking the earth 100,000 years ago, is near none.<sup>6</sup> The body is a

---

4. Ibid., 95.

5. Ibid., 106.

6. Sears, Barry. *Enter the Zone*. (New York, New York: Regan Books/Harper Collins, 1997), 100.

nomadic design, meant to travel by foot, and to move throughout the day.

Our culture is different now, and the daily environment involves inactivity. If we think about our workday, most of us would remember spending it sitting or being confined to a limited space. The reason we sit still is due in part to the adoption of an erect posture theorem philosophy<sup>7</sup> and in part to a focus on the work task, not on the worker. These attitudes, called Taylorism,<sup>8</sup> were initiated in the 1800's. Not until recent times has this paradigm been challenged.<sup>9</sup>

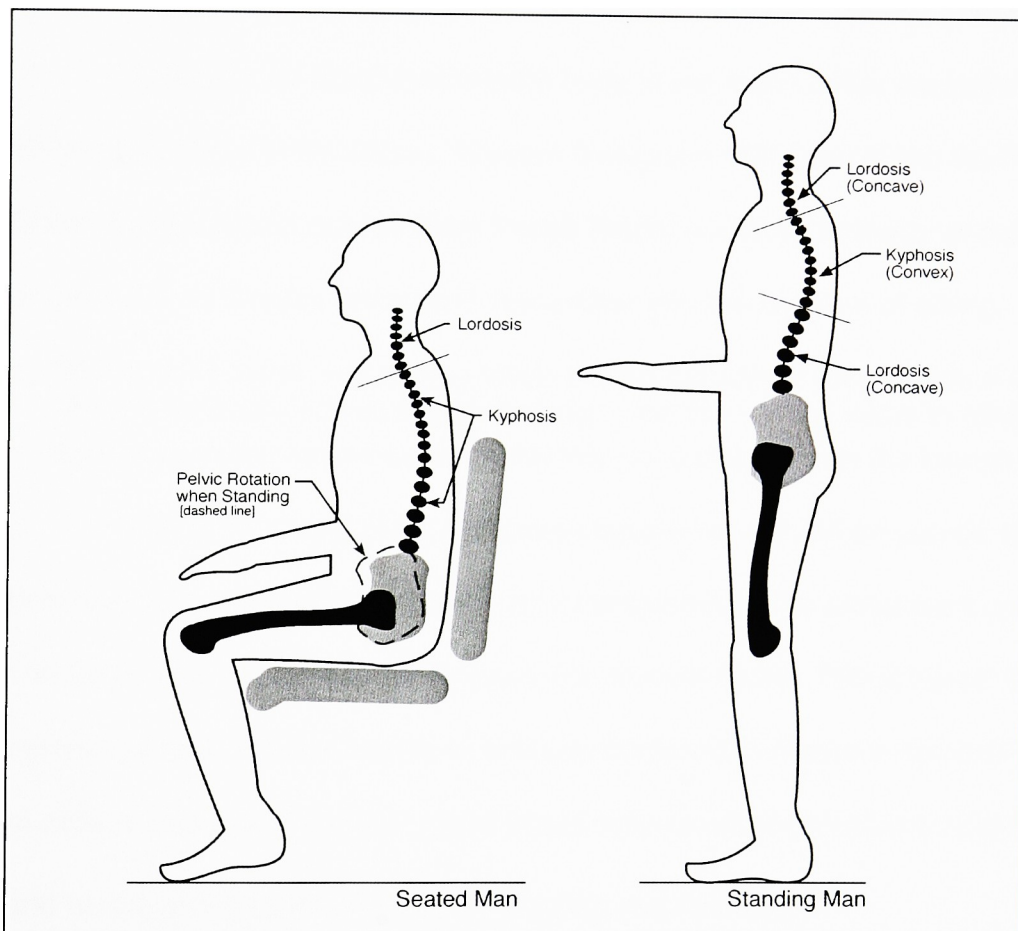

Figure 1. Standing and Seated Man Spine Posture

7. Taylor, Mark, "In Search of an Ideal Seated Posture," *Workplace Ergonomics* July/August (1996):11.

8. Knobel, Lance, *Office Furniture* (New York, NY: E.P. Dutton, 1987), 8.

9. Taylor, Mark, "In Search of an Ideal Seated Posture," 11.

We think of sitting as a relaxed position, but it takes a lot of work for our body to hold itself up. Here are a few things occurring to one's body while seated:

- To stand or sit erect is a complex balancing act (see Figure 1).

“Almost 100 muscles are required to assist a seated worker in maintaining balance. This is because the spine supports the worker's upper body. The spine is flexible to allow movement, but it is this very flexibility that makes it ill-suited for support. If the spine is not supported, there is a natural tendency to lean forward. This position is known as lumbar kyphosis. As the body leans forward, more tension is placed on the support muscles. This can result in fatigue, headaches, and backaches. In addition the bones of the spine (vertebrae) contain no nerves, so the pain resulting from improper seating is not felt until the delicate discs between the vertebrae have become worn.”<sup>10</sup>

- Sitting in the most comfortable chair is not much better because it is stagnant seating. In his article, “Modern Designers Still Can't Make the Perfect Chair,” Doug Stewart quotes Mary Plumb Blade, a retired professor of mechanical engineering at Cooper Union and researcher into the problem of sitting.

“If you don't move, you quickly begin to lose calcium in your bones. A chair that fits you perfectly is probably damaging.... the form-fitting seats in NASA's first space capsules turned out to be terribly uncomfortable on the launch pad.”<sup>11</sup>

- Sitting for long periods can cause trouble as well. When you sit, the tissue between the bone and seat surface gets compressed. The blood can't get to the soft tissue overlying the bone because the vessels flatten. This is called *ischemia*, meaning a lack of blood supply to a tissue. Ischemia can cause *necrosis* or death of cells or tissues. The compressed tissue may result in pressure on the nerves and blood vessels with consequent tingling and numbness.<sup>12</sup>

---

10. Metzger, Edward A. “The Importance of Lumbar Support,” *Workplace Ergonomics* July/August (1996):14.

11. Stewart, Doug, “Modern Designers Still Can't Make the Perfect Chair,” *Smithsonian* v17 (April 1986):104.

12. Berg, Joseph A., *Posture and the Sedentary Man* (San Francisco, CA: A.C.C.O. Convention, 18-19 May 1968), 7.



- Bending your upper leg relative to the torso rotates the pelvic bone, which changes the curve of the lower spine (see Figure 1).<sup>13</sup> A good example of this change is shown by slumping forward. The change can be felt as the lower back moves to the convex position. This posture is the incorrect way to pick up objects off the floor, and is a cause of back injuries as it tends to pinch or squeeze the intervertebral discs. If these discs herniate, they can press against the nerves, resulting in sciatica.

## **ERGONOMIC RECOMMENDATIONS**

Ergonomics engineers study and attempt to understand the body and how it relates to the world. Some studies provide guidelines and suggest solutions for the seating dilemma.

### **Anthropometrics**

This aspect of ergonomics is about the measurement of man, or anthropometrics, as it relates to seating and rest.

The human spine flexibly supports the upper body. In doing this there is an optimal shape for it to work properly, a double S-curve. Looking at the body from the side, the shape of the spine from the base of the skull to the upper ribcage is concave, called lordosis. The thoracic portion is convex, called kyphosis. The lumbar region, or small of the back, returns to the lordotic posture (see Figure 1).

Poor posture is shown as “Seated Man” in figure 1. The lumbar area is no longer concave. It reverses shape into kyphosis. This results from the rotation of

---

13. Ibid, 5.

the pelvic bone caused by sitting. It actually slumps the back.<sup>14</sup> One can feel the difference in posture by standing up and sitting down.

### Relaxed Man

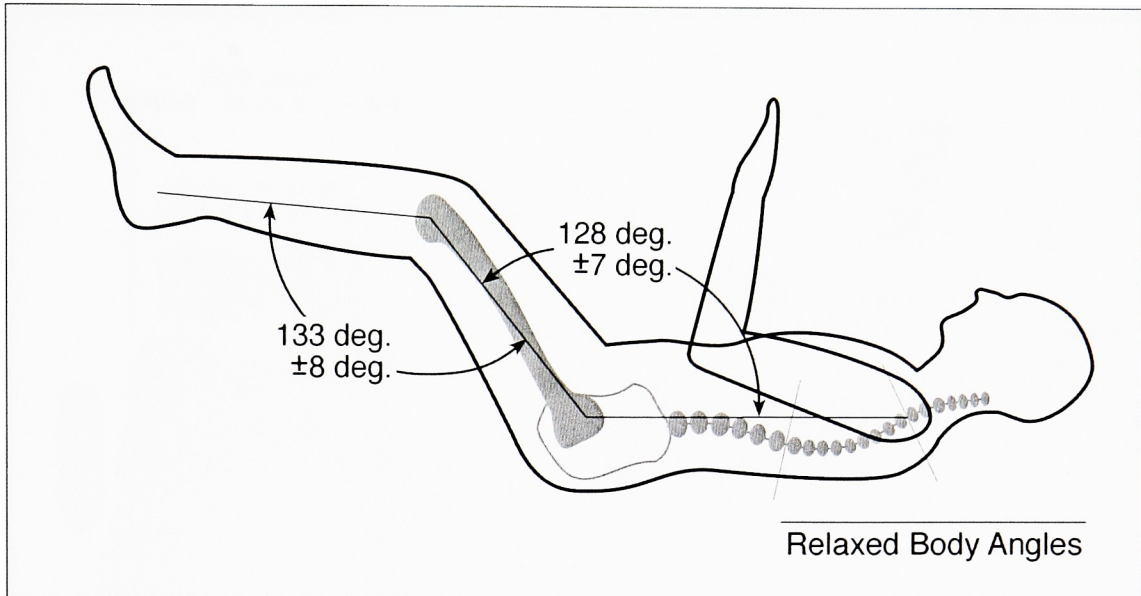

Figure 2. Relaxed Man Angle Measurements

Figure 2 shows some angle measurements from a study on relaxed men in space at zero gravity.<sup>15</sup> The angles shown are considered to be the natural resting place where the muscles in the legs and back are equalized. Notice that the legs are not 90 degrees to the body. The pelvic bone has not rotated and the lumbar curve is still lordotic.

### **Seating Standards**

Recommended dimensions for task seating are shown in figure 3. This information was compiled from *Human Dimensions And Interior Space* by Julius

14. Ibid.

15. Sanders, Mark S. and Ernest J. McCormick (Ernest James), *Human Factors in Engineering and Design* (New York: McGraw-Hill, 1987), 509.

Panero and Martin Zelnik<sup>16</sup> and the recommended dimensions for VDT operators from AT&T Bell Laboratories.<sup>17</sup> The prescribed standards are divided into three parts: seat, armrests and backrest.

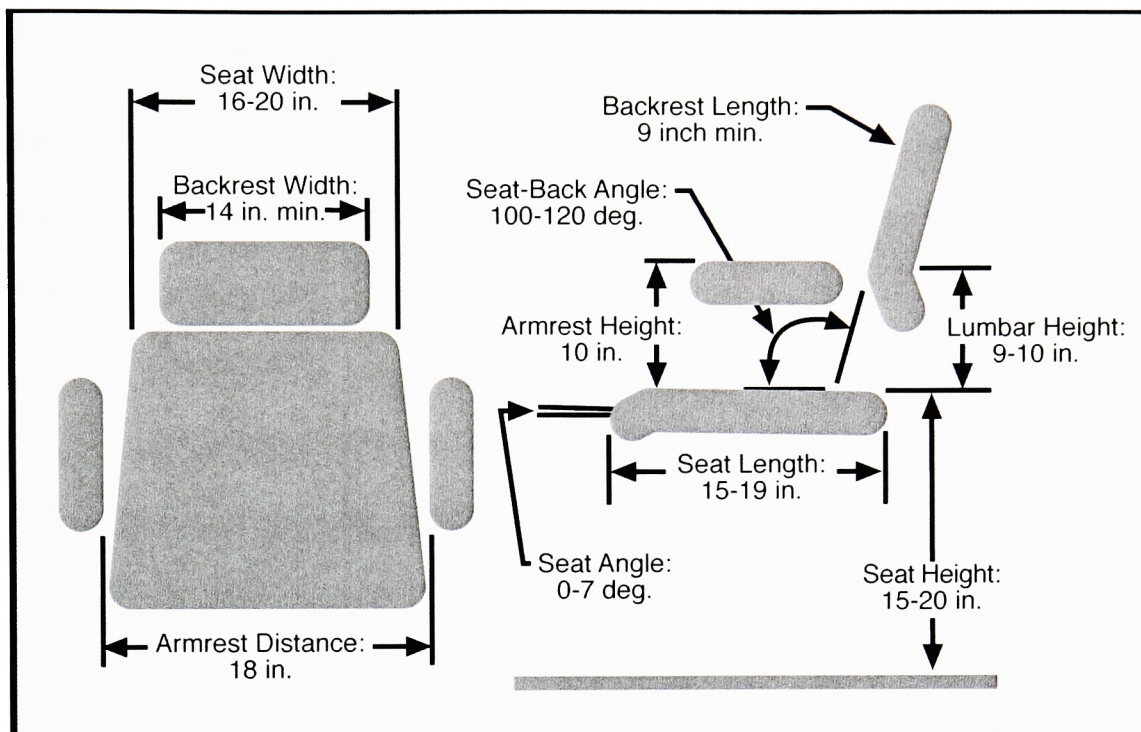

Figure 3. Recommended Seat Dimensions

### Seat

The seat (sometimes referred to as *seatpan*) needs a minimum width of 16 inches and a length of 15 to 19 inches, with a rollover (sometimes referred to as *waterfall*) on the front edge. This rollover under the knee joint prevents pain and circulation loss which results from pressure. Seat height above the floor is an adjustable 15 to 20 inches. The seatpan angle with respect to the floor is between 0 and 7 degrees.

16. Panero, Julius and Martin Zelnik. *Human Dimensions and Interior Space*. (New York: Billboard Publications, 1979), 175-179.

17. *Ibid* 354.

### **Armrests**

Armrests should be 10 inches above the seat and have a minimum distance of 18 inches apart.

### **Backrest**

A protrusion in the back rest 9 to 10 inches from the seat will restore a concave shape (lordosis) in the spine.<sup>18</sup> The back angle ranges from 100° to 120°, relative to the seat. Back support length is a minimum of 9 inches and width is a minimum of 14 inches.

### **Recommendations**

Professionals at Steelcase, an office furniture manufacturer, suggest a wide range of solutions for problems of prolonged sitting. For instance, while sitting, arms need free movement. If the seat back is too broad, it will block arm rotation. People have many sizes and shapes. The chair needs to accommodate a variety of users, and a solution to this is to make the chair adjustable.<sup>19</sup>

### **Moving**

As stated before, the body is developed for movement. Prolonged static seated positions can cause pain.<sup>20</sup> Dr. Joseph Berg, in a paper on *Posture And The Sedentary Man*, affirmed that changing seating posture is very important to delay muscle fatigue.<sup>21</sup> Therefore, any form of body support in the workplace needs to either provide for changes in position or provide for motion.

---

18. Ibid, 350.

19. "Adjustability's Untapped Potential," *Workplace Ergonomics* May/June (1996):11.

20. *Occupational Low Back Pain: Assessment, Treatment, and Prevention*, 20.

21. Berg, Joseph, A., *Posture and the Sedentary Man*, 7.

## Rocking

Researcher Mary Plumb Blade, cited in “Modern Designers Still Can't Make the Perfect Chair” by Doug Stewart, recommends rocking as a one of the two best solutions for the problems associated with sitting.<sup>22</sup> This motion creates both exercise and a calming effect. It provides a greater range of movement, the previously suggested solution.

One study by Janice Pikna, using a fixed arm rocker, finds rocking benefits elderly women by providing a form of exercise. Encouragement of exercise in this manner enhances the quality of life and decreases possible health costs.<sup>23</sup>

The motion of rocking produces a calming effect. Bernice Steinbaum writes in her book *The Rocker: An American Design Tradition*:

“It would be wrong of us to look upon the rocker with nostalgia as simply a piece of Americana, for it continues to fulfill needs today. There’s even a Boston doctor who prescribes rockers for patients as an important part of convalescence”.<sup>24</sup>

Another example appears in Richard Knox’s article, “Rock of Aged: Chair's Sway May Soothe Ailing Elders,” where he quotes from the study, *Rocking Chair Therapy For Nursing Home Residents With Dementia*, presented at the Eastern Nursing Research Society in Rochester, N.Y., by Nancy Watson, who states that “rocking for at least an hour and 10 minutes a day eases depression and anxiety among elders suffering from Alzheimer's disease.”<sup>25</sup>

---

22. Stewart, Doug, “Modern Designers,” 104.

23. Pikna, Janice Kuiper, “The Acute Circulatory Responses of Elderly Women To Upper and/or Lower Extremity Exercise In a Specially Designed Rocking Chair” (MS in Nursing, University of Wisconsin, Milwaukee, December 1986):77.

24. Steinbaum, Bernice, *The Rocker: An American Design Tradition*, (New York: Rizzoli, 1992),10.

25. Knox, Richard A., “Rock of Aged: Chair's Sway May Soothe Ailing Elders,” *Boston Sunday Globe* April 26 (1998):A24.

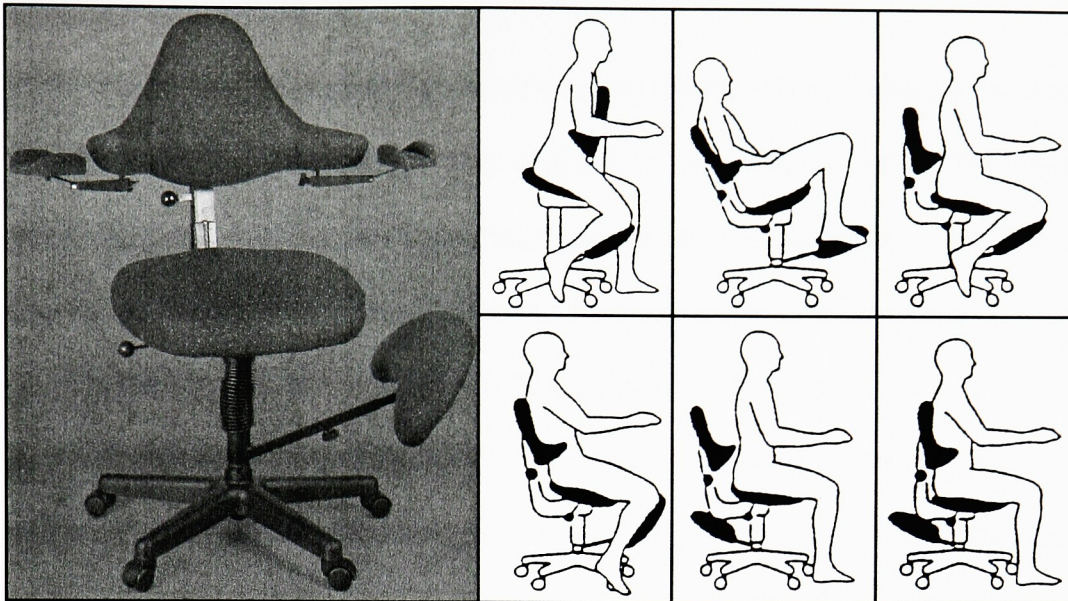

Figure 4. Serber's Ergomax®. *Left*, chair; *right*, example positions. [Reprinted, by permission, from Arlyn Serber, "American Ergonomics: Press Info," chair, as reproduced in <http://www.americanergonomics.com/press/ergomax.sit>; internet; Fri, 29 Sept 2000. and "Fig 6 ISOSPS - Integrated System of Postural Support," positions, as reproduced in *Ergomax CB and ISOPS: A New Paradigm for the Biomechanics of Ergonomic Seating*. (a pamphlet from American Ergonomics Corporation, Novato, CA).]

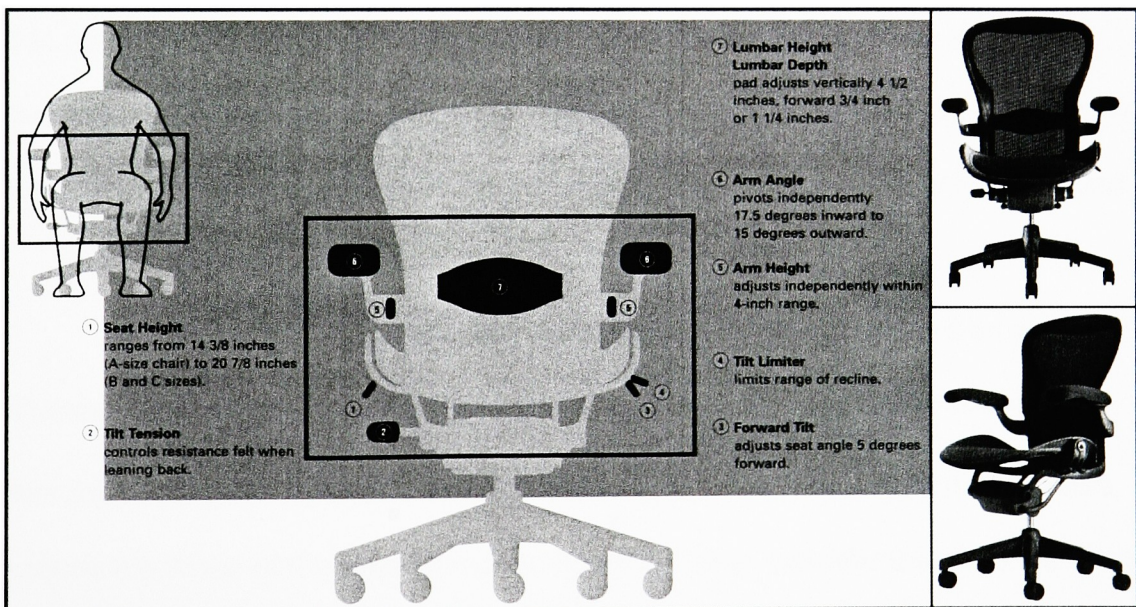

Figure 5. Aeron Chair. *Left*, diagram of 7 knobs for adjustment; *right*, chair front and corner. [Reprinted, by permission, from Lee Sullivan, diagram on page 8 and chairs on page 23, as reproduced in *Wear It in Good Health The Aeron™ Chair by Herman Miller*. (a catalog from Herman Miller Inc, Zeeland, MI: USA, 1994).]

## OTHER SOLUTIONS

Many chairs designed today attempt to resolve back problems by other means than just pushing the lumbar region into the correct position. The solutions range from extremely mechanical back support devices capable of multiple seating positions to tilt-forward seats and mobile office arrangements.

### **Mechanical Back and Multiple Body Position Support**

There are a great number of mechanical monstrosities of varying complexity available to the consumer. They all try to find a perfect position of support for the body. The most extreme models are listed here. The most mechanical multiposture body support is Serber's Ergomax 1700® (see Figure 4).<sup>26</sup> The operation of this chair is complex enough to require a VHS video explaining the use of the device's stool, traditional, forward leaning, kneeling, kneeling with back support, and reclining positions. Another chair that falls into this category is the popular Aeron Chair, which has seven separate knobs and levers to adjust posture (see Figure 5). To ease user confusion an eight page how-to booklet, one page diagram and multi-media compact computer disk is provided.

### **Balans Chairs**

The Balans Chairs, which use a simpler approach, are described as "U-shaped, backless rocking stools in which the sitter half sits and half kneels, thereby forcing the spine into a healthful posture."<sup>27</sup> The leg angles these chairs require are those of the relaxed man in figure 3. Some consider this chair the best

---

26. Null, Roberta L., *Universal Design: Creative Solutions for ADA Compliance* (Belmont, California: Professional Publications, 1996), 157.

27. Stewart, Doug, "Modern Designers," 102.

solution to date for providing the natural lumbar shape of lordosis. As the article “The Balans Chair and its Semi-Kneeling Position: An Ergonomic Comparison With Conventional Sitting Position” in the publication *Spine* relates, “Studies of the so-called Balans Chair, which induces sitting in a semikneeling posture, show that this posture actually results in increased muscle activity of lumbar and cervical muscles and increased blood flow to the feet compared to a standard chair.”<sup>28</sup> Doug Stewart in his article “Modern Designers Still Can't Make the Perfect Chair” notes “when I spend a day in one, my shins soon ached. Whenever I leaned forward to talk on the phone, my feet fell asleep. And fidgeting was nearly impossible.”<sup>29</sup>

### **Office Landscaping**

In the mid-1950s the theories and application of office design started to change. European designers developed Burolandschaft (office landscaping) which shifted focus away from a grid-like arrangement of desks, toward an open layout which followed the movement of paper and the flow of tasks.<sup>30</sup> American designers George Nelson and Robert Propst jointly developed Action Office for Herman Miller. This system of furniture advocated changing postures with different tasks.<sup>31</sup> These changes in philosophy started a reversal of Taylorism, refuting its sedentary work space ideology, and increasing mobility of an employee’s tasks.

---

28. *Occupational Low Back Pain: Assessment, Treatment, and Prevention* (St. Louis: Mosby Year Book, 1991), 27.

29. Stewart, “Modern Designers,” 102.

30. Knobel, *Office Furniture*, 59-61.

31. *Ibid.*, 74-76.



## CHAPTER III

### GOALS

Table 1 lists, defines, and categorizes the objectives developed from the previous research. They are presented in order of priority.

Table 1. Goals Defined by Category

Categories	Goals	Creates
Positions	moving	increased circulation and reduced muscle fatigue
	task	desk access
	kneeling	lumbar lordosis with desk access
	relaxing	increased circulation and reduced stress
	rolling	travel in work environment
Size	compact	working within confined spaces
	universal	for a wide range of users
Interface	intuitive	understandable operation
	simple	fewer instructions
	transparent	ease of adjustment
Visual	dynamic	
	warm	welcoming, inviting, and playful look
	fun	appearance
	exciting	
Construction	style	Viennese sofa-bed
	minimal	easy assembly and knockdown
	modular	interchangeable and customizable seating

### POSITIONS

The body support should permit the user to sit, kneel, rock, recline, and roll. Drawing on the research, it is clear that rocking creates movement which benefits the body. It is highly recommended as a way to reduce muscle fatigue and increase circulation. Sitting in a normal task position allows the user to access the desk surface and related work, such as computing. Because it is the most

common position, it is the most understood by ergonomics engineers and accepted by users. Kneeling in the Balans position grants the same desk access with the benefit of opening the angle between the back and thigh, thus providing lumbar lordosis. Reclining also assists with opening the same angle, encouraging circulation and relaxation. Periodic shifting between the two positions clearly encourages body movement and reduction of muscular fatigue, which is necessary. The inclusion of rolling assists the operator with moving within the work environment.

## **SIZE**

The chair needs to interact with the under-portion of a desk and fit in small office spaces. Designing the chair to be compact will fit more limited space requirements. Making the chair able to accommodate large and small people provides proper support for a wide range of users.

## **INTERFACE**

The user interface should have intuitive operation, require as little instruction as possible, and be transparent. Intuitive operation in that the interface follows the logic of the action, so the user can easily grasp the action required to adjust a position. For example, to move the back forward, pull up on the back; to lower it, push it down. This simplifies the amount of written directions and reduces possible user confusion. Transparent, in this case, means that the user does not have to explicitly adjust everything. Some adjustments are then automatic, and

not something with which the user has to interact.

## VISUAL

It is desirable that the chair look warm, playful, and exciting to make it attractive to potential users. The visual logic or semantics should suggest that it moves. An example of this style is a Viennese designed sofa-bed (see Figure 6).



Figure 6. Viennese Designed Sofa-Bed

[Reprinted, by permission, from Adolf Krischanitz, "One-Shaped Couch," furniture, as reproduced in *Wien Möbel* (Vienna Furniture). (Vienna, Austria: Die Secession, 1989), 43.]

## CONSTRUCTION

Construction of the sections - seat, back, feet, and armrests - should be simple for the end user. A simple, modular design naturally points to a knockdown type of construction, with the ability to assemble, disassemble and reassemble a product. Knockdown assembly requires interchangeable parts, and is, thus, both

simple enough that the owner could replace a section, and easy enough to construct, package, and ship for the factory.

Modular design implies that the chair could be customized by simply changing one part for another, modified one. For example, a user who has scoliosis and requires personalized back padding could change the back sections instead of having a special chair made.

## CHAPTER IV

### CRITERIA

This chapter relates closely to the previous one. Where the prior chapter defined ideals, this lists the specifics needed to create the body support. The section headings are the same, and follow the same order as the previous chapter (see Table 1).

### POSITIONS

The “thesis” chair should permit the user to sit, kneel, roll, and recline. In each of these positions or activities the body should be able to rock back and forth.

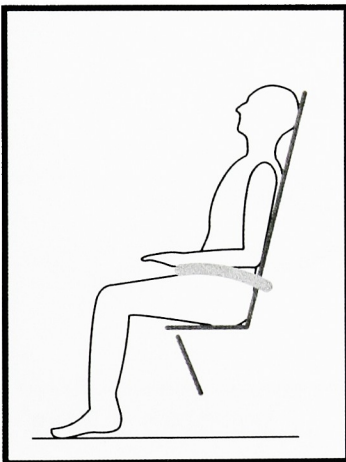

Figure 7. Upright

Hip and back support, in an upright position, should provide task seating (see Figure 7). The angles and sizes relate to the ergonomic recommendations listed earlier (see Figure 3).

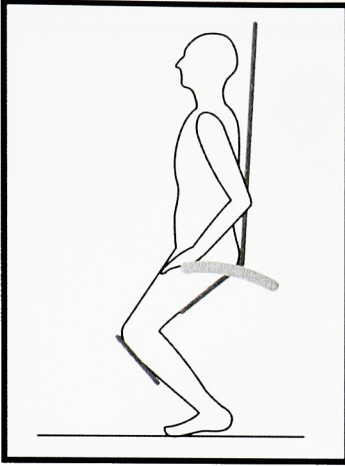

Figure 8. Kneeling

The chair, with knee and *ischial* support (see Figure 8), should create Balans-style seating. This kneeling position should be the largest angle of 135° from back to thigh (see Figure 2).

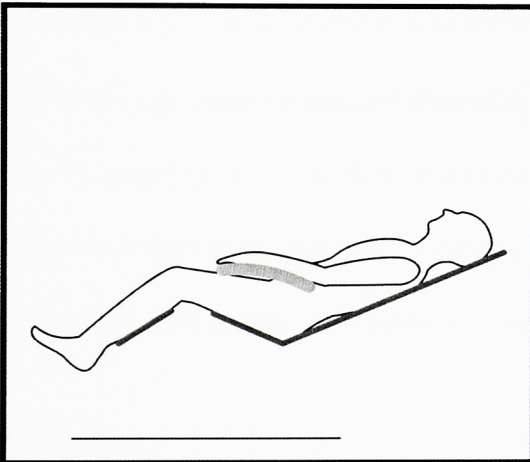

Figure 9. Reclining

The chair should promote relaxing by supporting the calf, hip, thigh, back and head. The chair, with back reclined and a dual purpose footrest/kneeling pad extended (see Figure 9) at the appropriate positions (see Figure 2), provides this support.

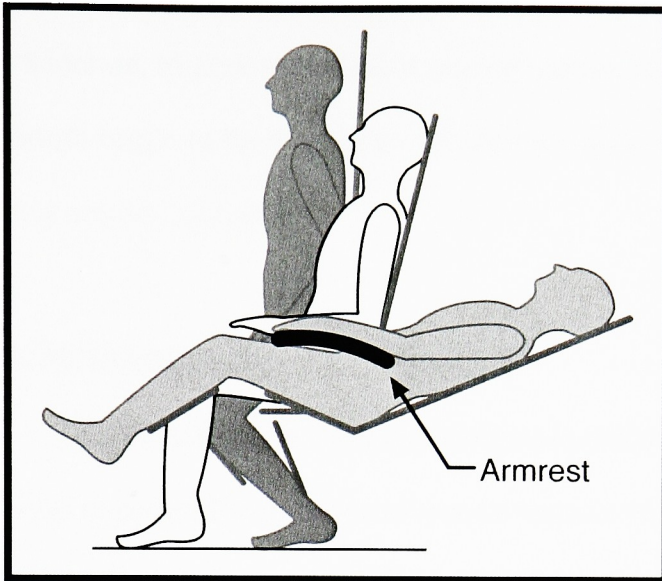

Figure 10. Fixed Armrest in All Three Positions

An armrest should be available in every position (see Figure 10). The placement is 7 to 10 inches above the upright seat position as noted in AT&T Bell Laboratories' recommended dimensions for VDT operators (see Figure 3).<sup>34</sup> The arms should be fixed at this height and not deviate from that point relative to the chair and floor to assist with rocking while reclined, provide a support for changing positions, and assist with getting in and out of the body support.

## SIZE

The footprint should be less than 24 inches wide, and the base must fit under most desks. The footrest/kneeling section should tuck under the seat when not in use to reduce the total space taken up by the body support.

Figure 3 shows recommended seat dimensions. In this case, the *seatpan*

---

34. Sanders, Mark S. *Human Factors in Engineering and Design*, 354.

height and seat length need to be at the lower end of the recommended sizes, at 15 inches, to accommodate a greater range of users. Similarly, the backrest length ought to be the higher recommendation, again to be usable by both larger and smaller people.

## **INTERFACE**

A passive and intuitive interface is preferred for user interaction with the body support. The number of moves required to change positions must be as few as possible. The user should be able to do all these operations without leaving the chair. For example, to change from a task seated position to a kneeling one should only involve positioning the knee pad unit and kneeling on it. Additionally, the back rest should lock to sit and unlock to recline. The seat must rotate forward and back as necessary to change from a seated position to a kneeling position. These operations should need little explanation to the user, and should relate semantically to the function, as is the case when lifting a part brings the unit up.

## **VISUAL**

The use of bright materials such as brushed aluminum, light wood, and a primary-colored seat fabric, can provide a playful aesthetic while the structure proper embodies a serious seating tool, not to be confused with an over-stuffed recliner. The use of organic, non-geometric, sweeping lines should provide visual movement. The Viennese sofa bed, with its visual cues to movement, mechanical function, and application of solid colors provides a guide (see Figure 6).



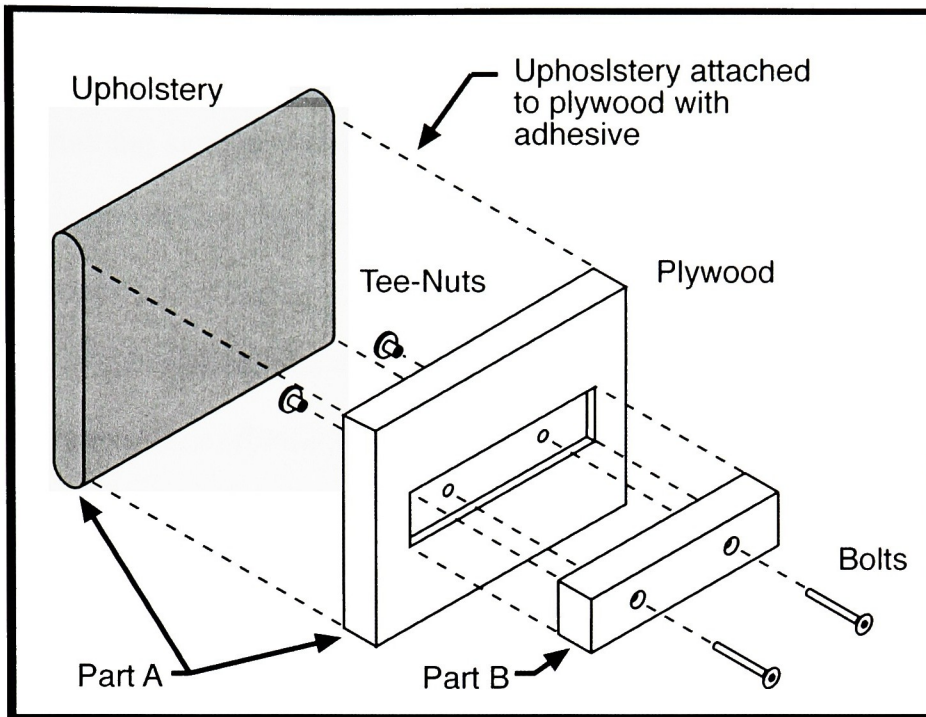

Figure 11. Exploded View of Padding and Knockdown Construction  
 A fabric and foam pad glued to a plywood structure make padded support part A. Part B is a structural member of the chair. Part A attaches to Part B with bolts and tee-nuts.

## CONSTRUCTION

Sections are built of individual parts which consist of aluminum, plywood, laminate, etc. and are fastened permanently either with glue, permanent mechanical fasteners, or both. In figure 11, Part A represents an upholstered section, such as a *seatpan*, backrest or knee pad, exploded into its constituent parts. Part B represents the structural frame that supports and attaches Part A to the other components of the chair.

Sections consist of major chair units, like the *seatpan* or the legrest/ kneeling pad, to reduce the number of parts and to create large manageable parts for minimal shipping bulk and ease of assembly by the end user.

Final assembly of sections into the completed chair is done by the end user, using knockdown hardware such as hexagon socket-head cap bolts, or something similar, and nuts installed within the sections during manufacturing. Figure 11 shows Part A being attached to Part B with two bolts, illustrating this concept.

Because of this modularity, end users can custom order parts to supplement or replace standard components for specific applications such as the scoliosis example stated earlier.

## **CHAPTER V**

### **DEVELOPMENT**

With goals set and criteria determined, design of the prototype began. This process naturally divided into mechanical, visual, and fabrication phases. The mechanical phase involved understanding, defining and designing the body support device. The visual concerned creating two-dimensional drawings of the shape and aesthetic of the chair. Fabrication completed the process with a final construction for presentation.

### **MECHANICAL**

The mechanical study included developing a physical solution. This addressed body position, chair mechanics, and the interaction between the body and the support device.

#### **Rocking and Kneeling Mechanics**

The first exploration investigated seat angles and body position of Balans seating. This encompassed going to local furniture stores and measuring currently manufactured products for kneeling body support.

Concurrently, quarter-size models of different types of rocking chairs were made to better understand and recreate the motions involved. These models included a glider (Canadian rocker), a Shaker style rocker, and single pivot seat found in the most popular of swivel chairs. The results indicated the Shaker rocker had the greatest range of motion and provided the proper angle for a kneeling

position at the apex of the forward rocking motion.

The next course of development started with a suggestion made during a presentation to the thesis committee. The idea was not to design a whole new chair, but to create a tilt mechanism to add to existing chairs. With the challenge of designing a tilt mechanism, an understanding was needed of the actual seat motion during rocking.

### Rocking Motion and Path

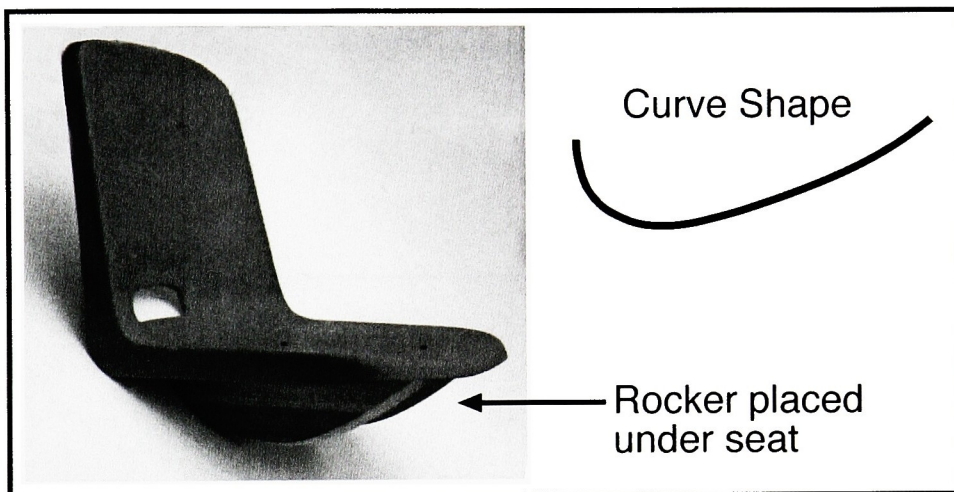

Figure 12. Seat with Rocker

The first attempt at duplicating the rocking motion was to make a small curve close to the underside of the seat. This was done intuitively by drawing and cutting the curve that would approximate the motion of the seat (see Figure 12). The rocker attached to the seat failed to create a smooth motion on a flat surface.

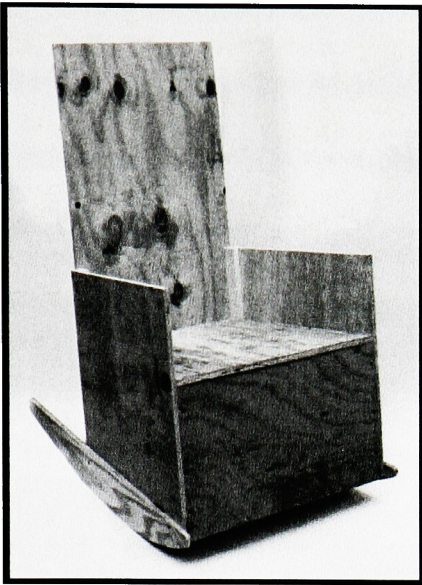

Figure 13. Full-size Plywood "Shaker" Rocker

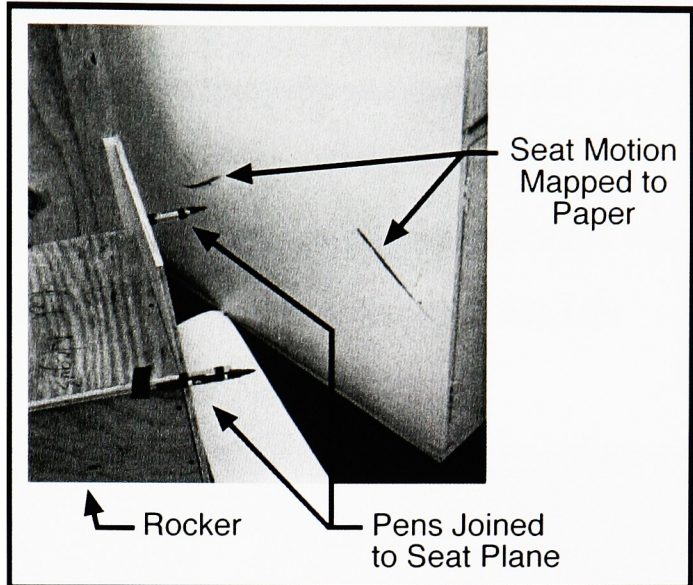

Figure 14. Seat Motion Mapped to Paper

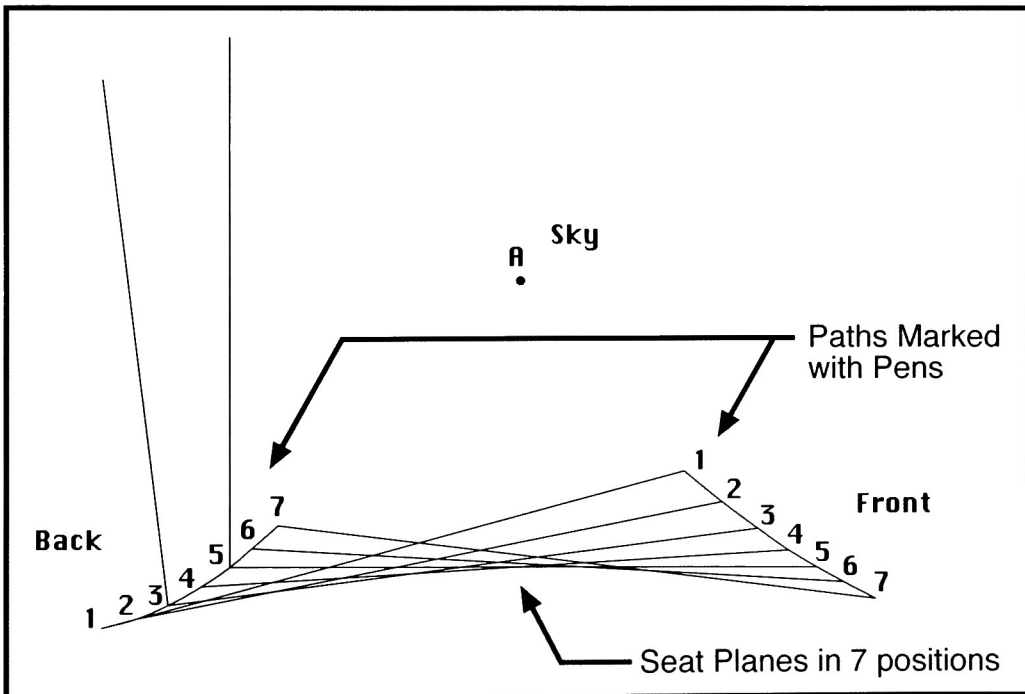

Figure 15. Computer-Aided Design Rocking Seat Motion Map

A more empirical method of understanding the movement was necessary. Before the second attempt, a full-size plywood mock-up was made to the dimensions of a Shaker rocker (see Figure 13). The path of the seat plane's motion was drawn on paper (see Figure 14), measured, and entered into MicroStation, a computer-aided design (CAD) program (see Figure 15). This defined the path the seat would follow.

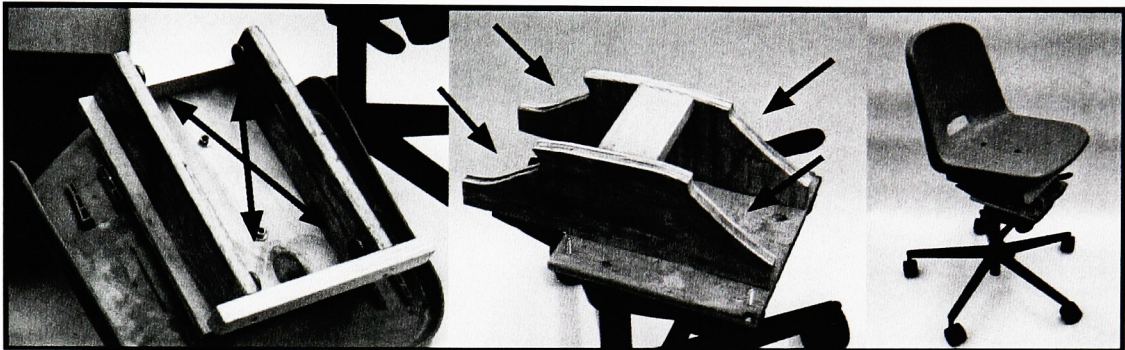

Figure 16. Track and Rail Mechanism

*Left*, arrows point to wheels attached to seat; *center*, arrows point to the rail curves the wheels move upon; *right*, complete unit.

Using CAD, the curves through which the seat moved while rocking were reduced in scale so they could be placed under the seat and become tracks upon which a test chair would ride (see the center image of Figure 16). A matching plywood trolley with wheels was attached to the seat (see the left image of Figure 16). Working together, these restricted the seat motion to the shape of the track, so the seat successfully followed the same motion as the plywood mock-up. However, during a demonstration for the thesis chairman this mechanism failed, toppling me over backwards. A high center of gravity moving a large distance over a single support point made of rails and rollers caused this failure. Additionally, the rocking and rolling actions working together made it difficult to control.

## Body Positions

This direction was tabled with the failure described on page 29. A better understanding of the body in relation to the support device was needed and, using the thesis committee chairman's advice, a finite definition of an anthropometric seat and body position was created.

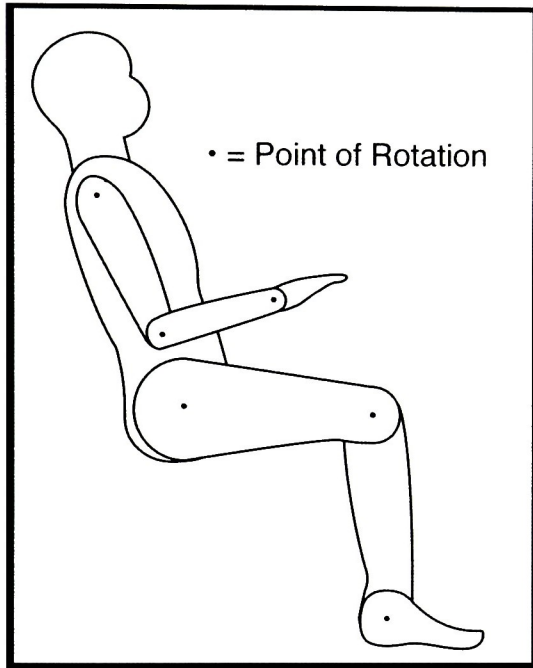

Figure 17. Anthropometric Figure

An anthropometric figure of a 5th occidental percentile male was made with paper, pivoted at the points indicated in Figure 17.<sup>35</sup> Using the paper model became problematic because, although the model could be put in the seated, kneeling, and reclining positions, it was difficult to visualize where the body parts would be when moving between positions and when rocking. The two-dimensional

---

35. Henry Dreyfuss Associates, *The Measure of Man and Women: Human Factors in Design* (New York: Whitney Library of Design, 1993), 23.

experiment was converted to a computer animation of positions with body movement (see Appendix). Alias/Wavefront Power Animator assisted in creation of the animation. The animation helped illustrate and provide a finite measurement and motion path for the seat supports, but did not help with creating a mechanical solution.

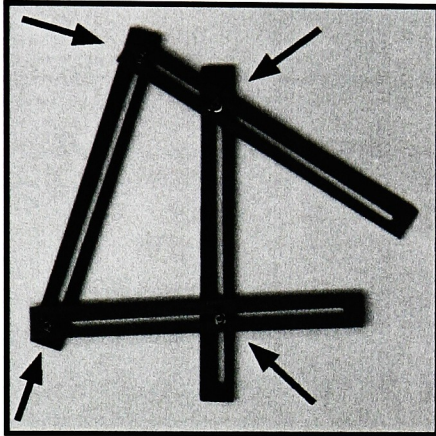

Figure 18. Four-Bar Mechanism  
Each bar independently pivots and slides at arrows.

### **Mechanical Engineering Advice**

With the need for more assistance, I was referred by thesis committee member Kim Sherman to Kevin Kockersberger, Professor of Mechanical Engineering at Rochester Institute of Technology. Analyzing the animation converted to two-dimensional illustrations, he recommended experimenting with a four-bar mechanism (see Figure 18).



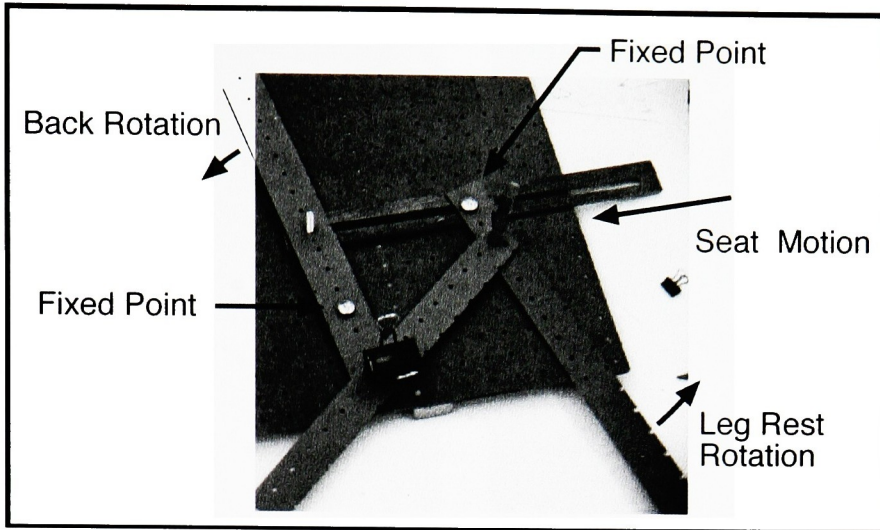

Figure 19. Four-Bar Solution

With experimentation, a few solutions were developed. The best (see Figure 19) worked well for the desired reclining, kneeling, and upright body configuration, but it did not rock. It also presented an issue of the leg rest/knee pad having to pass through the leg when changing positions.

The four-bar mechanism and solution was demonstrated to the advisors. Several solutions were considered and judged impractical. Working from a full-size mechanism such as a profiler was determined as the next step. A profiler is a device to assist with creating a chair profile with angles and positions.

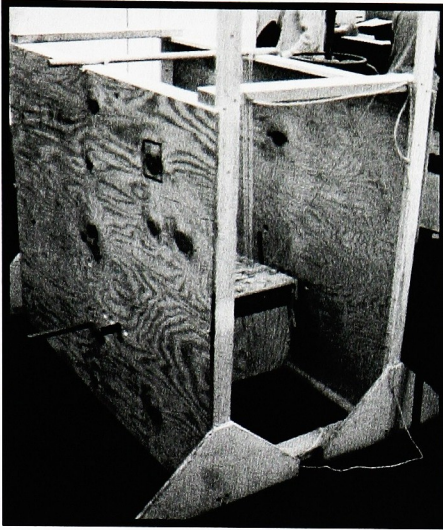

Figure 20. Profiler

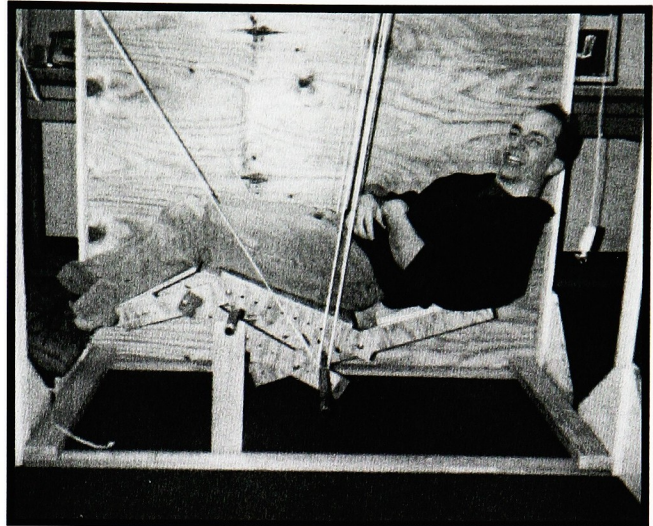

Figure 21. Profiler Combined with Four-Bar Solution in Reclined Position (One side of the profiler has been removed for photo)

## Profiler

A profiler was built (see Figure 20) to hold a seat with the dimensions as shown in Figure 3. The angles for the relaxed and kneeling positions were determined using the angles shown in Figure 2 as guidelines. The four-bar mechanism was combined with the profiler (see Figure 21). This produced a partial solution, but a full solution needed resolutions for the transition from sitting to kneeling, for rocking and for rolling.

## Position Transition Difficulties

### Kneeling Issues

The four-bar mechanism made the lower legs captive when kneeling, making the shift from kneeling to sitting awkward. Users would have to get off the seat, change the position, and carefully sit again, placing their legs in the hole created between the two outside four-bar mechanisms and kneeling pad. This action didn't meet the passive movement criteria. Many sketches and ideas

centered on including rotating pads and redesigning the mechanism, but none fit the set standards.

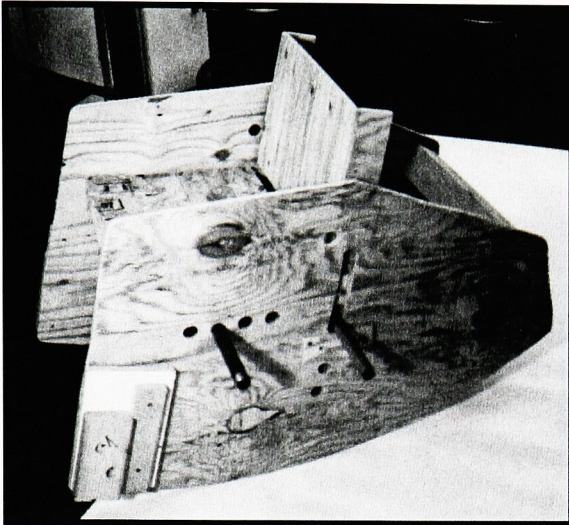

Figure 22. Four-Bar Solution First Working Design

### **Rocking**

The primary focus returned to rocking with kneeling still unresolved. By adding a stretcher and removing unneeded material to fabricate rocker runners, the profiler became the first completed, working design without rolling (see Figure 22). This was presented to peers and faculty with other demonstrations of the intended body placement and motions.

### **Rolling**

The chief advisor, Craig McArt, suggested a wheeled cradle to house the mechanism. This would allow the chair to roll and rock while maintaining fixed arms. A full-size cradle mock-up was built; it worked successfully.

### Resolving Kneeling Issues

At this point, kneeling again became the primary focus. More sketches and ideas were developed with poor results. A review of criteria helped provide ideas. The most promising of these involved a kneeling pad/legrest that was independent of the four-bar mechanism, to be attached to and extend out from the bottom of the chair through a pin and groove mechanism similar to the sofa bed in Figure 4.

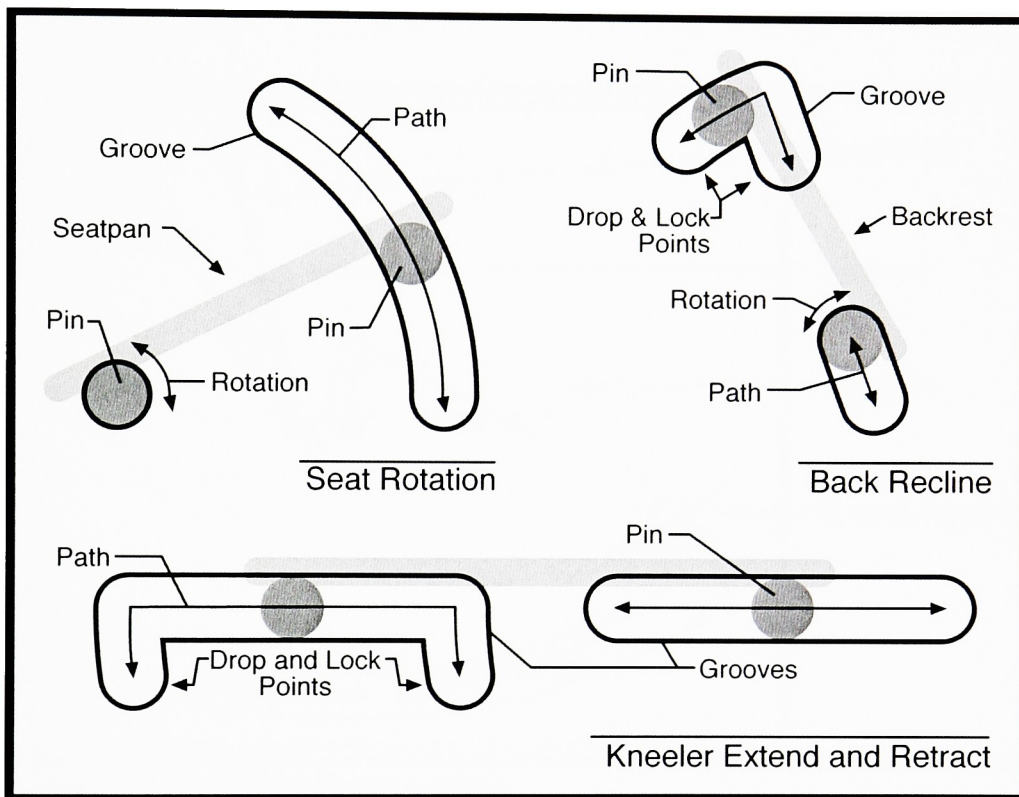

Figure 23. Seat, Back and Kneeler/Leg-rest Pin and Groove Paths

This led to a redesign of the back and seat mechanisms, bringing the design more in line with the original criteria. The four-bar solution was changed, keeping the idea of the pivot points, to three similar independent mechanisms for the back, the seat, and the leg/knee support (see Figure 23). A mock-up was changed to test the new concept.

### Conversion from CAD to Aesthetic

The new, completely working, prototype was measured and modeled in CAD. The mechanisms were refined and simplified with the computer. Scale plots were made of the mechanisms and used for the next phase, that of aesthetic development.

### VISUALIZATION

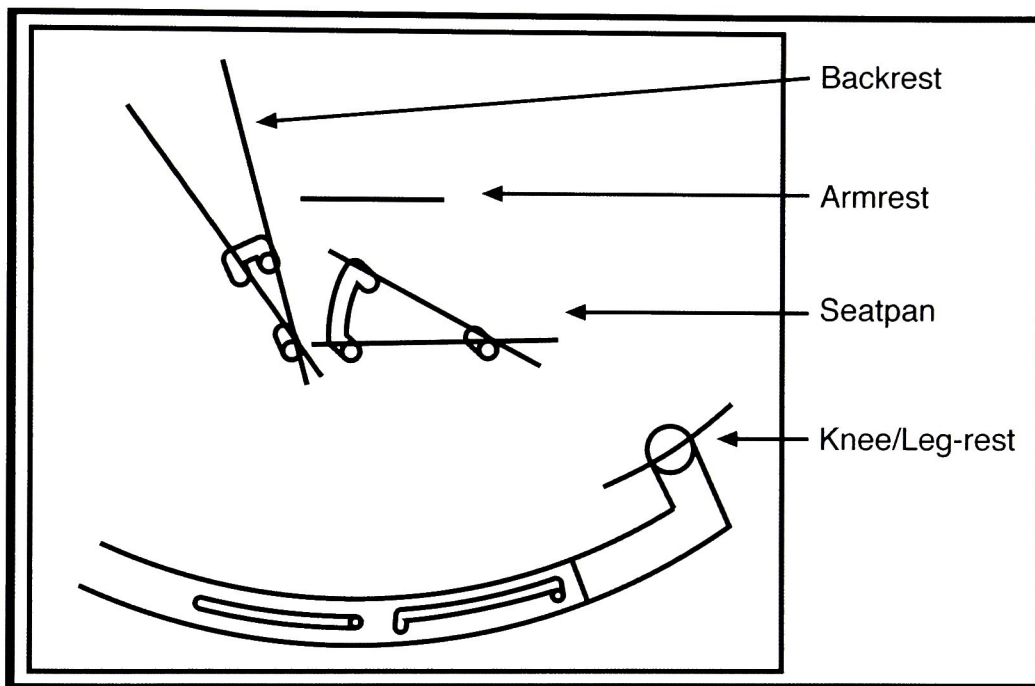

Figure 24. Side View of Mechanisms

Plots of the mechanisms were used as a basis for drawing side views of the body support components (Figure 24). After several drawings, the preferred contour was scanned into the computer, added to the current CAD file and refined to the final appearance. The aesthetic goals and criteria set in Chapters II and III were used to complete the design and determine colors.

## FABRICATION

Construction of the prototype required finding materials, making cut plans, cutting and assembling the parts. These processes occurred continuously and simultaneously up to completion.

### Material

The material choices were based primarily on aesthetics. Several elements were sampled and tested for strength and durability. The final selections were aluminum for the mechanical pieces, a Baltic birch sheet plywood for the actual structure, tapered hexagonal head bolts with embedded Tee-nuts and socket head cap screws for fastening, and Formica laminate as a bright durable outer coating. Collecting the materials involved finding suppliers, ordering and purchasing. The availability of supplies influenced the schedule of work.

### Cutting and Construction

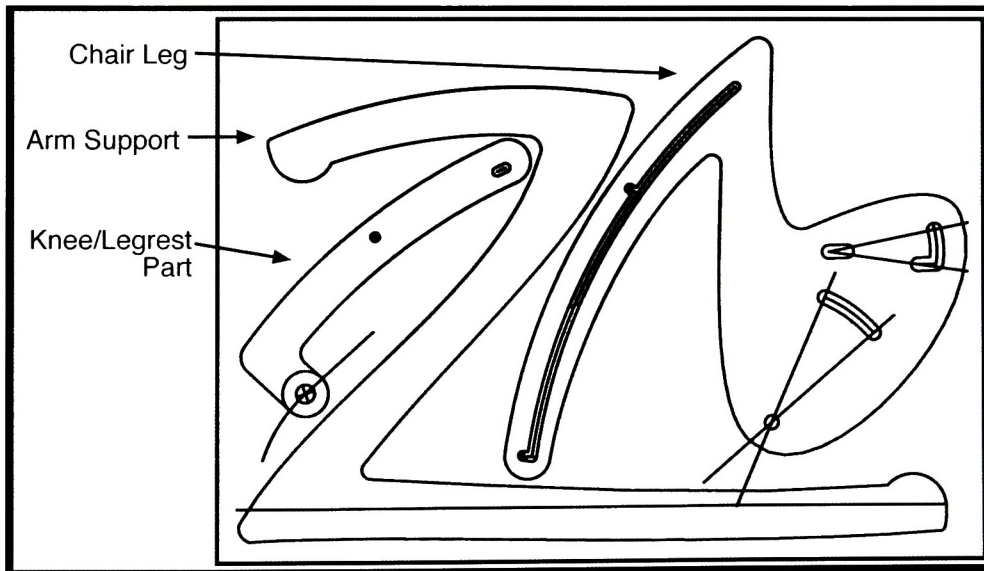

Figure 25. Plywood Parts Cut Pattern

Parallel to this, the computer models were arranged into two-dimensional patterns for chair parts and plotted full-size on paper (see Figure 25). This paper was attached to Masonite and used to create templates for a router.

The plywood was laminated together and the templates were attached. Using the guiding templates, the plywood was cut by a router. Then the Formica was attached to the chair parts and trimmed, again with a router.

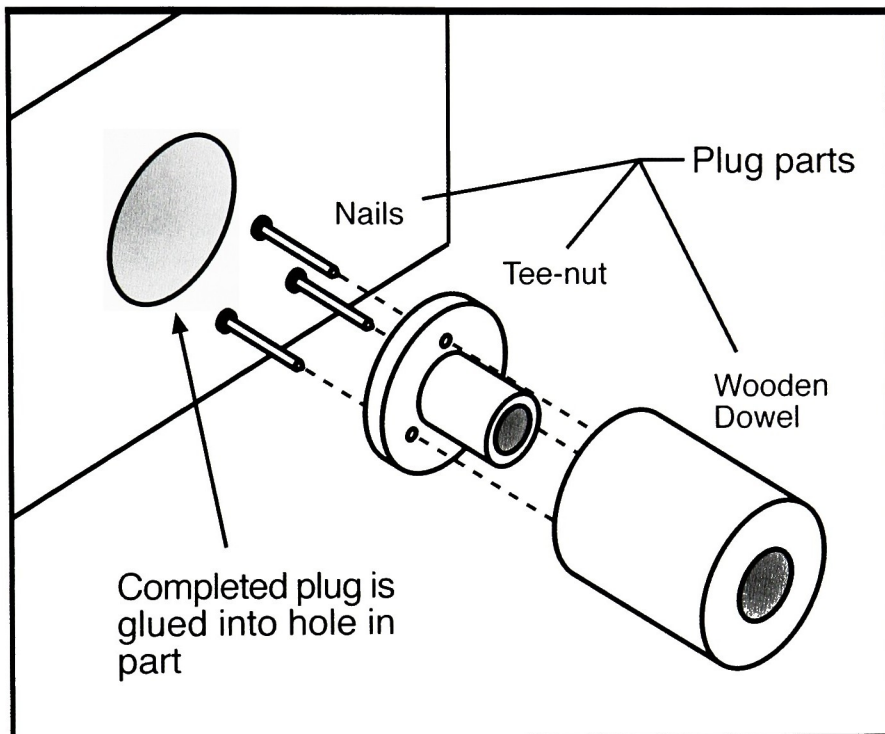

Figure 26. Tee-nut Plug Assemblage

The next step involved making Tee-nut plugs for fastening knockdown bolts. These consisted of a Tee-nut glued and nailed into hollowed dowel (see Figure 26). Holes were drilled in the stretcher, carriage, arms, and leg-body supports for the plugs and bolts. The plugs were inserted and glued. Casters were added to the carriage section as well. With this completed and the glue dry, the parts were

assembled and measurements were taken to make the mechanical pieces.

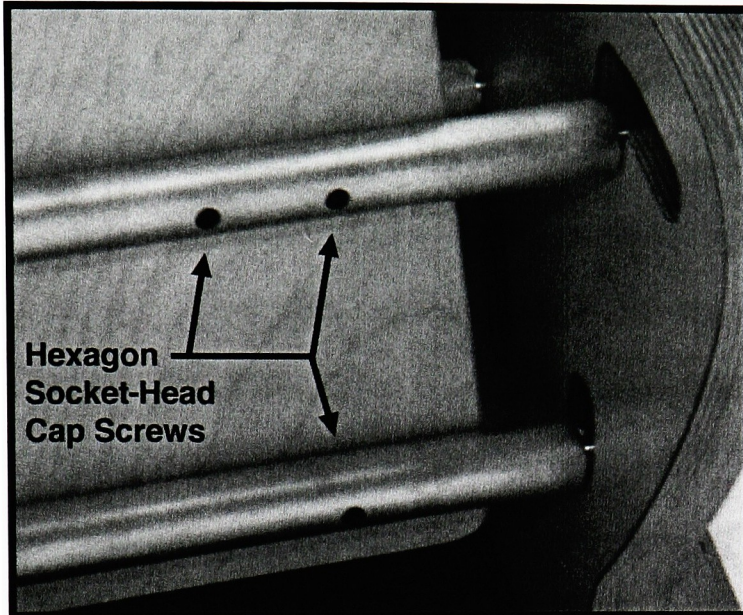

Figure 27. Back Rest Mechanics and Fasteners

Hexagon Socket-Head Cap Screws are countersunk and fasten the back to the rods which support the plywood backrest. At the right are the grooves in which the rods move to recline the backrest.

The aluminum rod was cut using a milling machine and metal lathe. These rods were then added to the prototype and used to lay out the plywood upholstery supports. The rods and plywood were drilled and fastened with socket-head cap screws (see Figure 27) and Tee-nuts as in Figure 11.

The exposed wood, other than where the upholstery would be affixed, was sanded and sealed. Using the plywood section of the *seatpan*, knee/leg pad, and backrest, the cushion fabric was cut to size. The fabric was sewn together and stuffed with upholstery foam. Hand stitching finished the cushion, which was then glued into place to complete the building of these parts.



## Assembling

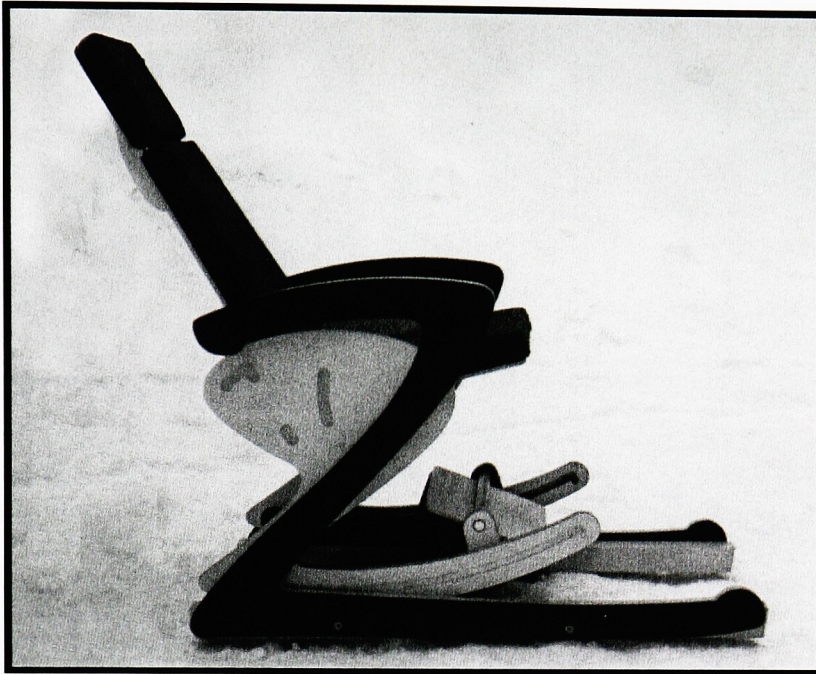

Figure 28. Thesis Chair Assembled in Task Position

With the completion of the parts, the chair was assembled and tested (see Figure 28). It worked except for some slippage where the rocker leg contacted the carriage. This problem was solved by creating index pins, (see Figure 29) as suggested by committee member Doug Cleminshaw.

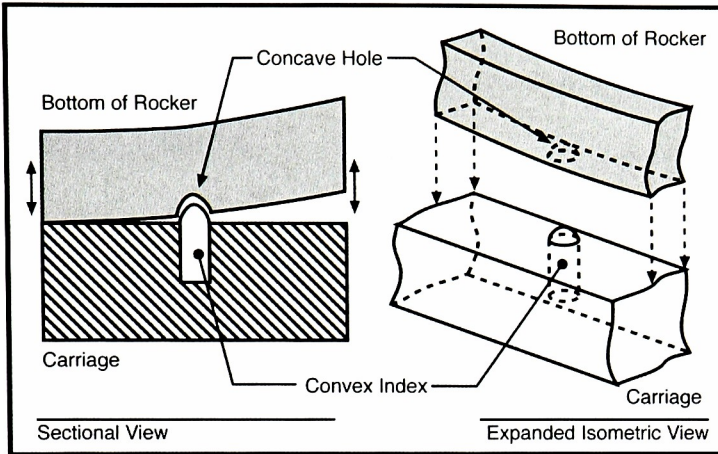

Figure 29. Rocking Index

The female concave hole in the bottom of the rocker moves over the male convex index pin in the carriage section, much like one link in a bicycle chain moving over its gear. This stops the rocker from sliding or changing position.

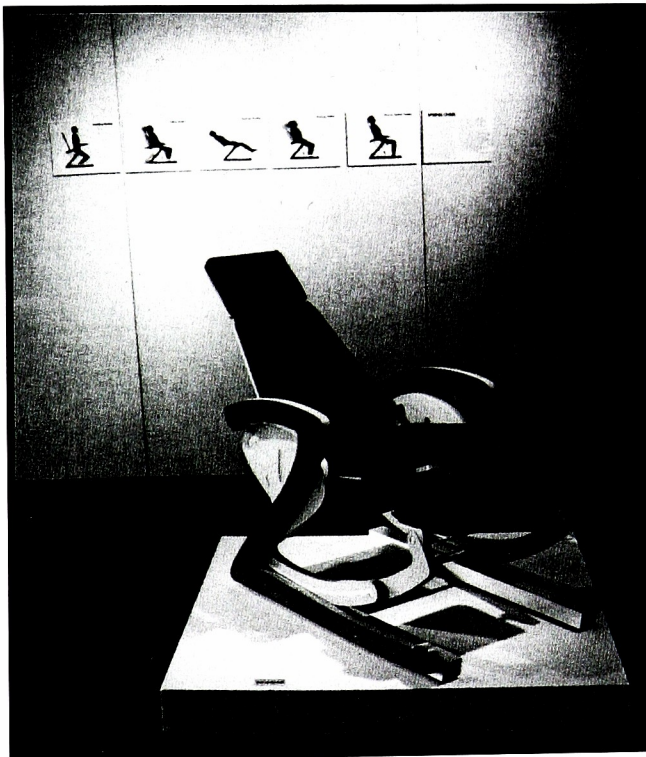

Figure 30. Chair in Show

Displayed with explanations of positions and movement in the background.

The final prototype was displayed in the Rochester Institute of Technology Bevier Gallery for the 1997 Thesis Show (see Figure 30).

## CHAPTER VI

### CONCLUSION



Figure 31. Finished Prototype

*Left*, 3/4 view of task seat position; *upper right*, side view of kneeler position; *lower right*, side view of reclined position.

### SUMMARY

There are health risks associated with prolonged sitting. These risks range from poor blood circulation, muscle fatigue, and lifestyle inhibiting back pain to a higher risk for herniated discs in the spine. A primary cause is static body support, which occurs in the workplace. This affects everyone by increasing costs for health care and increasing risk of injury for many of us.

The prototype (see Figure 31) developed here is a solution. First, it uses

the recommendations set forth by human factors specialists. These include prescribed seat dimensions and multiple body positions. Second, the thesis chair, through rocking, eliminates stagnation, which is a primary cause of all the problems listed.

## **CRITIQUE**

Even though the design of the thesis chair has fulfilled the goals set in Chapter 2, it needs more study to resolve some unforeseen safety hazards, to develop better mechanisms, and to measure its effectiveness for enhancing health. Most of these matters were noted during a thesis committee critique at the exhibit.

### **Safety**

Some unanticipated safety matters give rise to possible bodily injury. The extremities are most likely to be endangered. For instance, a shearing action between the arm rests/supports and chair legs occurs when rocking. The open grooves for pivoting the seatpan and the backrest can pinch or crush fingers.

Two less hazardous issues concern a weakness resulting in a left-to-right motion in the arms and a potential with the inner body support for rocking over backwards. These predicaments can be fixed with the addition of a cross piece placed behind the seat and between the arms.

### **Further development**

More development is recommended to explore improvements for the thesis chair. One need is to explore a rolling system that includes the ability to lock in

place. Research into different materials to reduce size and weight is advised. Some empirical testing would be useful in determining the level of health improvement this prototype provides.

## **FINAL REMARKS**

This thesis defines the problem with stagnant seating and provides a design solution to alleviate harm. The prototype illustrates that solution. With some further study and modification, this chair would provide a design reference and usable product for seating improvement.

# APPENDIX

## BIBLIOGRAPHY

- "Adjustability's Untapped Potential." *Workplace Ergonomics* May/June (1996):11.
- "American Ergonomics: Press Info," [WWW page]; available from <http://www.americanergonomics.com/press/ergomax.sit>; Internet; accessed Fri, 29 Sep 2000.
- "Back to Comfort," [WWW page]; available from <http://www.redbank.com/backtocomfort/products.html>; Internet; accessed Fri, 27 Mar 1998.
- Berg, Joseph A. *Posture and the Sedentary Man*. San Francisco, CA: A.C.C.O. Convention, 18-19 May 1968.
- Bridger, Robert S. "Postural Adaptations to a Sloping Chair and Work Surface." *Human Factors* vol.30 (April 1988): 237-47.
- Bridget, Johnson, and Howard Singerman, ed. *Architectural Sculpture*. Los Angeles Institute of Contemporary Art, 1980.
- "Brigger Flip-Flop Recliner," [WWW page]; available from <http://www.backbenimble.com/brigflip.htm>; Internet; accessed 27 March 1998.
- Butterfield, Jan. *The Art of Light and Space*. New York: Abbeville Press, 1993.
- Clark, Thomas Stephen. *The Ergonomics of Workspaces and Machines: A Design Manual*. London, Philadelphia: Taylor & Francis, 1984.
- Colpitt, Francis. *Minimal Art: The Critical Perspective*. Ann Arbor, Michigan: UMI Research Press, 1990.
- "Creative Supports," [WWW page]; available from <http://www.creativesupports.com/seating.html>; Internet; accessed Fri, 27 March 1998.
- Davies, Stephen. "The Simple Science of Seating." *Technology Review* vol. 95 (Aug./Sept. 1992): p34-40.
- "Ergonomic Specialties" [WWW page]; available from [http://www.ergospec.com/off\\_sea.html](http://www.ergospec.com/off_sea.html); Internet; accessed Friday, 27 March 1998.
- Ergonomics: Low-Back Pain, Carpal Tunnel Syndrome, and Upper Extremity Disorders in the Workplace*. Philadelphia: Hanley & Belfus, Inc. 1992.
- Favata, Ignazia. *Joe Colombo and Italian Design of the Sixties*. Cambridge, Massachusetts: MIT Press, 1988.

- Foster, Hal, ed. *Vision and Visuality*. Seattle: Berg Press, 1990.
- Graham, Clare. *Ceremonial and Commemorative Chairs in Great Britain*. London: Victoria & Albert Museum, 1994.
- Gricco, A. "Sitting Posture: An Old Problem and a New One." *Ergonomics* 29 (1986):345-362
- "Hag Balans," [WWW page]; available from <http://www.backbenimble.com/hagbalan.htm>; Internet; accessed Fri, 27 March 1998.
- Hale, Nathan Cabot. *Abstraction in Art and Nature*. New York: Watson-Guption Publications, 1972.
- Henry Dreyfuss Associates. *The Measure of Man and Women: Human Factors in Design*. New York: Whitney Library of Design, 1993.
- Hockenberry, Jack. *A Systems Approach to Long Term Task Seating Design*. Owatonna, Minnesota: by the author, 1981.
- "JDI Group Ergonomic Workstation Chair," [WWW page]; available from <http://www.awa.com/jdi/index.html>; Internet, accessed Friday, 27 March 98.
- Johnson, Peter. *The Phillips Guide to Chairs*. London: Merehurst Press; New York, NY: Riverside Book Co.
- Kelsey, J.L. "An Epidemiological Study of Acute Herniated Lumbar Intervertebral Discs." *Rheum Rehab* v14 (1975): 144.
- Khatchadourian, Haig. *The Concept of Art*. New York: New York University Press, 1971.
- Knobel, Lance. *Office Furniture*. New York: E.P. Dutton, 1987.
- Knox, Richard A. "Rock of Aged: Chair's Sway May Soothe Ailing Elders." *Boston Sunday Globe* April 26 (1998):A1, A24.
- Krischanitz, Adolf. "One-Shaped Couch." Furniture. As reproduced in *Wien Möbel* (Vienna Furniture). Vienna: Die Secession, 1989.
- Die Sprache der Kunst*. Translated by Eleonora Louis, Christian Theo Steiner, and Toni Stoos. Stuttgart: Dr. Cantz'sche Press, 1993.
- Metzger, Edward A. "The Importance of Lumbar Support." *Workplace Ergonomics* July/August (1996):14–16.



- Moser, Thomas. *How to Build Shaker Furniture*. New York: Drake, 1977.
- Neil, Andrew. "The Value of Dynamic Movement." *Workplace Ergonomics* July/August (1996):17-19.
- Null, Roberta L. *Universal Design: Creative Solutions for ADA Compliance*. Belmont, California: Professional Publications, 1996.
- Occupational Low Back Pain: Assessment, Treatment, and Prevention*. St. Louis: Mosby Year Book, 1991.
- Panero, Julius and Martin Zelnik. *Human Dimensions and Interior Space*. New York: Billboard Publications, 1979.
- Pikna, Janice Kuiper. "The Acute Circulatory Responses of Elderly Women To Upper and/or Lower Extremity Exercise In a Specially Designed Rocking Chair." MS in Nursing, University of Wisconsin, Milwaukee, December 1986.
- Romer, Mike. *Rud Thygesen, Johnny Sorensen: 9006 Dage med Design*. Kobenhavn: Nyt Nordisk Forlag A. Busck, 1991.
- "Sam Clar Office Furniture," [WWW page]; available from <http://www.samclar.com/chair.html>; Internet; accessed Friday, 27 March 1998.
- Sanders, Mark S. and Ernest J. McCormick. *Human Factors in Engineering and Design*. New York: McGraw-Hill, 1987.
- Schmidt, Georg and Robert Schenk ed. *Kunst und Naturform*. Basel, Basilius Press AG, 1960.
- Sears, Barry. *The Zone*. New York, New York: Regan Books/HarperCollins, 1997.
- Serber, Hector. *Ergomax CB and ISOPS: A New Paradigm for the Biomechanics of Ergonomic Seating*. (a pamphlet from American Ergonomics Corporation, Novato, CA).
- Steinbaum, Bernice. *The Rocker: An American Design Tradition*. New York: Rizzoli, 1992.
- Stewart, Doug. "Modern Designers Still Can't Make the Perfect Chair." *Smithsonian* v17 (April 1986):96-102.
- Taylor, Frederick Winslow, *The Principles of Scientific Management*. New York: Harper, 1947. Reprint, New York: Norton, 1967.

Taylor, Frederick Winslow. *Scientific Management, Comprising Shop Management, The Principles of Scientific Management [and] Testimony Before the Special House Committee*. With a foreword by Harlow S. Person. New York: Harper, 1947

Taylor, Mark: "In Search of an Ideal Seated Posture." *Workplace Ergonomics* July/August (1996):11-13.

Wanning, Esther. "Heal Your Aching Back." edited by Michael Castleman. *The Mother Earth News* vol.93 May/June (1985):126-8.

*Wear It in Good Health The Aeron™ Chair by Herman Miller*. Zeeland, MI USA, 1994.